



**TILT-A-WAY
MODEL PSB M30B
& PSB M40 B
HYDRAULIC VERTICAL PIVOT
GATE**

**Operator's & Parts
Manual**



**NOTE: WHEN ORDERING PARTS, PLEASE HAVE YOUR SERIAL NUMBER
TO ENSURE THE CORRECT PARTS ARE SENT TO YOU.**

**Ideal Manufacturing, Inc. • 2011 Harnish Blvd. • Billings, MT 59101
P (406) 656-4360 • F (406) 656-4363**

This manual is subject to change without notices.

TABLE OF CONTENTS

DESCRIPTION	PAGE NO.
WARRANTY	BEGINNING
SAFETY INFORMATION	PAGE 1
CLASS OF VEHICULAR GATES	PAGE 1
PROTECTION AGAINST ENTRAPMENT	PAGE 1
GATE SPECIFICATIONS	PAGE 2
ALTERNATE FENCE SCHEMES	PAGE 3
GENERAL INFORMATION	PAGE 4
GENERAL CIRCUIT BOARD CONNECTIONS	PAGE 4
LOGIC TIMER BOARD GENERAL CAPABILITY	PAGES 4, 5
208 / 240 ELECTRICAL DIAGRAM	PAGES 6, 7
OPERATOR FIELD INSTALLATION FOR ASSEMBLED GATE	PAGES 8, 9
OPERATOR FIELD INSTALLATION FOR UNASSEMBLED GATE	PAGES 8, 9
BALANCE SYSTEM ADJUSTMENT AND SAFETY WARRINGS	PAGES 10, 11
GENERAL MAINTENANCE	PAGE 12
GENERAL ARRANGEMENT	PAGES 12, 13
BARRIER CARRIAGE	PAGES 14, 15
ACTUATOR CYLINDER WITH COMPONENTS	PAGES 16, 17
BARRIER UNIT	PAGE 18
BALANCE SYSTEM 6 CABLE & SHEAVE	PAGE 19
BALANCE SYSTEM CABLE GUIDE	PAGE 20
ACCESS GUARDS	PAGE 21
BALANCE SYSTEM SPRING TENSIONER UNIT	PAGES 22, 23
EXTENDED HYDRAULIC SYSTEM	PAGES 24, 25
WEATHER GUARD OVERHEAD PROTECTION	PAGE 26
COLD WEATHER PACKAGE	PAGE 27
4 GALLON POWER UNIT	PAGES 28, 29
ELECTRICAL EMERGENCY STOP	PAGE 30
SAFETY WARNING LIGHT	PAGE 31
MANUAL KEY SWITCH	PAGE 32
OPERATOR ENCLOSURE COVERS & OPTIONAL SNOW DOORS	PAGE 33
ELECTRICAL LOGIC TIMER BOARD	PAGE 34
ELECTROMAGNETIC LOCK	PAGE 35
REMOTE CONTROL STATION	PAGE 36
ELECTRICAL LOOP WIRING	PAGE 37
LOOP DETECTOR DIAGRAM	PAGE 38
LOOP WIRES INSTALLATION	PAGES 38-1 THRU 38-10
LOOP WIRES TROUBLE SHOOTING	PAGES 38-11 THRU 38-12
PHOTO EYE LOCATION	PAGE 39
REFLECTIVE TYPE PHOTO EYE	PAGE 40
GATE OPEN INDICATOR	PAGE 41
REVERSING EDGE INSTALLATION	PAGE 42
RADIO RECEIVER MANUAL	PAGES 43 THRU 50
RADIO RECEIVER DIAGRAM THREE BUTTON	PAGE 51
RADIO RECEIVER DIAGRAM SINGLE BUTTON	PAGE 52
TROUBLE SHOOTING GUIDE	PAGE 53



2011 Harnish Blvd.
Billings, MT 59101

Phone: (406)656-4360/(800)523-3888
Fax: (406)656-4363

TILT-A-WAY LIMITED WARRANTY

Ideal Manufacturing warrants that its Tilt-A-Way vertical pivot gate Model PSB M30B product will be free from defects in materials and workmanship for a period of 3 years from the date of purchase. If the product fails to function because of defects in materials or workmanship within the 3 year period of time being used for the purpose for which it was designed, Ideal Manufacturing will repair or replace the defective part at its option. This warranty excludes electrical components and damage due to Acts of God, unauthorized modifications, misuse, abuse or negligence to this product. This warranty does not cover products or accessories that are not manufactured by Ideal Manufacturing, Inc. That product follows the warranty, and guidelines of that manufacturer.

In order to proceed with a warranty claim, Ideal Manufacturing must be notified of the problem. A new part will be shipped out prepaid (Ground UPS). If the customer requests that the part be expedited that shipping charge will be charged to the owner.

The part that is being warranted must be returned to Ideal Manufacturing, postage prepaid. When the new part is shipped out, it will go out with an invoice and a warranty part return number. The defective part must be returned to Ideal Manufacturing, freight prepaid, with the warranty part return number. At that time the invoice will be considered paid in full.

This warranty is exclusive and in lieu of all other obligation, liabilities or warranties. In no event shall Ideal Manufacturing be liable or responsible for incidental or consequential damage or for any other direct or indirect damage loss, cost, expense or fee.

This warranty shall not apply to any products or parts that have been altered or repaired without written consent of Ideal Manufacturing.

Labor to remove and reinstall defective product or parts will be paid from a labor rate and schedule only. Consult Ideal Manufacturing for that rate and schedule.

For further information on returning your product or questions concerning Ideal Manufacturing warranty, please contact Ideal Manufacturing.

IMPORTANT SAFETY INFORMATION

Before installing the installer should read and understand the owners manual and safety instructions. The owner should read, and keep this owners manual. Read and Follow All Instructions.

WARNING-TO REDUCE THE RISK OF INJURY OR DEATH TO PERSONS

1. Do not operate gate unless all safety devices are connected and working properly.
2. Do not permit children to play on or around a gate. Keep all controls out of reach from children.
3. Automatic gates are not intended for pedestrian use. Pedestrians must be supplied a separate entrance separate from the automatic gate.
4. Never operate an automatic gate system without visual contact so it can be shut down if necessary.
5. Access controls, are required, to be mounted at least 6 feet away from the gate and operator.
6. Disconnect all power before performing any maintenance on your gate or operator.
7. Keep your gate properly maintained-have a qualified service person make all repairs.
8. A qualified technician should test your gate monthly. The gate MUST reverse on contact with a rigid object or stop when an object activates a non-contact sensor. After adjusting the force of the limit of travel, retest the gate operator. Failure to adjust and retest the gate operator properly can increase the risk of injury or death.
9. The gate and operator must have two appropriate safety devices to match the gate class installation.
10. Operator and barrier must display warning signs on both sides, in view of operator.
11. Do not install added weight to the gate barrier, your barrier has been balanced at the factory, if you add weight to the gate barrier it will make your gate out of balance, which could cause it to malfunction.
12. Only qualified personnel should install this equipment. Failure to meet this requirement could cause severe injury and or death, for which the manufacturer cannot be held responsible.
13. Safety devices, such as photo eyes and reversing edges should be installed to provide protection for personal property and pedestrians.
14. Before turning the power on make sure that the correct voltage has been supplied to the electric motor and the equipment has been properly grounded.
15. Always keep people and objects away from the gate. **NO ONE SHOULD CROSS THE PATH OF THE MOVING GATE.**

CLASS OF VEHICULAR GATES

Glossary

CLASS I-RESIDENTIAL VEHICULAR GATE OPERATOR (3.19)

A vehicular gate operator (or system) intended for use in garages or parking areas associated with a residence of one to four single families.

CLASS II-COMMERCIAL/GENERAL ACCESS VEHICULAR GATE OPERATOR (3.4)

A vehicular gate operator (or system) intended for use in a commercial location or building such as multi-family housing unit (five or more single family unit), hotel, garages, retail store, or other buildings accessible by of servicing the general public.

CLASS III-INDUSTRIAL/LIMITED ACCESS VEHICULAR GATE OPERATOR (3.11)

A vehicular gate operator (or system) intended for use in an industrial location or building such as a factory or loading dock area or other locations not accessible by or intended to service the general public.

CLASS IV-RESTRICTED ACCESS VEHICULAR GATE OPERATOR (3.20)

A vehicular gate operator (or system) intended for use in a guarded industrial location or building such as an airport security area or other restricted access locations not servicing the general public, in which unauthorized access is prevented via supervision by security personal.

INSTRUCTIONS FOR MANUAL OPERATION TILT-A-WAY MODEL PSB M30B

Note: Use the manual operation only when the gate is not moving and with the power turned off

1. *Locate two Brass colored knurled knobs on the top of the pump housing*
2. *(If equipped with a cold weather package, lift flap on the black cover to access knobs.)*
3. *Turn both knobs counter clockwise one full turn to open.*
4. *Gate barrier can now be lifted manually from out at the end of gate.*
5. *Turn knobs clockwise to close, then operate gate normally.*

PROTECTION AGAINST ENTRAPMENT

Gate operator category	
Horizontal slide, vertical lift, and vertical pivot	Swing and vertical barrier (arm)
Entrapment protection types (a)	Entrapment protection types (a)
A, B1, B2, or D	A, B1, B2, C, OR D
<p>Note-The same type of device shall not be utilized for both entrapment protection means. Use of a single device to cover both the opening and closing directions is in accordance with the requirement; however, a single device is not required to cover both directions. A combination of one Type B1 for one direction and one Type B2 for the other direction is the equivalent of one device for the purpose of complying with the requirements of either entrapment protection means.</p> <p>(a) Entrapment protection types: Type A ó Inherent entrapment protection system. See 31.1.5. Type B1 óNon-contact sensor (photoelectric sensor or the equivalent). See 31.1.6 ó 31.1.9. Type B2 óContact sensor (edge device or the equivalent). See 31.1.7 and 31.1.11 ó 31.1.13. Type C ó Inherent force limiting, inherent adjustable clutch or inherent pressure relief device. See 31.1.15 and 31.2.1.2 (b). Type D óActuating device requiring continuous pressure to maintain opening or closing motion of the gate. See 31.1.16 and 31.1.17.</p>	

Specifications

Model#	PSB M30B			
Operator Size	28" W x 50" T x 132"L			
Operator Weight	1,900 lbs.			
Maximum Barrier Size	108" T x 300"L-780 lbs			
Voltage	Phase	Hz	Cir. Reg. Amps.	Act. Draw
208/240 VAC	1	60	25	19
Operator Speed to 90°	16-20 Seconds			
Hydraulic Fluid	Citgo-CP (this hydraulic fluid is blue in color)			

Note: Minimum Circuit Requirements: 25 amp service at 208 / 240 VAC Single Phase. For wire sizes consult the NEC (National Electric Code).

Note: If your installation requires 110 VAC add a neutral wire.

Note: Hydraulic pump pressure factory set at 450 PSI. Do exceed this setting.

MADE IN U.S.A.

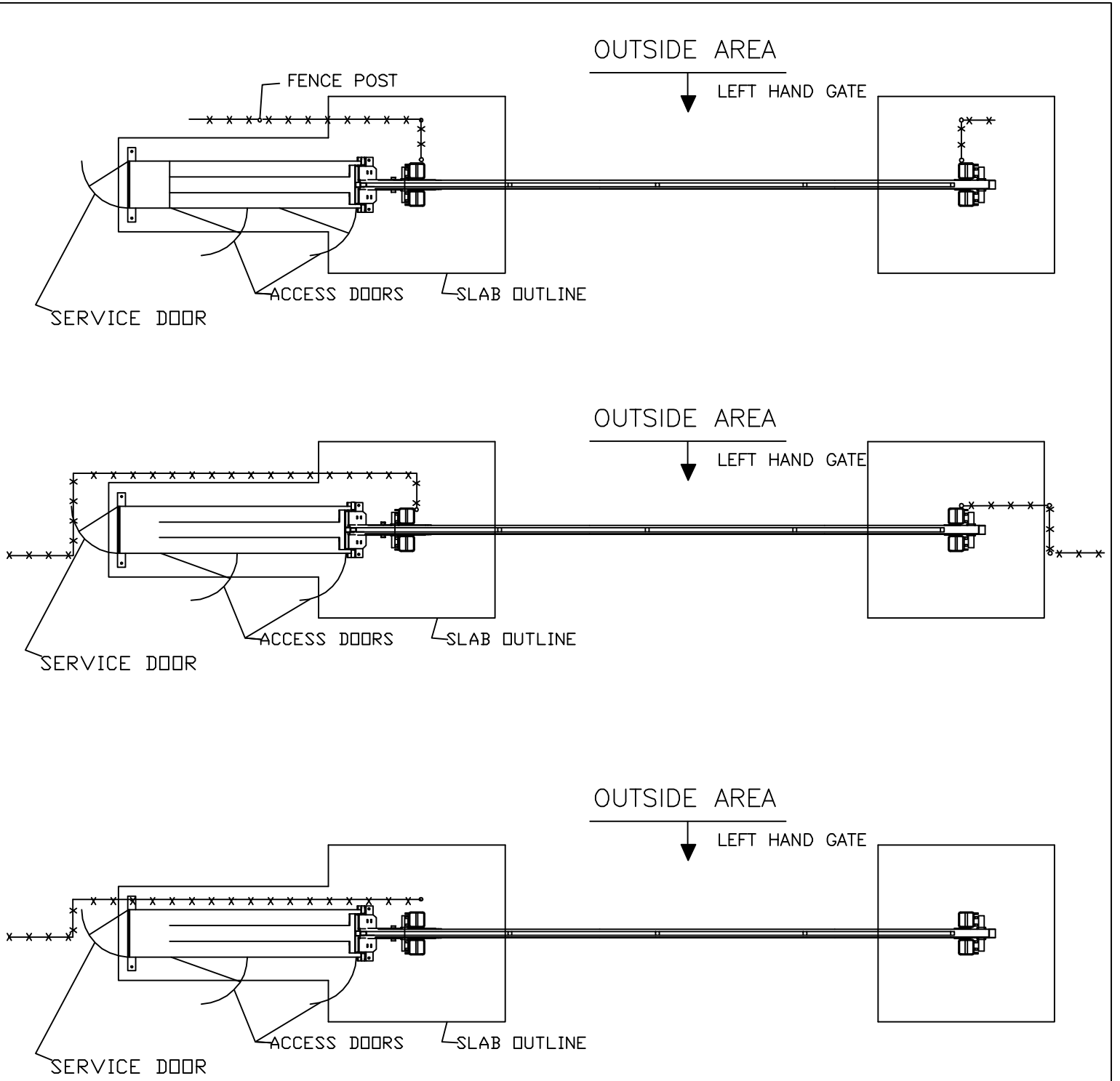

INDICATED ARE THREE MOST COMMON WAYS TO SET A TILT-A-WAY GATE
 INDIVIDUAL CONDITIONS MAY REQUIRE A SPECIAL ARRANGEMENT

**ALTERNATE FENCE SCHEMES
 PSB M30B**

GENERAL INFORMATION

The PEO202P Ideal logic timer board allows numerous programmable functions in various combinations (See Universal Commercial Logic Function Chart). This logic board contains an adjustable time for automatic closing which is adjustable from 1 second to 4 minutes.

When the time function is selected (Switch #3 ON), the timing sequence starts when the gate activates the open limit switch. (At this time the TIMER ACTIVE LIGHT comes ON.) The gate will automatically close after a predetermined time. The timing range is adjustable from 1 second to 4 minutes. The timer is reset by activating any input, which is selected to set the timer. Any combination of inputs will allow you to have more switches ON than are shown for any one input. For example: Input #2 SAFETY (Stop and Reverse) plus input #8 TIMER (Open and Always Set Timer). Switch #3 and switch #5 will both be ON.

GENERAL CIRCUIT BOARD CONNECTIONS

The numbers below refer to the terminal strip (#1 - #15) in the gate operator. All inputs are normally open.

SAFETY

Terminals 2 and 3 In the open position, this input will prevent the gate from closing, or if the timer is used, hold the timer until the input is cleared. In the closing cycle, activation of this input will reverse the gate to full open position, and if the timer is used, set and hold the timer until the input is cleared.

AUX TIMER

Terminals 2 and 4 this input is active only when timer circuit is used. In the open position, activation of this input will hold the timer until the input is cleared. In the closing cycle, activation of this input will reverse the gate to full open position, set the timer and hold the time until the input is cleared.

TIMER

Terminal 2 and 5 This input is active only when the timer circuit is used. When the gate is in the closed position activation of this input will open the gate and set the time. In the open position, this input will hold the timer until the input is cleared. In the closing cycle, activation of this input will reverse the gate to full open position, set the timer and hold the timer until the input is cleared.

ELECTRICAL LOGIC TIMER BOARD GENERAL CAPABILITY

TIMER BOARD

Terminal 2 and 6 This input is active only when the timer circuit is used. When the operator is in the full open position, activation of this input will hold the timer until the input is cleared. This input will NOT reverse the gate when the operator is in the closing cycle.

SINGLE BUTTON

Terminal 2 and 11 When in the closed position, activation of this input will open gate. When in the opening cycle, activation of this input will stop the gate. If gate is stopped in mid travel, this input will open the gate when activated. In the full open position, activation of this input will close the gate. In the closing cycle, this input will reverse the gate to the full open position.

CLOSE

Terminal 2 and 12 When the gate is in the full open position or stopped in mid travel, activation of this input will close the gate.

OPEN

Terminal 2 and 13 When the gate is in the full closed position or stopped in mid travel, activation of this input will open the gate.

STOP

Terminal 7 and 8 This is a NORMALLY CLOSED circuit. Anytime the stop circuit is opened, all functions of the logic board will cease. When the circuit is once again closed, the desired input will have to be reactivated to start the function once again.

	INPUT:	FUNCTION:	SWITCH POSITION										
			1.	2.	3.	4.	5.	6.	7.	8.			
1.	SAFETY	WHEN DOOR IS OFF DOWN LIMIT STOPPING SAFETY ONLY	OFF	OFF	OFF	OFF	OFF	OFF	OFF	OFF	OFF	OFF	OFF
2.	SAFETY	WHEN DOOR IS OFF DOWN LIMIT STOP AND REVERSE	OFF	OFF	OFF	OFF	OFF	ON	OFF	ON	OFF	OFF	OFF
3.	SAFETY	WHEN DOOR IS OFF DOWN LIMIT INSTANT REVERSE	OFF	OFF	OFF	OFF	OFF	ON	OFF	ON	ON	OFF	OFF
4.	SAFETY	WHEN DOOR IS OFF DOWN LIMIT STOP AND REVERSE AND SET TIMER	OFF	ON	ON	OFF	OFF	ON	OFF	ON	OFF	OFF	OFF
5.	SAFETY	WHEN DOOR IS OFF DOWN LIMIT INSTANT REVERSE AND SET TIMER	OFF	ON	ON	OFF	OFF	ON	OFF	ON	ON	OFF	OFF
6.	AUX. TIMER	WHEN DOOR IS OFF DOWN LIMIT OPEN AND SET TIMER STOP AND REVERSE AND SET TIMER	OFF	OFF	ON	OFF	OFF	OFF	OFF	OFF	OFF	OFF	OFF
7.	AUX. TIMER	WHEN DOOR IS OFF DOWN LIMIT OPEN AND SET TIMER INSTANT REVERSE AND SET TIMER	OFF	OFF	ON	OFF	OFF	OFF	OFF	ON	ON	OFF	OFF
8.	TIMER	OPEN AND ALWAYS SET TIMER STOP AND REVERSE AND SET TIMER	OFF	OFF	ON	OFF	OFF	OFF	OFF	OFF	OFF	OFF	OFF
9.	TIMER	OPEN AND ALWAYS SET TIMER INSTANT REVERSE AND SET TIMER	OFF	OFF	ON	OFF	OFF	OFF	OFF	OFF	ON	OFF	OFF
10.	HOLD	HOLD TIMER RESET TIMER ONLY DURING TIMING PERIOD	OFF	OFF	ON	OFF	OFF	OFF	OFF	OFF	OFF	OFF	OFF
11.	STOP	STOP DOOR / GATE TRAVEL ONLY	OFF	OFF	OFF	OFF	OFF	OFF	OFF	OFF	OFF	OFF	OFF
12.	STOP	STOP DOOR / GATE TRAVEL AND TIMER	OFF	OFF	ON	OFF	OFF	OFF	OFF	OFF	OFF	OFF	OFF
13.	SINGLE BUTTON	OPEN CYCLE OPEN - PARK - OPEN CLOSE CYCLE CLOSE - PARK - OPEN	OFF	OFF	OFF	OFF	OFF	OFF	OFF	OFF	OFF	OFF	ON
14.	SINGLE BUTTON	OPEN CYCLE OPEN - PARK - OPEN CLOSE CYCLE CLOSE - STOP - REVERSE	OFF	OFF	OFF	OFF	OFF	OFF	OFF	OFF	OFF	ON	ON
15.	SINGLE BUTTON	OPEN CYCLE OPEN - PARK - OPEN CLOSE CYCLE CLOSE - INSTANT REVERSE	OFF	OFF	OFF	OFF	OFF	OFF	OFF	OFF	ON	ON	ON
16.	SINGLE BUTTON	OPEN CYCLE SET TIMER WHEN ACTIVATED ON OPEN LIMIT CLOSE CYCLE PARK - OPEN	ON	OFF	ON	ON	ON	ON	OFF	OFF	OFF	OFF	ON
17.	SINGLE BUTTON	OPEN CYCLE OPEN - PARK - OPEN SET TIMER WHEN ACTIVATED ON OPEN LIMIT CLOSE CYCLE STOP AND REVERSE	ON	OFF	ON	ON	ON	ON	OFF	OFF	OFF	ON	ON
18.	SINGLE BUTTON	OPEN CYCLE OPEN - PARK - OPEN SET TIMER WHEN ACTIVATED ON OPEN LIMIT CLOSE CYCLE INSTANT REVERSE	ON	OFF	ON	ON	ON	ON	OFF	OFF	ON	ON	ON
19.	CLOSE	CLOSE DOOR / GATE EVEN WHILE TIMER IS TIMING	OFF	OFF	ON	ON	ON	ON	OFF	OFF	OFF	OFF	OFF
20.	CLOSE	CLOSE DOOR / GATE EXCEPT WHEN TIMER IS TIMING	OFF	OFF	ON	ON	ON	ON	ON	ON	OFF	OFF	OFF
21.	OPEN	OPEN DOOR / GATE ONLY	OFF	OFF	ON	ON	ON	ON	ON	ON	OFF	OFF	OFF
			NOT DEPENDENT ON ANY SWITCH POSITION										

**TILT-A-WAY
HYDRAULIC OPERATOR
BASIC ELECTRICAL HARDWARE
DRAWING PSB M30B-200**

	PART NO.	DESCRIPTION	QTY
1	PEO600	ENCLOSURE	1
2	FGO600	PANEL MOUNTING	1
3	PEO602-1	CIRCUIT BREAKER	1
4	PEO602A	C/B BRACKET	1
5	PEO274	CONTACTOR	2
6	PEO603A	INTERLOCK-CONTACTOR	1
7	PEO604	OVERLOAD RELAY	1
8	PEO214	SCOCKET LOOP DETECTOR (optional)	3
9	PEO606	RELAY 8 PIN	2
10	PEO606A	SOCKET 8 PIN	2
11	PEO213	TRANSFORMER	1
12	PEO608	P/B CARTRIDGE	1
13	PEO608A	P/B OPERATOR	1
14	PEO202P	TIMER BOARD	1
15	PEO611	SAFETY SWITCH	4
16	PEO620	END ANCHOR – TERMINAL BLOCK	1
17	PEO621	GRE/YEL BLOCK- TERMINAL BLOCK	2
18	PEO622	BLACK BLOCK-TERMINAL BLOCK	3
19	PEO623	RED BLOCK- TERMINAL BLOCK	3
20	PEO625	FUSE BLOCK- TERMINAL BLOCK	1
21	PEO625A	FUSE 1 AMP 250 VOLT-TERMINAL BLOCK	1
22	PEO626	BARRIER- FUSE BLOCK	1
23	PEO627	DOUBLE BLOCK- TERMINAL BLOCK (connected)	16
24	PEO628	DOUBLE BLOCK- TERMINAL BLOCK (not connected)	2
25	PEO629	BARRIER- TERMINAL BLOCK	1
26	PEO630	JUMPER- TERMINAL BLOCK	1
27	PEO631	JUMPER- TERMINAL BLOCK	1
28	PEO632	JUMPER- TERMINAL BLOCK	2
29	PEO633	MARKER- 1 THRU 13	1
30	PEO634	MARKER- G,N,L1,L2,LL1,LL2,	1
31	PEO635	T DUCT PVC 48"- WIRE TRACK	1
32	PEO636	COVER PVC 48"- WIRE TRACK	1
33	PEO637	DIN TRACK 34"	1
34	PEO231	ELBOW CONNECTION 90 DEGREES	2
35	PEO235	CONNECTION STRAIGHT	2
36	PEO223	3/8" ROMEX	4
37	PEO275	3/4" ROMEX	2
38	N/A	8 X 1/2" SELF DRILLING PHILLIPS SCREW	19

ENCLOSURE OUTLINE

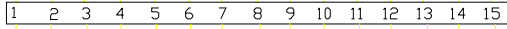
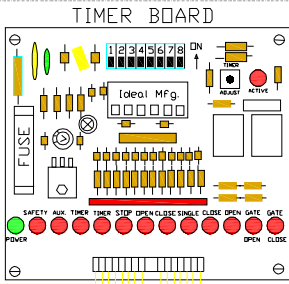

FRONT OF SWITCH

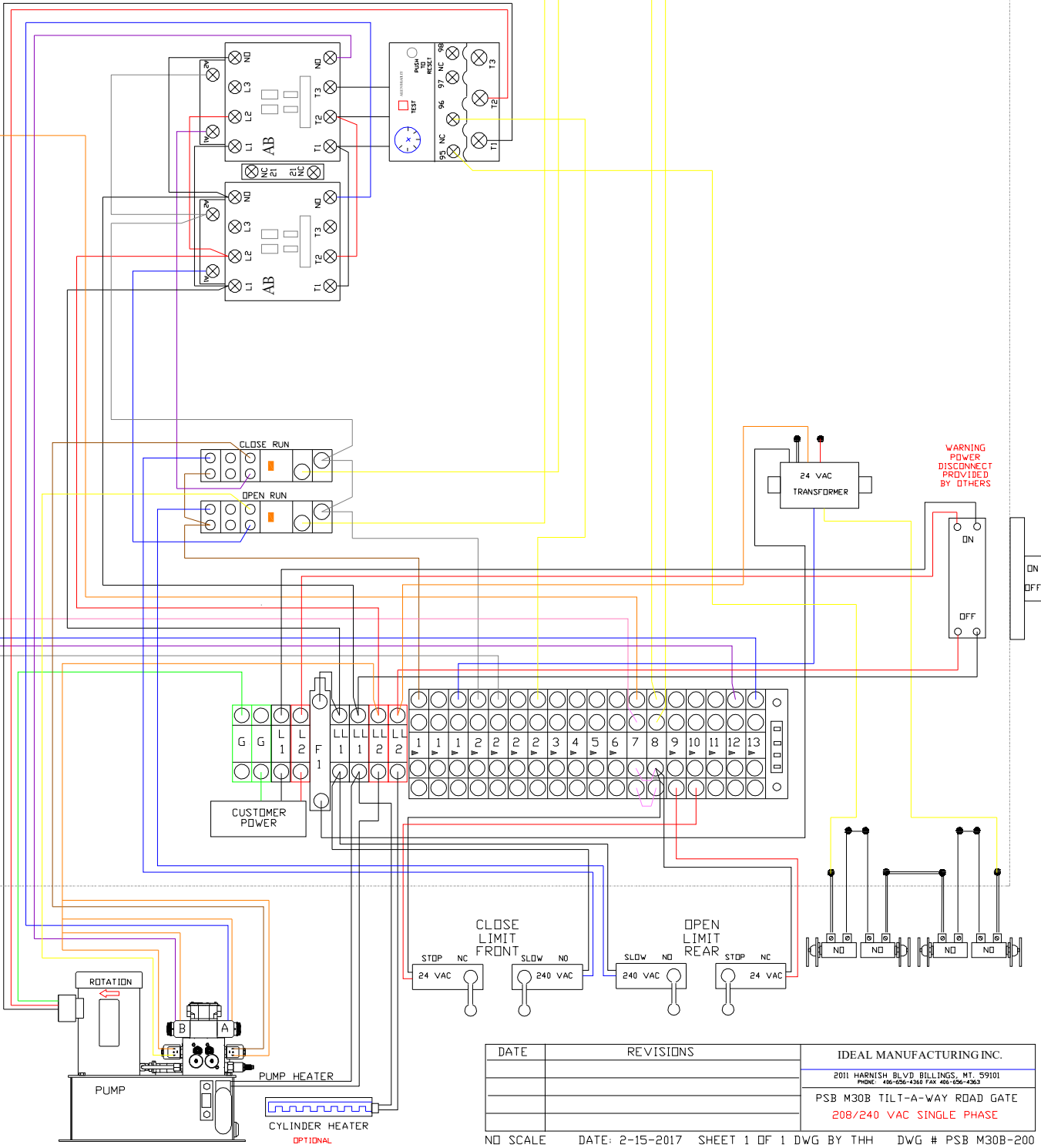

WARNING
POWER
DISCONNECT
PROVIDED
BY OTHERS

F 1
FUSE 1 AMP / 250 VOLT

LEGEND

- WHITE
- RED
- YELLOW
- GREEN
- BLUE
- BLACK
- ORANGE
- BROWN
- PURPLE
- GREY
- PINK

DATE	REVISIONS	IDEAL MANUFACTURING INC.
		2011 HARNISH BLVD BILLINGS, MT, 59101 PHONE: 406-656-4360 FAX: 406-656-4363
		PSB M30B TILT-A-WAY ROAD GATE 208/240 VAC SINGLE PHASE
NO SCALE	DATE: 2-15-2017 SHEET 1 OF 1 DWG BY THH	DWG # PSB M30B-200

**TILT-A-WAY
OPERATOR FIELD INSTALLATION
DRAWING PSB M30B 102
MODEL PSB M30B**

REF. NO.	DESCRIPTION
-----------------	--------------------

**Note: If gate does not operate on first try, but hydraulic pump runs
switch 2 power lines to reverse pump rotation.**

- 1 Control pedestal **PSM M30B**
NOTE: Will withstand and estimated 100 MPH wind in most soil conditions.
- 2 Electrical conduit area. Stub in electrical supply, 25 Amp service.
- 3 Four anchor bolts ¾" diameter with 2" projection.
- 4 Concrete foundation (see drawing supplied for your application from Ideal Mfg., Inc.).
- 5 Right Stanchion.
- 6 Left Stanchion.
- 7 Base plate.

**TILT-A-WAY
HYDRAULIC OPERATOR INSTALLATION PROCEDURE FOR GATE THAT IS SHIPPED
UNASSEMBLED DRAWING PSB M30B 102**

1. Remove all materials used for protection during shipment.
2. Place operator frame on level ground. Insure operator frame does not move when performing steps 4 through 9. Remove lifting hook.
3. Open rear access door to expose spring tension adjustment screws.
4. Find two fluid bypass valves located on top of hydraulic unit, place in open position.
5. Back off all four spring tension screws to provide slack in tension cables. (1 5/8" socket needed)
6. Rotate barrier carriage to down position. Remove pivot shaft with attached components. Install barrier and secure to vertical carriage post with three bolts and bolt at outer end of carriage horizontal channel.
7. Place plastic rub washer over pivot shaft collar on carriage. Align cylinder rod end bearing with collar and insert pivot shaft from far side. Secure with flat washer, lock washer and bolt.
8. Tighten spring tension screws while inspecting cables for proper wrap around balance sheaves. When slide members have reached marks indicated on tracks. Proper balance tension will have been achieved. If at a later date minor adjustment should be required, refer to balance system adjusting section.
9. Set operator and barrier per Installation Procedure on page 9 drawing PSB M30B 102.
10. Perform required electrical connections in accordance with diagrams shown in this manual.
11. Position fluid bypass valves to closed setting, close and secure access door.
12. If gate fails to function properly, contact manufacturer's representative.

**TILT-A-WAY
HYDRAULIC OPERATOR INSTALLATION PROCEDURE FOR GATE THAT IS SHIPPED
ASSEMBLED DRAWING PSB M30B 102**

1. Remove all materials used for protection during shipment.
2. Set operator and barrier per Installation Procedure on page 9 drawing PSB M30B 102.
3. Perform required electrical connections in accordance with diagrams shown in this manual.
4. Position fluid bypass valves to closed setting, close and secure access door.
5. If gate fails to function properly, contact manufacturer's representative.

Tilt-A-Way
 MODEL PSB M30B
 ALUMINUM BARRIER
 HYDRAULIC VERTICAL PIVOT GATE
 RIGHT HAND INSTALLATION SHOWN
 LEFT HAND OPPOSITE

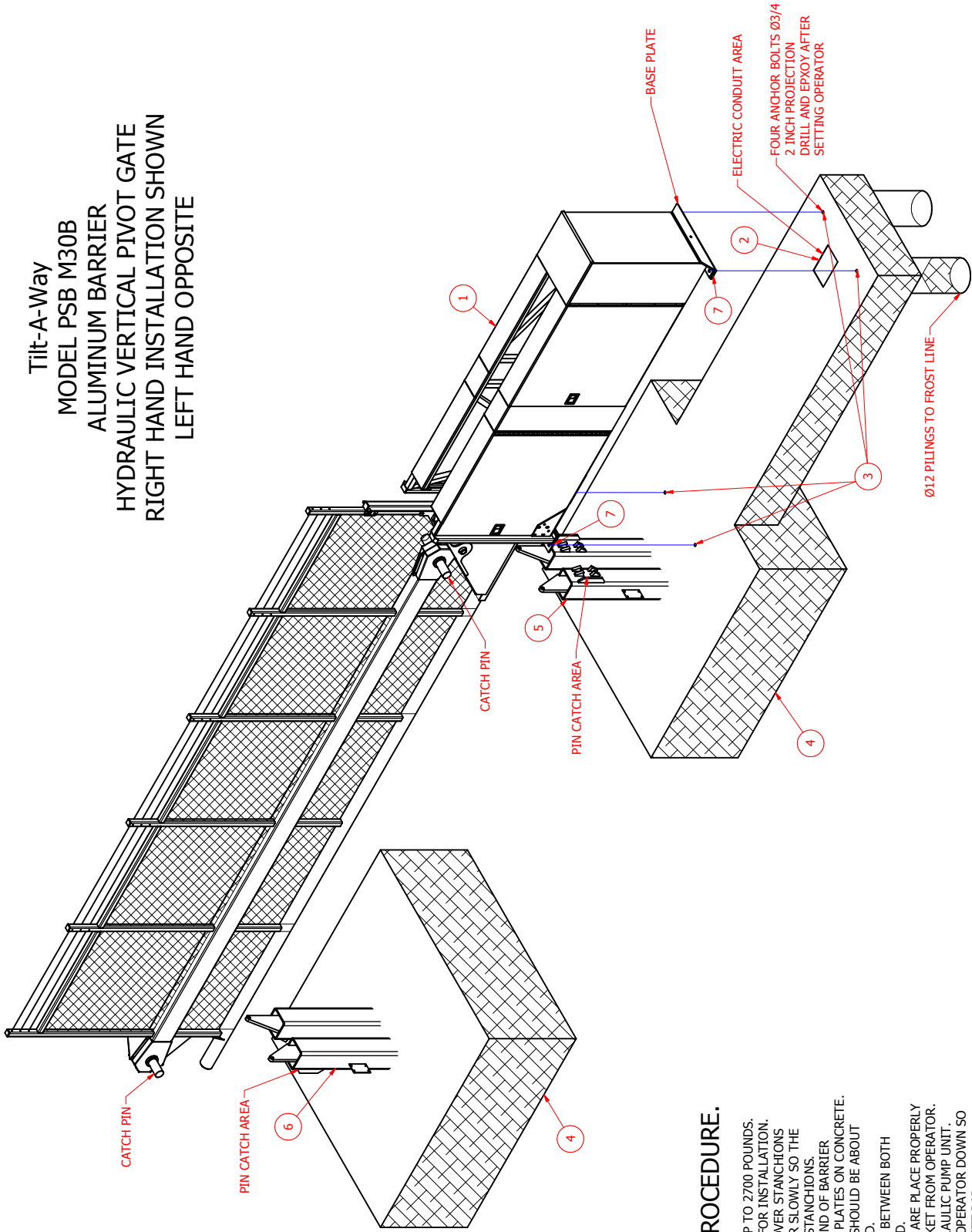

INSTALLATION PROCEDURE.

MODEL PSB M30B CAN WEIGH UP TO 2700 POUNDS. USE SUITABLE LIFTING DEVICE FOR INSTALLATION. LIFT OPERATOR AND BARRIER OVER STANCHIONS LOWER OPERATOR AND BARRIER SLOWLY SO THE BARRIER IS IN BETWEEN BOTH STANCHIONS. PLACE BLOCKING UNDER FREE END OF BARRIER TO KEEP BOTH OPERATOR BASE PLATES ON CONCRETE. THE FRONT OF THE OPERATOR SHOULD BE ABOUT 22 INCHES AWAY FROM BOLLARD. BARRIER SHOULD BE CENTERED BETWEEN BOTH STANCHIONS. ADJUST AS NEEDED. WHEN OPERATOR AND BARRIER ARE PLACE PROPERLY REMOVE YELLOW LIFTING BRACKET FROM OPERATOR. OPEN MANUAL VALVES ON HYDRAULIC PUMP UNIT. HOLD CONTROL PANEL END OF OPERATOR DOWN SO IT WILL NOT RAISE OFF CONCRETE PAD. FROM FREE END OF BARRIER RAISE THE BARRIER BY HAND TO CHECK THAT BOTH PINS CLEAR STANCHION CATCHES. IF THERE IS ANY INTERFERENCE CORRECT AS NEEDED. WHEN PROPERLY ALIGNED LOWER BARRIER BACK ON BLOCKING. DRILL HOLES IN CONCRETE THROUGH HOLES IN BASE PLATES FOR ANCHOR BOLTS. FOLLOW EPOXY MANUFACTURER INSTRUCTIONS FOR ANCHOR BOLTS DO NOT OPERATE GATE UNTIL EPOXY HAS FULLY CURED.

NOTE: PLACE ALL CONDUITS FOR AUXILIARY EQUIPMENT BEFORE POURING CONCRETE

DRAWN	11/23/2011	IDEAL MFG., INC.	
CHECKED	2011 Harmish Blvd.	Billings MT 59101	
QA	1/12/2016	TITLE	
MFG		PSB M30B INSTALLATION	
APPROVED		SIZE	DWG NO
		C	PSB M30B 102
		SCALE	
			REV

**TILT-A-WAY
MODEL PSB M30B
HYDRAULIC OPERATOR BALANCE SYSTEM ADJUSTMENT
DRAWING PSB M30B-103**

TILT-A-WAY road gate must be balanced to offer the least amount of resistance against movement at both up and down extreme positions or combination of both.

Balance adjustment is accomplished by cable tension, cable sheave position or combination of both.

Two cable systems are incorporated and any adjustments preformed at one side may need to be duplicated on the opposite side. There are two springs (one upper spring and one lower spring) and one cable per system.

SAFETY WARNINGS-VERY IMPORTANT

- 1. Before performing any maintenance or adjustment, open main power disconnect switch located adjacent to control panel enclosure. Prior to performing any adjustment, hydraulic fluid bypass valves must be placed in open position.**
- 2. Any adjustment preformed on cable sheave must be preceded by the release of all cable tension at spring connections. When adjusting tension on cable systems both upper and lower springs per system must be adjusted in small equal amounts.**

CONDITIONS AND SOLUTIONS

- 1. Condition: Gate heavy at both up and down positions.
Solution: Increases cable tension.**
- 2. Condition: Gate light at both up and down positions
Solution: Decrease cable tension.**
- 3. Condition: Gate heavy at down position only.
Solution: Lower cable sheave and increase cable tension.**
- 4. Condition: Gate light at down position only.
Solution: Raise cable sheave and decrease cable tension.**
- 5. Condition: Gate heavy at up position only.
Solution: Raise cable sheave and decrease cable tension.**
- 6. Condition: Gate light at up position only.
Solution: Lower cable sheave increase cable tension.**
- 7. Condition: Gate heavy at intermediate positions.
Solution: Move cable sheave forward.**
- 8. Condition: Gate light at intermediate positions.
Solution: Move cable sheave rearward.**

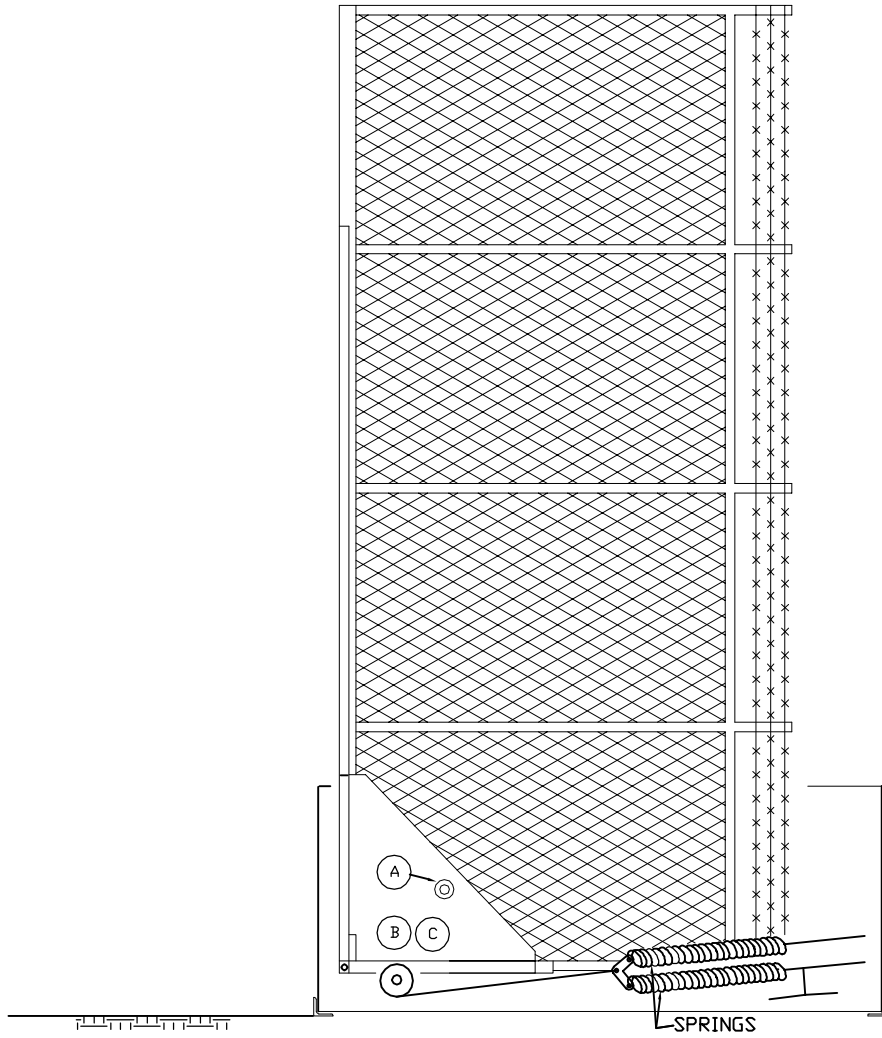

UP

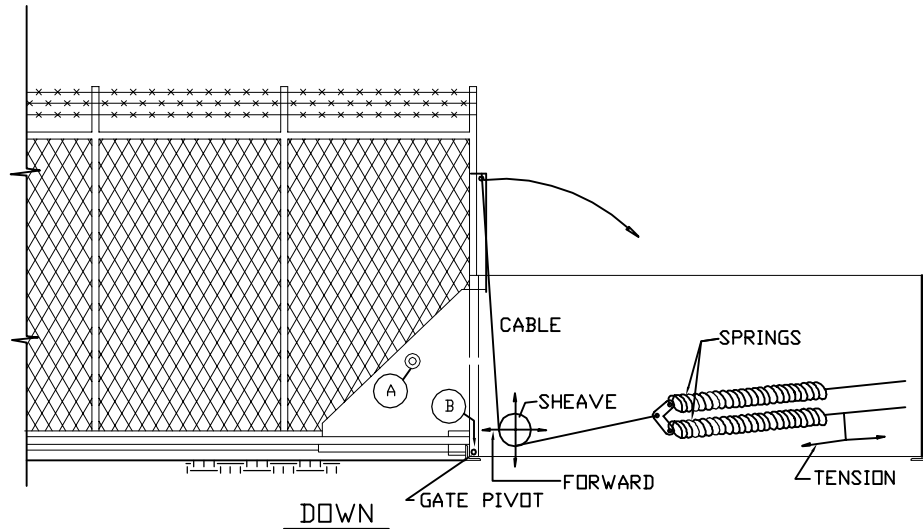

DOWN

TILT-A-WAY MODEL PSB M30B HYDRAULIC OPERATOR
BALANCE SYSTEM ADJUSTMENT

**TILT-A-WAY
MODEL PSB M30B
OPERATOR GENERAL ARRANGEMENT
DRAWING # PSB M30B-106**

REF NO.	DESCRIPTION	
1	Control Pedestal Frame	Covers see Drawing # PSB M30B-119 Page 33
2	Barrier Unit	See Drawing # PSB M30B-107 Page 18
3	Hydraulic Pump & Reservoir	See Drawing # PSB M30B-112 Page 25, Page 29
4	Electrical Control Enclosure	See Drawing # PSB M30B-200E Page 7
5	Barrier Carriage	See Drawing # PSB M30B-104 Page 15
6	Balance System Cable & Sheave Assembly.	See Drawing # PSB M30B-108 Page 19
7	Balance System Cable Guide Assembly.	See Drawing # PSB M30B-109 Page 20
8	Balance System Tension Cable	See Drawing # PSB M30B-108 Page 19
9	Balance system Tension Spring	See Drawing # PSB M30B-111 Page 23
10	Balance System Spring Tension Adjusting Limit	See Drawing # PSB M30B-111 Page 23
11	Balance System Spring Tension Release	Power Off Safety Switch. See Drawing # PSB M30B-111 Page 23
12	Hydraulic Actuating Cylinder	See Drawing # PSB M30B-105 Page 17
13	Cylinder Control Actuating System	See Drawing # PSB M30B-105 Page 17

**RECOMMENDED GENERAL MAINTENANCE
DRAWING # PSB M30B-106**

Check all safety devices for proper function monthly.

Check interior of pedestal for any accumulation of trash caused by blowing wind and remove.

On regular basis the following maintenance steps should be performed (**Monthly**).

1. Check hydraulic fluid level with site gauge on oil reservoir. Level to be approximately 2 ½" below the top of the pipe. If required, add Citgo-CP hydraulic fluid (see specifications on page 2). Check with cylinder retracted (gate open).
2. Inspect cables for broken strands. Replace cable if there are five broken strands per lay or ten broken strands over all.
3. Clean and lubricate spring tension screws with (general purpose grease) to prevent rusting.
4. Lubricate with (general purpose grease such as a bearing grease) all points equipped with zerk fitting.
 - A. Barrier carriage pivot bearing. Two locations.
 - B. Cylinder anchor pivot.
 - C. Cylinder rod end pivot bearings.

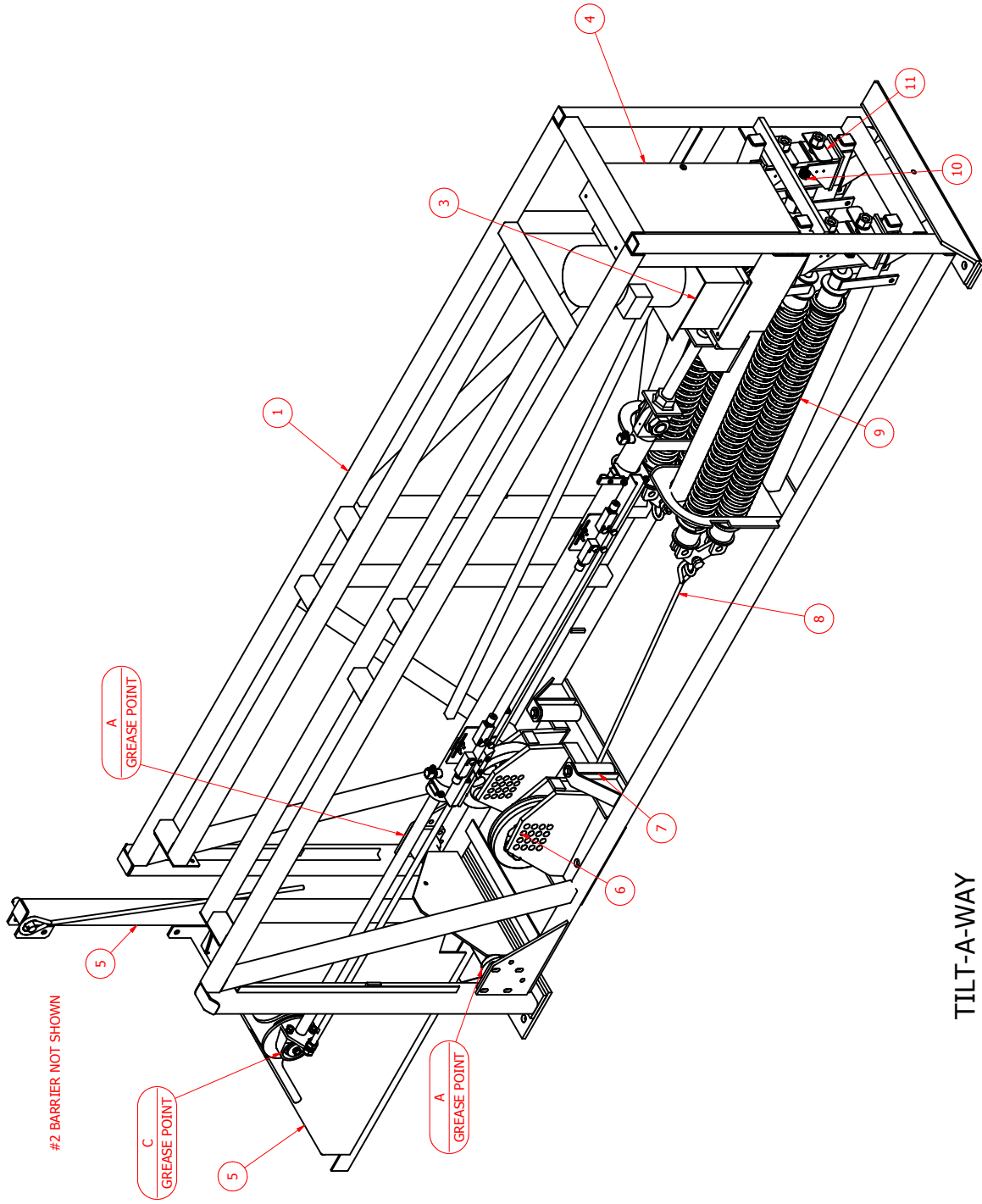

TILT-A-WAY
 MODEL PSB M30B
 OPERATOR GENERAL ARRANGEMENT

DRAWN T.Henty		4/12/2010	IDEAL MFG., INC.	
CHECKED		1/12/2016	TITLE	
QA			PSB M30B OPERATOR GENERAL ARRANGEMENT	
MFG			SIZE	
APPROVED			C	
			DWG NO	
			PSB M30B 106	
			SCALE	
			SHEET 1 OF 1	

**TILT-A-WAY
MODEL PSB M30B
BARRIER CARRIAGE**

DRAWING # PSB M30B-104

REF NO.	PART NO.	DESCRIPTION	REQ'D NO.
1	ID1006	3/16 X 1 1/2 Stainless Cotter Pin	2
2	N/A	1ö SAE Flat Washer	4
3	N/A	5/8-11 X 3 1/4 Hex Bolt	3
4	N/A	5/8-11 Nylock	3
5	N/A	1/2-13 x 5 1/2 Hex Bolt	1
6	N/A	½-13 Nylock	1
7	N/A	1/2-13 Hex Nut	8
8	N/A	1/2 Lock Washer	8
9	N/A	1/2-13 X 1 1/2 Hex Bolt	8
10	N/A	1/2-13 X 1 1/4 Hex Bolt	1
FGO198	FGO198	Rod End Pivot Shaft	1
FGO200	FGO200	Bearing Sleeve Pressure Washer	1
FGO641	FGO641	Plastic Rub Washer	1
FGO645	FGO645	PSB M50 Carriage	1
PEO950	PEO950	Flange Bearing	2
PEO952	PEO952	Cable	2

TILT-A-WAY MODEL PSB M30B CARRIAGE

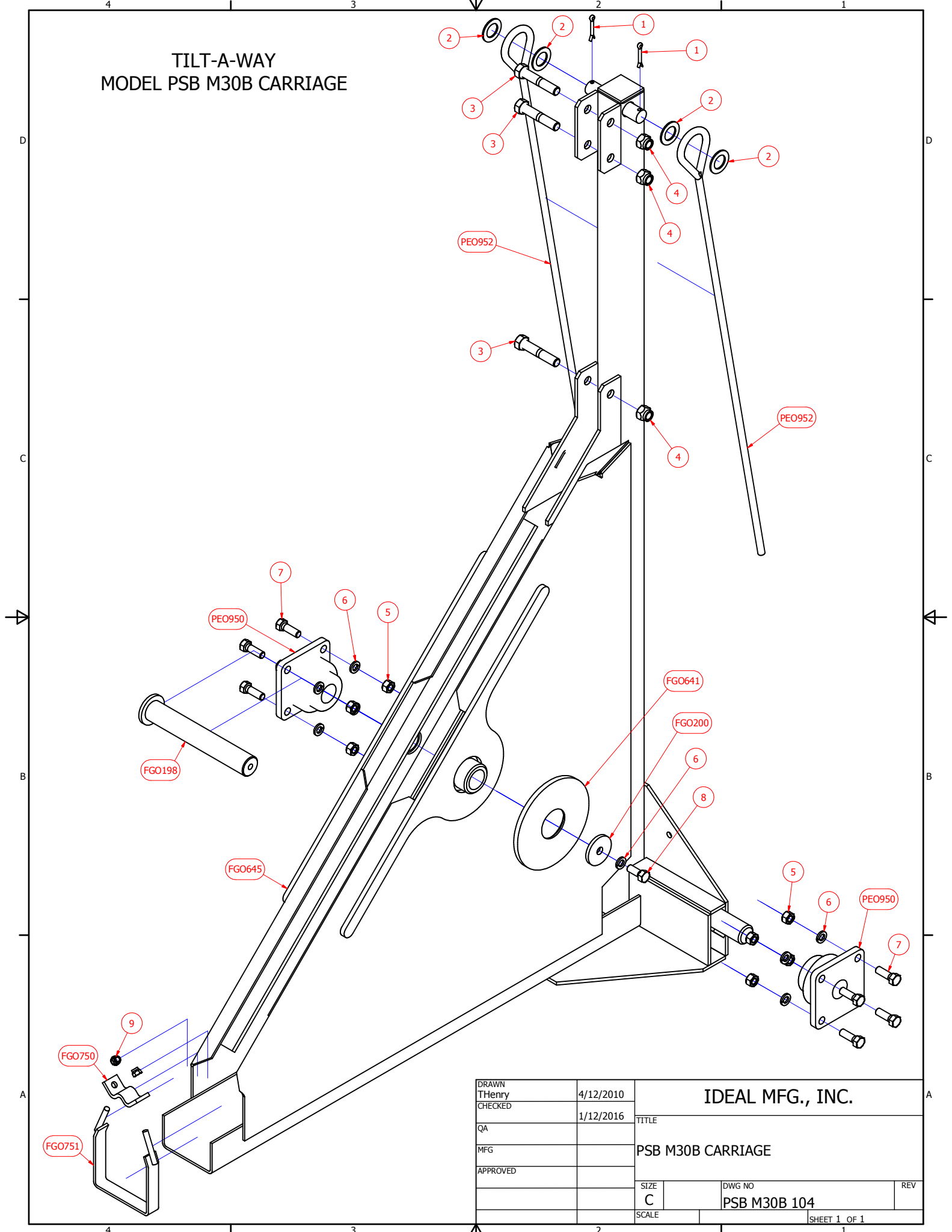

DRAWN	THenry	4/12/2010	IDEAL MFG., INC.	
CHECKED		1/12/2016	TITLE	
QA			PSB M30B CARRIAGE	
MFG			SIZE	DWG NO
APPROVED			C	PSB M30B 104
			SCALE	REV
				SHEET 1 OF 1

**TILT-A-WAY
HYDRAULIC OPERATOR
ACTUATING CYLINDER WITH COMPONENTS
PSB M30B
Drawing PSB M30B 105**

REF NO.	PART NO.	DESCRIPTION	REQ'D NO.
1	TWO534	Hydraulic Cylinder	1
2	FGO187BE	Foot Clevis Assembly	1
3	FGO187BE1	Support Plate Extended Operator	1
4	TWO118	Rod End Pivot Bearing	1
5	FGO198	Rod End Pivot Shaft	1
6	FGO641	Plastic Rub Washer	1
7	FGO208	Bearing Sleeve Pressure Washer	1
8	FGO686	Actuator Track	1
9	TWO119	Actuator Track Clamp	2
10	FGO685	Adjustable Mount Plate	2
11	PEO612	Cord connector	4
12	PEO963	Limit Switch	4
13	FGO687A	Actuator Rod	1
14	FGO194	Plastic Runner Bearing	2
15	ID1030	Grease Zerk	1
16	ID1031	ø Ring	4
17	FGO211	Hydraulic Hose Support	1
18	FGO206	Hydraulic Hose Clamp	1
19	NA	1/2" Lock washer	2
20	N/A	1/2" X 13 X 1" Hex Head Bolt	3
21	N/A	3/8" Lock washer	5
22	N/A	3/8" Hex Nut	5
23	NA	1/4" X 1 1/4" Hex Head Bolt	4
24	NA	1 1/2" Hex Nut	2
25	NA	1/4" X 1" Hex Head Bolt	1
26	NA	1/4" Lock washer	5
27	NA	1/4" SAE Flat Washer	4
28	NA	1/4" Hex Nut	5
29	N/A	3/4" Lock washer	1
30	N/A	3/4" Hex Nut	2
31	N/A	8-32 X 1 1/2" Machine Screw	8
32	N/A	8-32 Kep Nut	8
33	N/A	5/16-18 X 2 Hex Bolt	2
34	FGO688	Actuator Block	1
35	TWO154	90 Deg. Elbow	2
36	N/A	1 1/2-6 x 4 Hex Bolt	1
37	N/A	1 1/2-6 Hex Jam Nylock Nut	1

TILT-A-WAY
PSB M30B
ACTUATING CYLINDER
WITH COMPONENTS

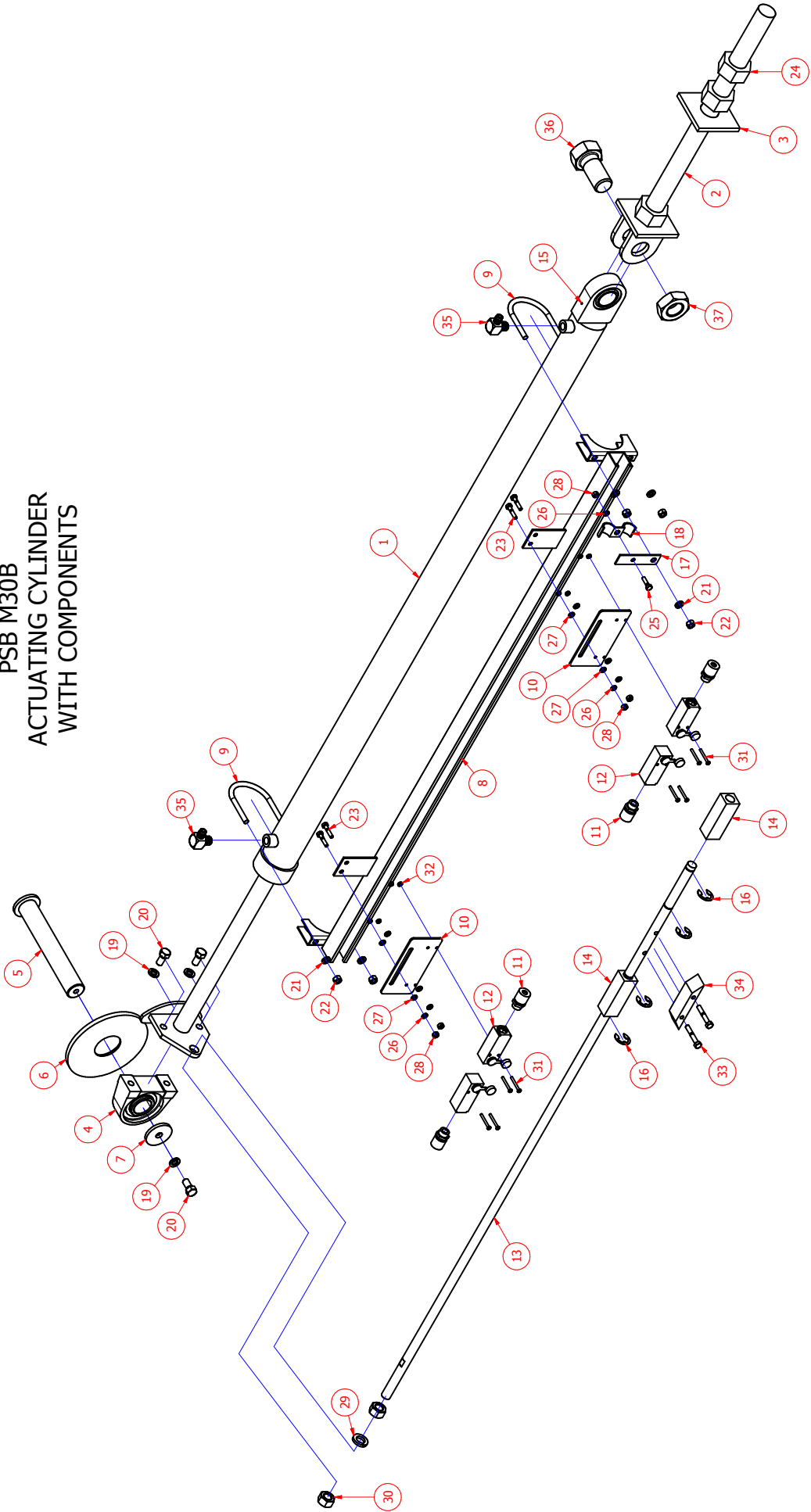

DRAWN	1/6/2016	Ideal Mfg., Inc.	
T Henry	1/12/2016	2011 Harnish Blvd. Billings MT 59101 Tel: (406) 656-4360	
CHECKED		TITLE	
QA		PSB M30B ACTUATOR	
MFG		SIZE	DWG NO
APPROVED		C	PSB M30B 105
		SCALE	REV
			SHEET 1 OF 1

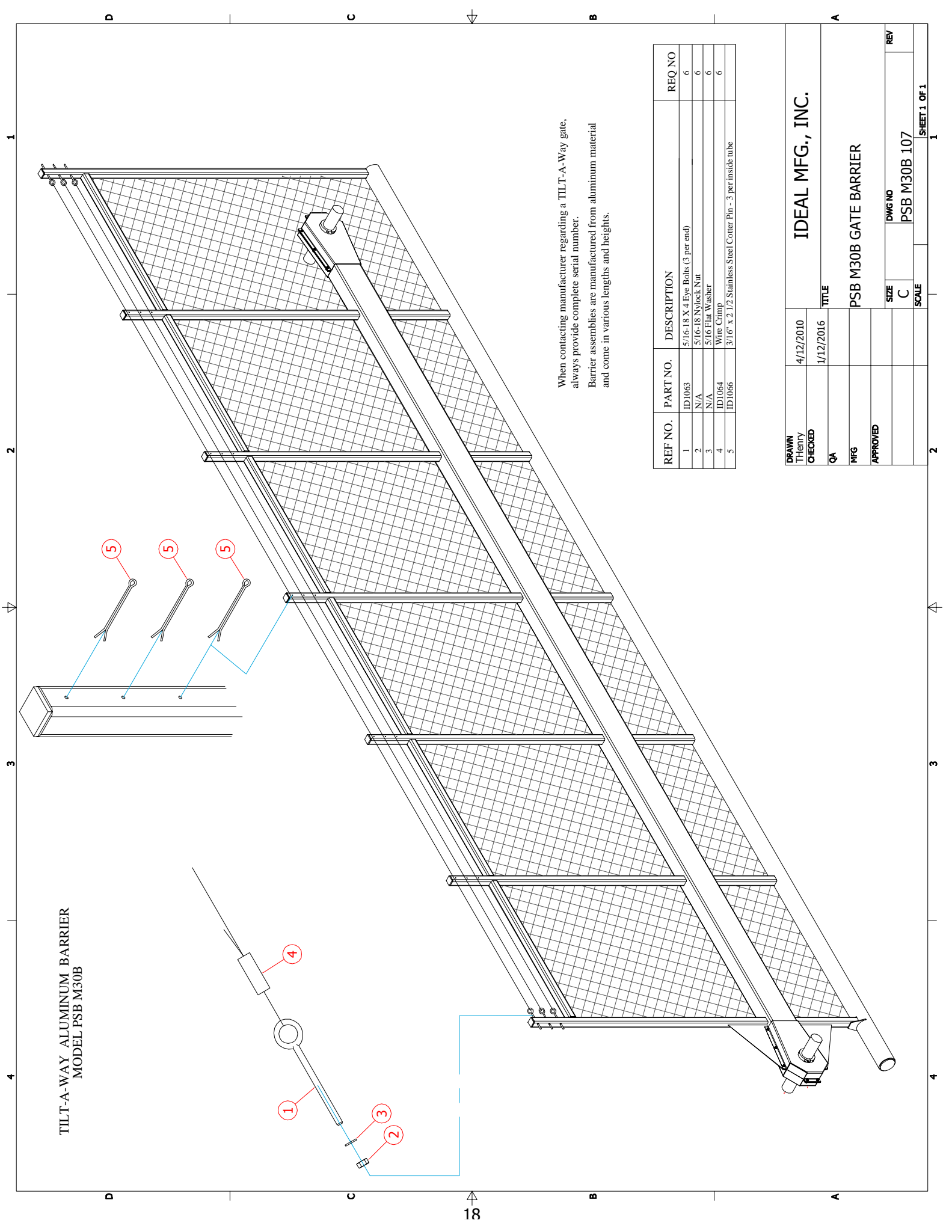

TILT-A-WAY ALUMINUM BARRIER
MODEL PSB M30B

When contacting manufacturer regarding a TILT-A-Way gate, always provide complete serial number.
Barrier assemblies are manufactured from aluminum material and come in various lengths and heights.

REF. NO.	PART NO.	DESCRIPTION	REQ NO
1	ID1063	5/16-18 X 4 Eye Bolts (3 per end)	6
2	N/A	5/16-18 Nylock Nut	6
3	N/A	5/16 Flat Washer	6
4	ID1064	Wire Clamp	6
5	ID1066	3/16" x 2 1/2 Stainless Steel Cotter Pin - 3 per inside tube	6

DRAWN Thermy	4/12/2010		
CHECKED	1/12/2016		
QA		TITLE	
MFG		PSB M30B GATE BARRIER	
APPROVED			
		SIZE	DWG NO
		C	PSB M30B 107
		SCALE	REV

IDEAL MFG., INC.

TILT-A-WAY
MODEL PSB M30B
BALANCE SYSTEM CABLE & SHEAVE

Parts List			
REF. NO.	PART NUMBER	DESCRIPTION	QTY
1	N/A	PSB M30A SHEAVE PLATE ON OPERATOR FRAME	1
2	N/A	5/8-11 NYLOCK NUT	2
FGO648	FGO648	PSB M30 SHEAVE	2
FGO649	FGO649	BUSHING	2
PEO951	PEO951	BEARING	2
PEO952	PEO952	CABLE	2
PEO957	PEO957	3/4 X 3 1/4 SHOULDER BOLT	2

NOTE: When ordering cables, make sure you have the serial number in order for manufacturer to ship the right size cables.

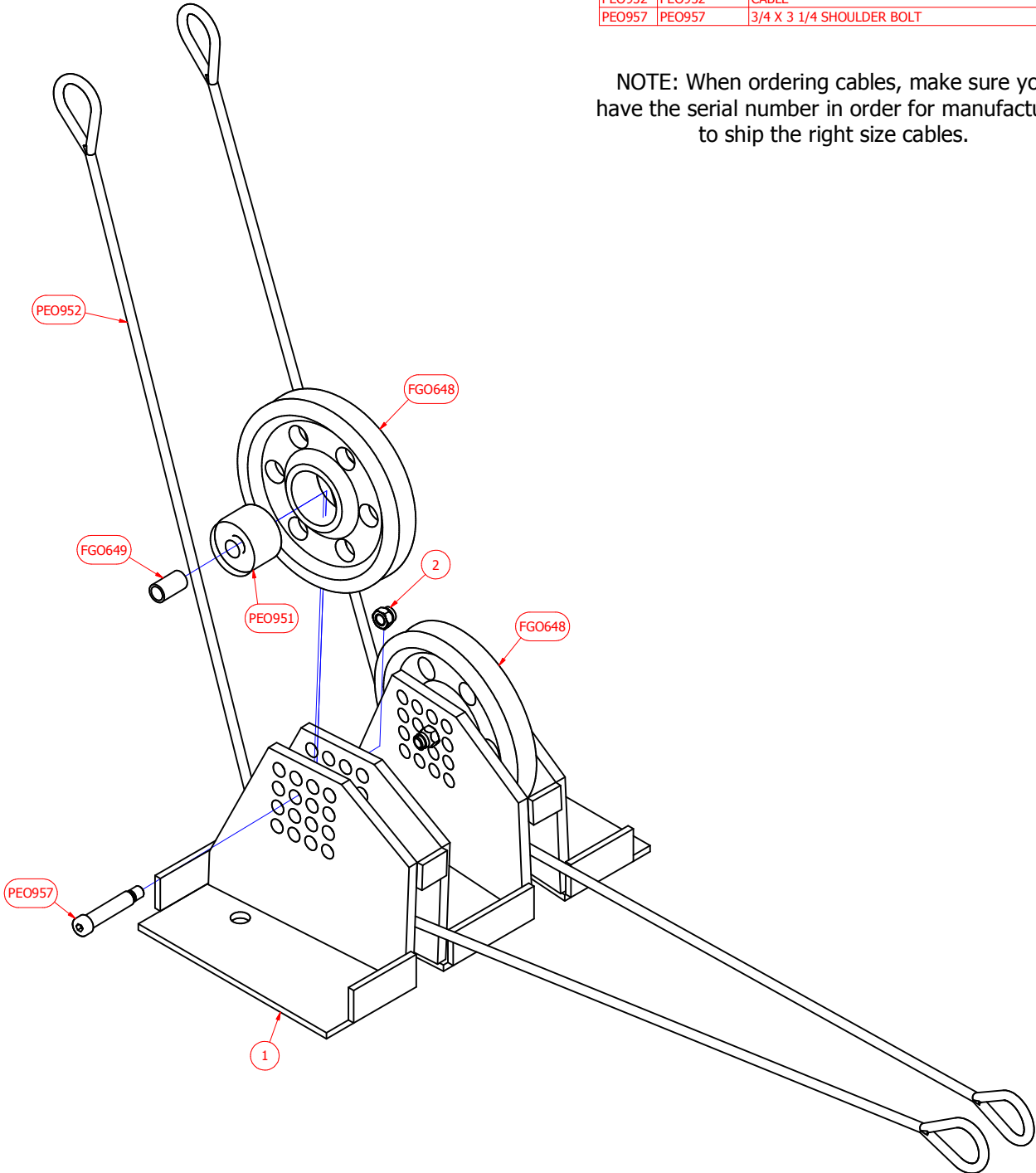

DRAWN	THenry	4/13/2010	IDEAL MFG., INC.	
CHECKED		1/12/2016	TITLE	
QA			BALANCE SYSTEM CABLE & SHEAVE	
MFG			SIZE	DWG NO
APPROVED			C	PSB M30B 108
			SCALE	SHEET 1 OF 1

TILT-A-WAY MODEL PSB M30B BALANCE SYSTEM CABLE GUIDE

Parts List			
REF. NO.	PART NUMBER	DESCRIPTION	QTY
1	N/A	SUPPORT CARRIAGE ON OPERATOR FRAME	1
2	ID1006	3/16 X 1 1/2 STAINLESS COTTER PIN	2
FGO127	FGO127	PLASTIC ROLLER	2
FGO128	FGO128	SHAFT	2

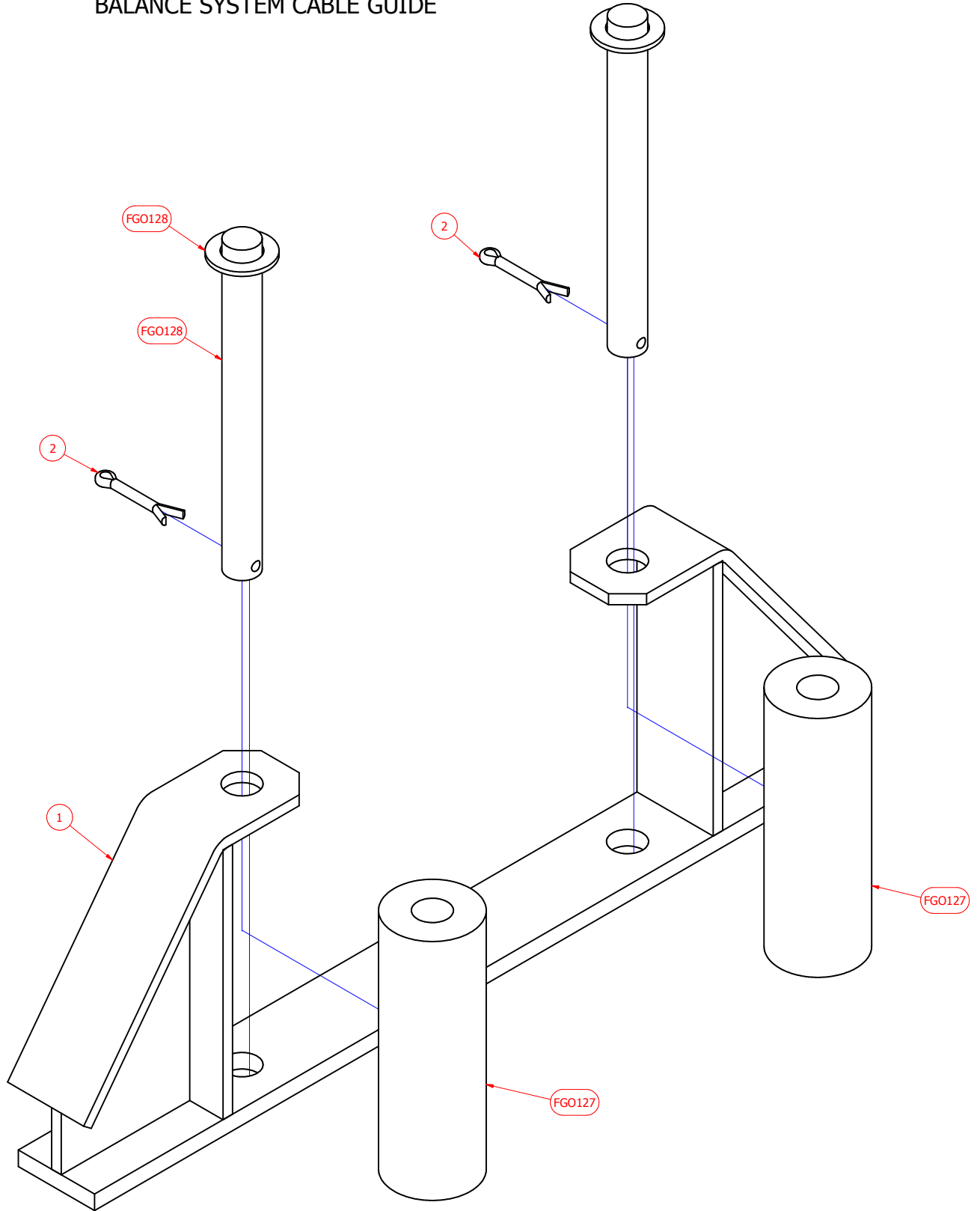

DRAWN	THenry	4/13/2010	IDEAL MFG., INC.	
CHECKED		1/12/2016	TITLE	
QA			BALANCE SYSTEM CABLE GUIDE	
MFG			SIZE	DWG NO
APPROVED			C	PSB M30B 109
			SCALE	REV
				1
				SHEET 1 OF 1

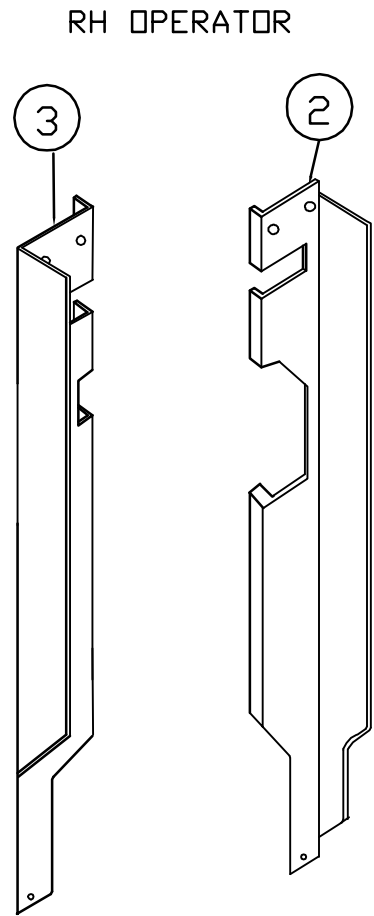
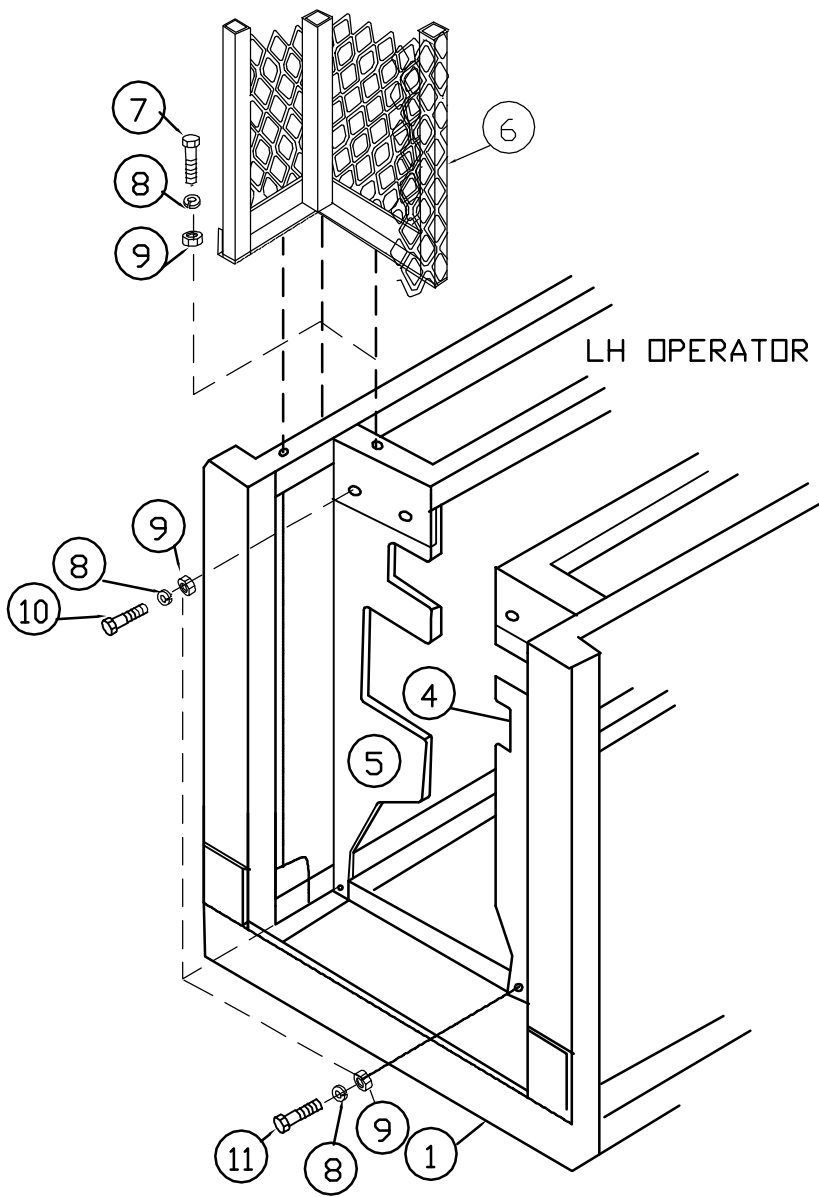

**TILT-A-WAY PATRIOT SECURITY BARRIER ACCESS GUARDS
MODEL PSB M30B**

REF NO.	PART NO.	DESCRIPTION	REQ NO
1	N/A	Operator Frame	1
2	FGO660	Left Inner Guard for Right Hand Gate	1
3	FGO661	Right Inner Guard for Right Hand Gate	1
4	FGO660A	Left Inner Guard for Left Hand Gate	1
5	FGO661A	Right Inner Guard for Left Hand Gate	1
6	FGO175	Outer Guard Aluminum Amplimesh	1
7	NA	3/8-16 X 2 3/4 Hex Head Bolt	2
8	N/A	3/8 Lock Washer	8
9	N/A	3/8-16 Hex Nut	8
10	N/A	3/8-16 X 3/4 Hex Head Bolt	4
11	N/A	3/8-16 X 1 1/2 Hex Head Bolt	2

**TILT-A-WAY
PATRIOT SECURITY BARRIER
BALANCE SYSTEM SPRING TENSIONER UNIT
DRAWING PSB M30B 111
(4 ASSEMBLIES INCLUDED)**

REF NO.	PART NO.	DESCRIPTION	REQ'D NO.
1	ID1061	Cotter Pin	4
2	N/A	1/2-13 X 3 Hex Head Bolt	4
3	N/A	1/2-13 Nylock Nut	4
4	N/A	10-24 X 1 1/2 Machine Screw	8
5	N/A	#10 Lock Washer	8
6	N/A	10-24 Hex Nut	8
7	N/A	Operator Frame	1
8		Front Spring Connector	4
	FGO168	500 or 1000 Pound Spring	1 per spring
	FGO170	1500 or 1750 Pound Spring	1 per spring
	FGO171	2000 or 2500 Pound Spring	1 per spring
9		Rear Spring Connector	4
	FGO139	500 or 1000 Pound Spring	1 per spring
	FGO157	1500 or 1750 Pound Spring	1 per spring
	FGO159	2000 or 2500 Pound Spring	1 per spring
10		Tension Spring	4
	TWO137	500 Pound	Blue
	TWO138	1000 Pound	Yellow
	TWO139	1500 Pound	Orange
	TWO112	1750 Pound	Green
	TWO140	2000 Pound	Red
	TWO113	2500 Pound	White
11	N/A	10 SAE Washer	8
FGO130	FGO130	Tension Screw with End Nut Welded	4
FGO131	FGO131	Safety Nut	4
FGO174	FGO174	Pipe Spacer	4
FGO403	FGO403	Safety Release Bar	4
FGO662	FGO662	Clevis Bracket	2
PEO611	PEO611	Safety Switch	4
PEO953	PEO952	Cable	2
PEO953	PEO953	Clevis	2
TWO104	TWO104	Clevis Pin	4
TWO108	TWO108	Set Screw	4
TWO133	TWO133	Safety Compression Spring	4

NOTE: WHEN ORDERING REAR SPRING CONNECTOR SPECIFIC FOR UPPER OR LOWER SPRING UNIT

TILT-A-WAY
MODEL PSB M30B
SPRING TENSIONER UNIT

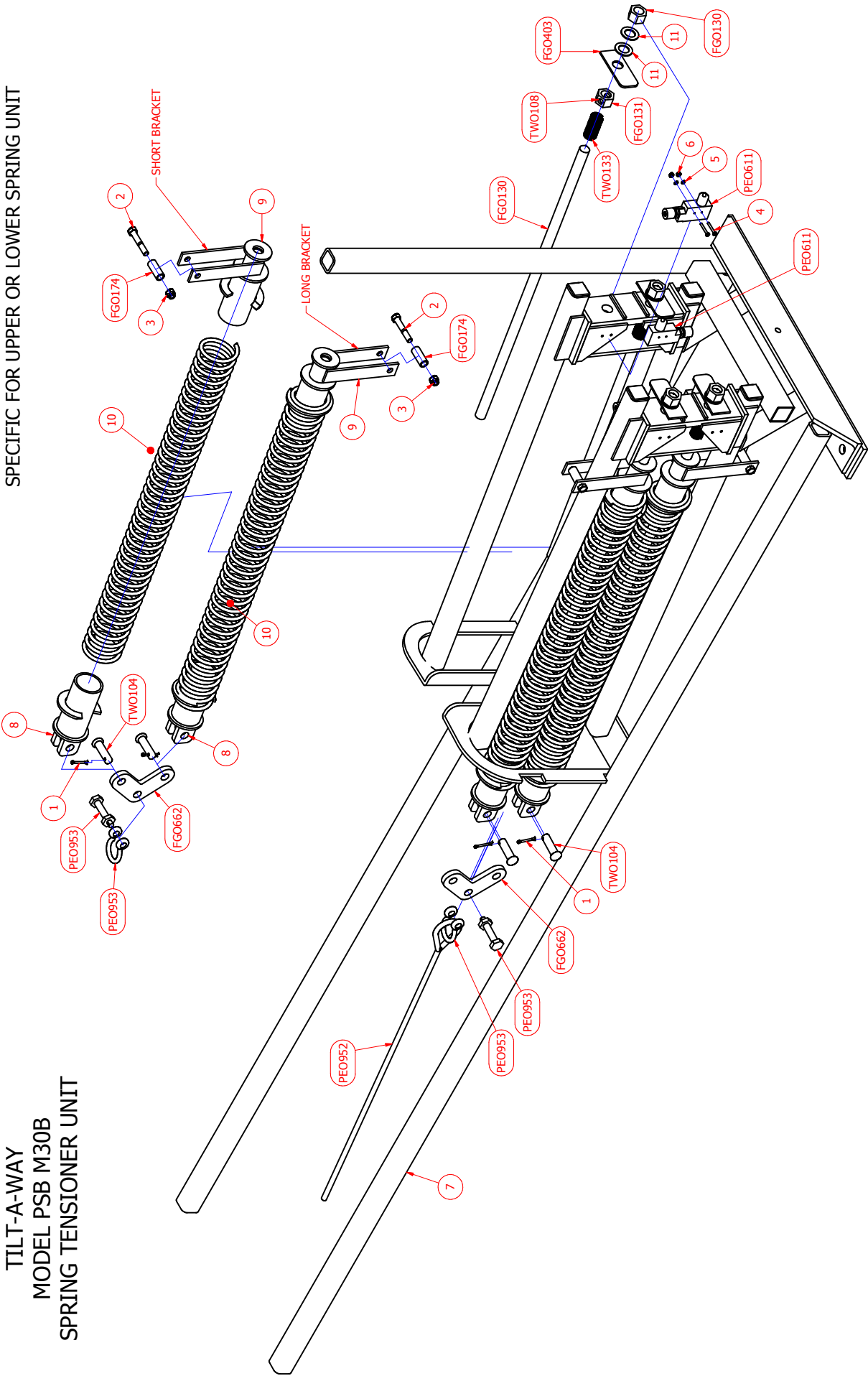

DRAWN		4/13/2010	TITLE		IDEAL MFG., INC.	
CHECKED		1/12/2016	TITLE		SPRING TENSIONER UNIT	
QA			SIZE	DWG NO	REV	
MFG			C	PSB M30B 111		
APPROVED			SCALE			
			SHEET 1 OF 1			

**TILT-A-WAY
PSB M30B
HYDRAULIC VERTICAL PIVOT GATE
HYDRAULIC SYSTEM**

DRAWING PSB M30B 112

REF NO.	PART NO.	DESCRIPTION	REQ'D NO.
1	TWO534	Hydraulic Cylinder	1
2	TWO410B	Hydraulic Pump & Reservoir Set Single Phase	1
3	TWO528	#8 MORB X #6 MJIC Adapter	1
4	TWO403	Extended Short 3/8 Pressure Hose 36ö	1
5	TWO165	Extended Long 3/8ö Pressure Hose 98ö	1
6	TWO578	90 Degree Elbow (short)	1
7	TWO579	90 Degree Elbow (long)	1
10		Manual Override Valves	2
11		Solenoid	1
12		Cylinder slow down open	1
13		Cylinder slow down closed	1
14		Sight Gauge	1
15		Directional Valves	2
16		Pressure Relief Valve (factory set at 450 psi)	1
17		In Tank Heater	1
18		Conduit	1
19		Conduit to Electrical Box	1

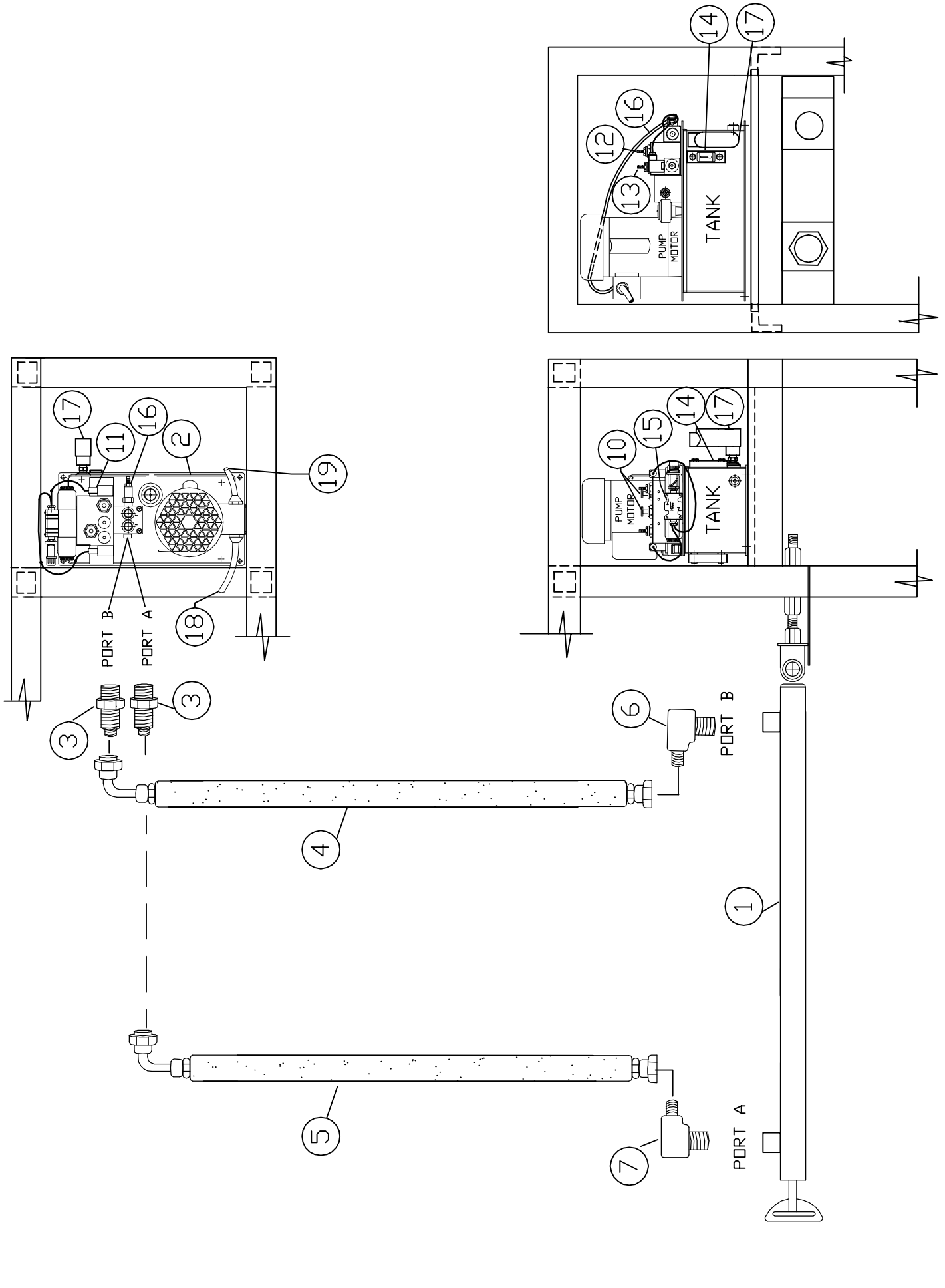

TILT-A-WAY PATRIOT SECURITY BARRIER EXTENDED HYDRAULIC SYSTEM
 MODEL PSB M30B

Parts List:	
PART NUMBER	DESCRIPTION
1	1/4-20 X 3/4 HEX BKT
2	1/4-20 X 2 3/4 HEX BOLT
3	1/4 LOCK WASHER
4	1/4 HEX NUT
5	#12 X 7/8 TEK SCREW
FGO203	REAR END CAP
FGO204	CABLE CONNECTION GUARD
FGO210	BARBED WIRE GUARD
FGO211	BARBED WIRE GUARD END BRACKET
FGO213	RIGHT HAND FLEXIBLE SHROUD UNIT EXTENDED
FGO663	FRONT ANGLE BRACKET
FGO664	CENTER ANGLE BRACKET
FGO665	REAR ANGLE BRACKET
TWO161	FRONT SPREADER CHAIN WITH EXTRA LENGTH FOR ADJUSTMENT
FGO204	WEATHER GUARD PACKAGE

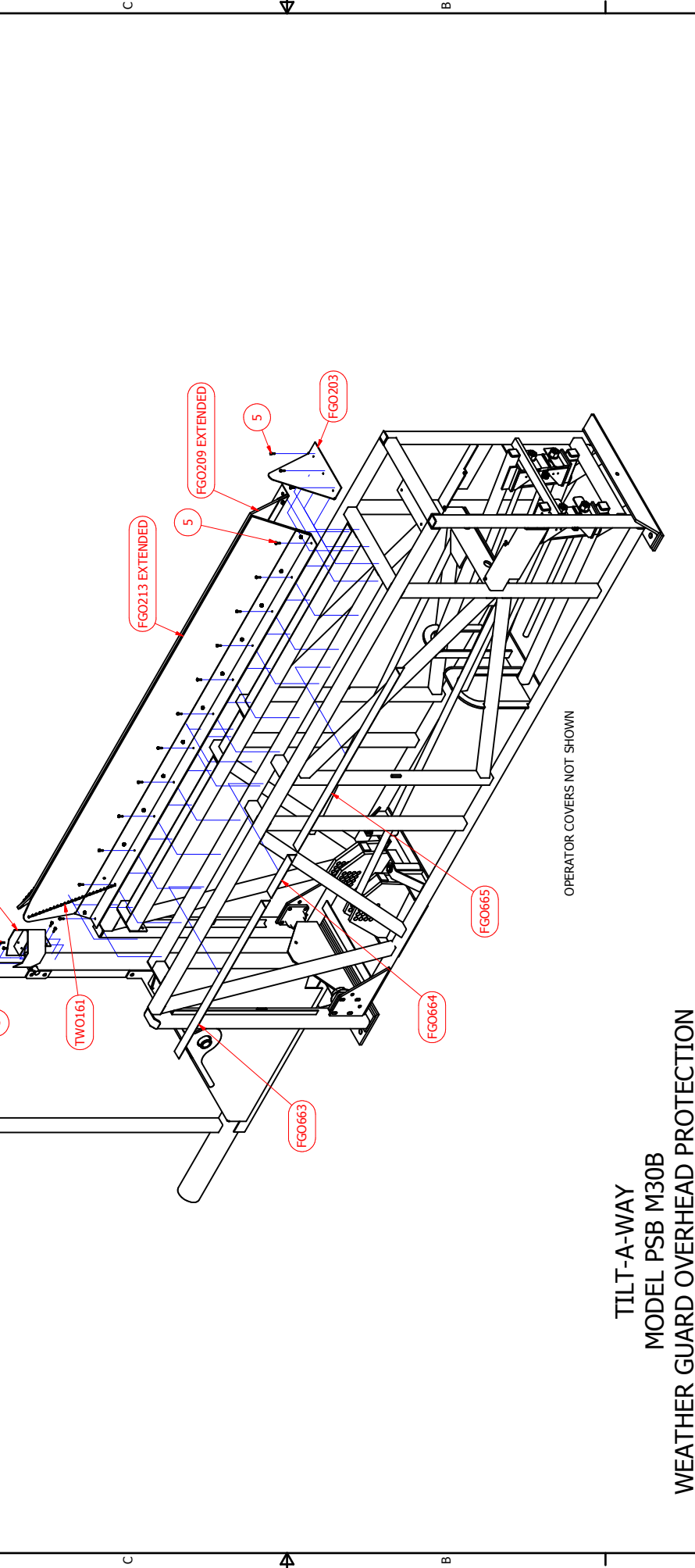

TILT-A-WAY
 MODEL PSB M30B
 WEATHER GUARD OVERHEAD PROTECTION

DRAWN	4/14/2010	TITLE	IDEAL MFG., INC.
CHECKED	1/12/2016		
QA			
MFG			PSB M30B WEATHER GUARDS
APPROVED			
		SIZE	DWG NO
		C	PSB M30B 113
		SCALE	
			SHEET 1 OF 1

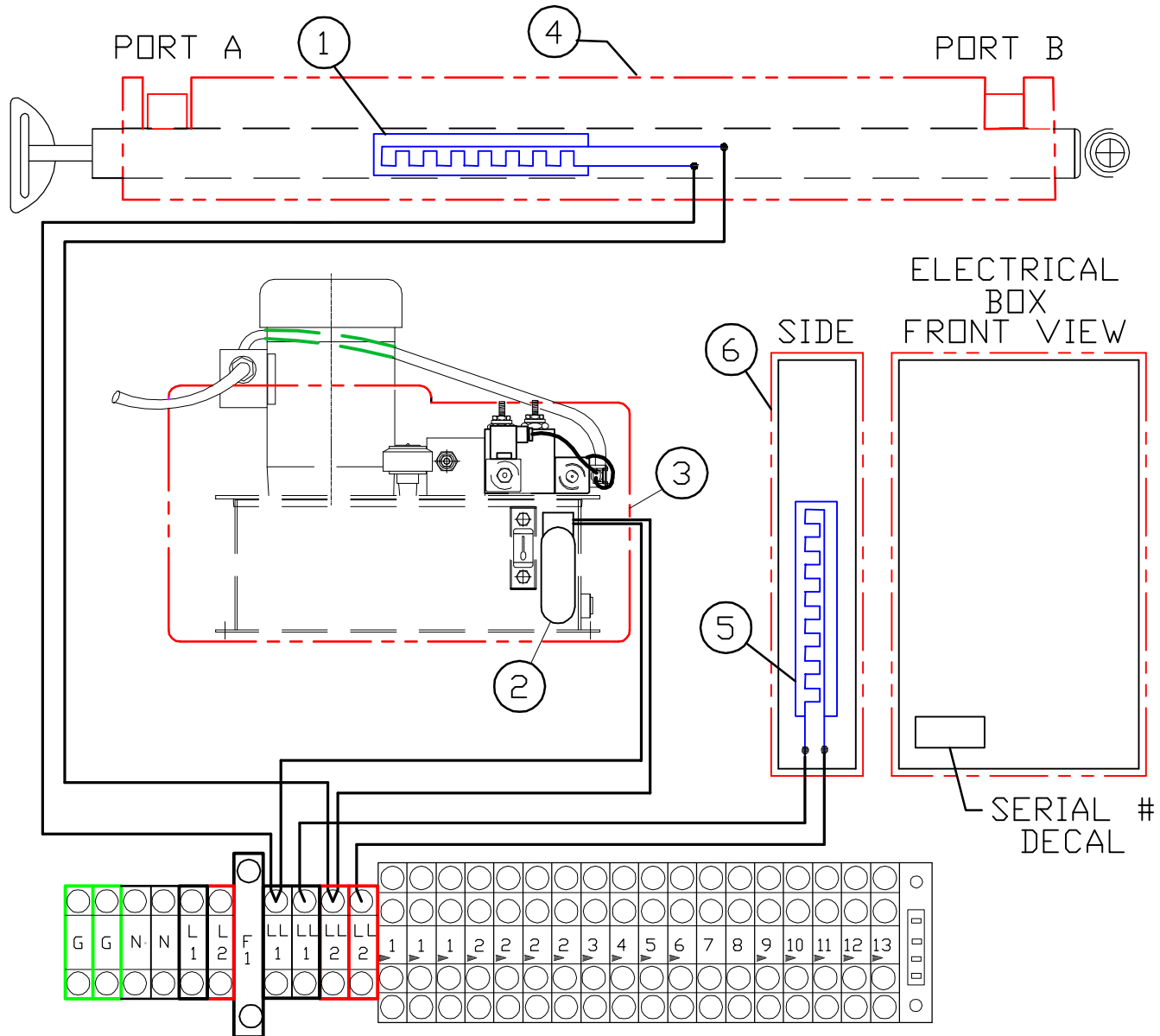

**TILT-A-WAY PATRIOT SECURITY BARRIER
MODEL PSB M30B
COLD WEATHER PACKAGE**

REF. NO.	PART NO.	DESCRIPTION	REQ. NO.
1	PEO247	Cylinder Heating Strip	1
2	PEO249	Pump Heating Strip	1
3	PEO420	Hydraulic Pump & Reservoir Insulating Cover	1
4	PEO421	Cylinder Insulating Cover	1
5	PEO252	Electrical Box Heating Strip	1
6	N/A	Electrical Box Insulating Cover	1

**TILT-A-WAY
MODEL PSB M30B
BILL OF MATERIALS POWER UNIT
4 GALLON POWER UNIT LAYOUT**

PART NO.	DESCRIPTION	REQ'D NO.
723629	Custom Reservoir	1
3004871-35	Hyco Sight Gauge	1
382069-4	Vickers Pump	1
3004827-25	Baldor Electric Motor	1
SP-02948-00	Filter Air Vent ¾ NPT	1
AD03P12S/C DO3 1 station	Damon Manifold W/Relief Cavity	1
02-113123/RV5-10-S-0-35/30	Vickers Relief Cartridge	1
02-145150/DG4V-3S-8C-VM-FW-B5-61	Vickers Control Valve	1
02-199679/MCD-8289	Custom Valve Assembly	1
02-178114	Custom Valve Coil	1
565542/SV4-10-00	Custom Valve Solenoid Valve Cartridge	1
02-113019/FCV7-10-S-0NVF	Custom Valve Slow Down Cartridge	2
565590/NV1-10-K-0	Custom Valve Emergency Open Cartridge	1

P & T PORT PLUGGED WITH STEEL PLUGS
 CUSTOMER A & B PORTS
 THIS SIDE OF BLOCK

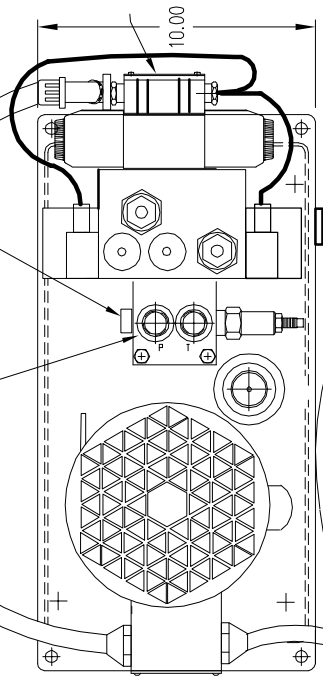

CONDUIT TO
 ELECTRICAL BOX

MOTOR SHOWN
 2HP 110/220/1/60

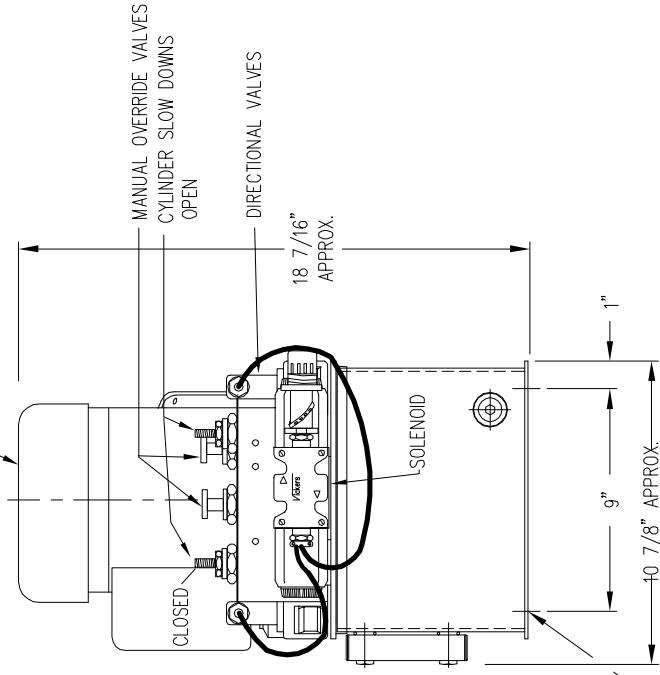

MOUNTING HOLES
 7/16" DIA. THRU TYP. 4

SIGHT GAUGE
 OIL LEVEL TO
 BLACK LINE WHEN
 BARRIER IS IN "Up"
 POSITION

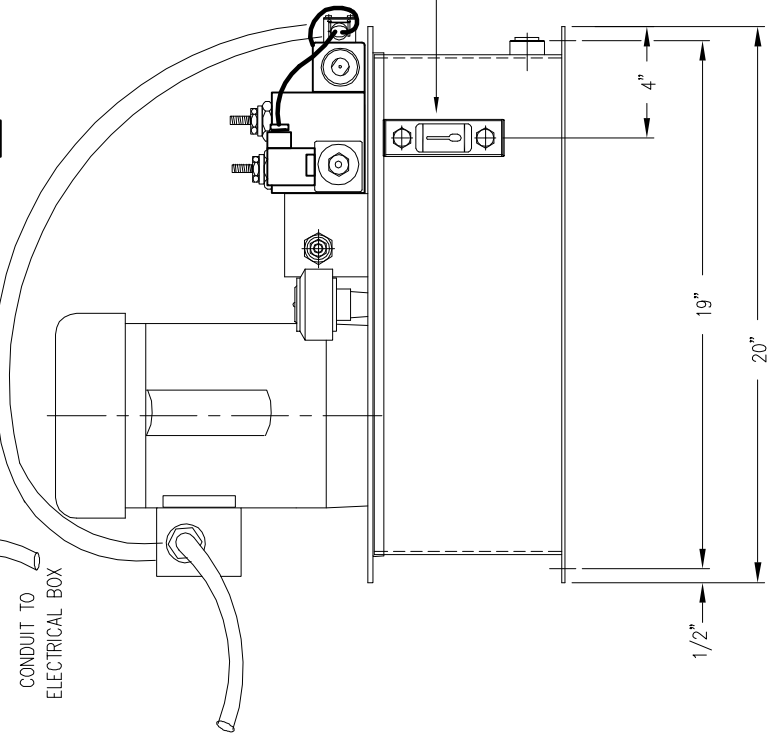

VICKERS 4 GALLON POWER UNIT LAYOUT

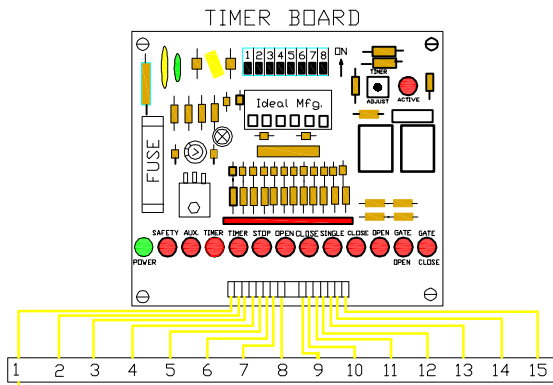

WHEN THE EMERGENCY STOP
HAS BEEN ACTIVATED
THE POWER MUST BE TURNED OFF
AND THEN BACK ON FOR THE
GATE TO RETURN TO NORMAL OPERATION.
USE THE BREAKER SWITCH ON
THE SIDE OF THE ELECTRICAL ENCLOSURE.

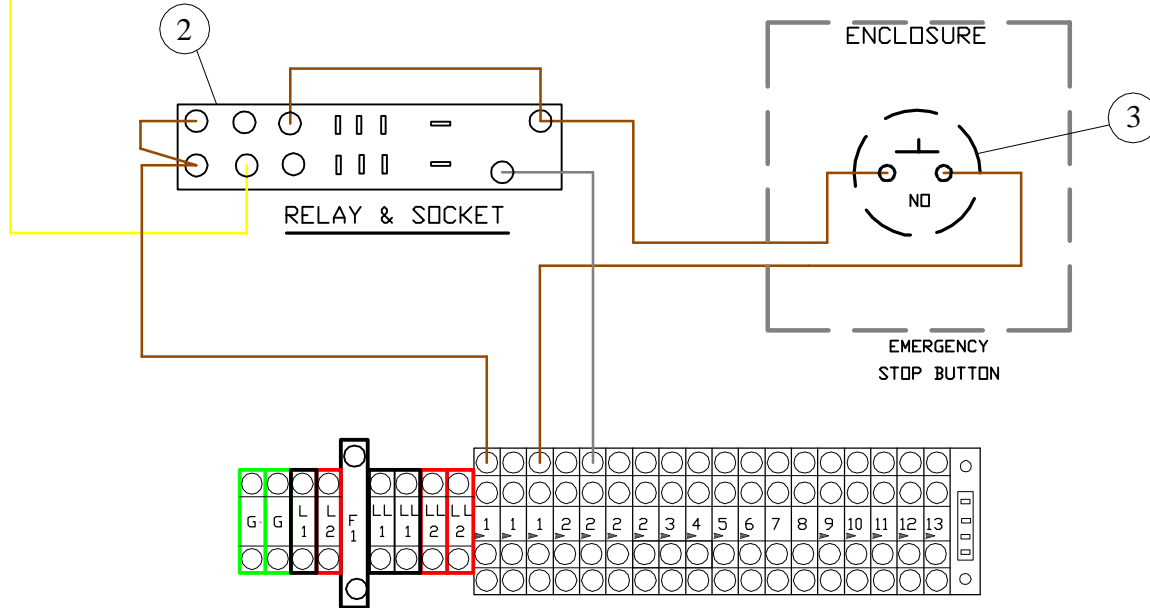

T.B. LOCATED IN
MAIN ENCLOSURE

TILT-A-WAY PATRIOT SECURITY BARRIER MODEL PSB M30B EMERGENCY STOP COMPONENTS

REF. NO.	PART NO.	DESCRIPTION	REQ. NO.
1	PEO606	Relay (not shown)	1
2	PEO606A	Socket, Relay	1
3	PEO407	Emergency Stop Button	1

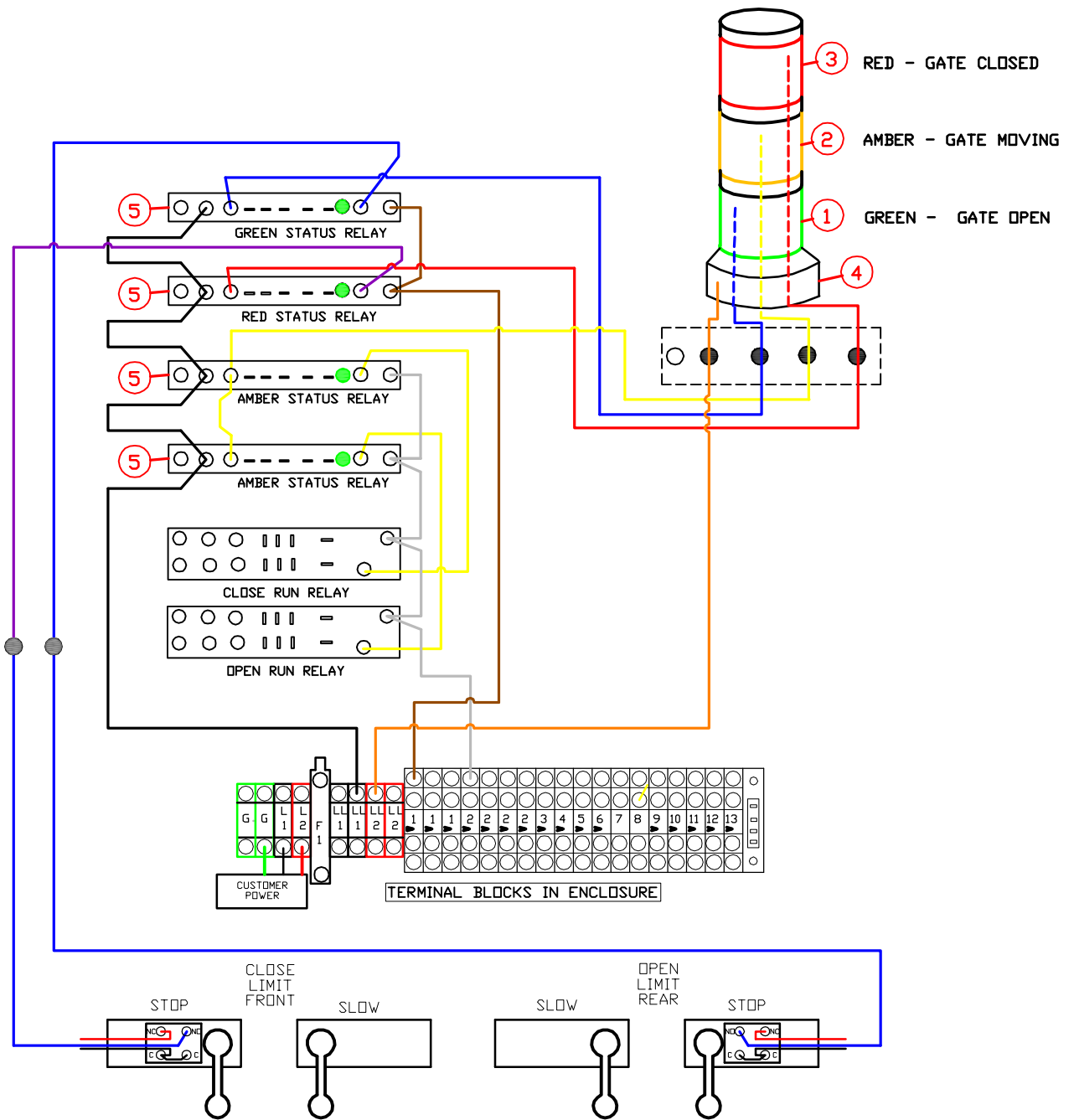

**TILT-A-WAY PATRIOT SECURITY BARRIER
PSB M30B
208 / 240 VAC SINGLE PHASE
SAFETY WARNING LIGHT & SECURITY RELAYS**

REF. NO.	PART NO.	DESCRIPTION	REQ. NO.
1	PEO361-2	Light Module - Green - Steady 240 VAC	1
2	PEO362-2	Light Module - Amber - Steady 240 VAC	1
3	PEO363-2	Light Module - Red - Steady 240 VAC	1
4	PEO360	Pole Mount Base	
5	PEO639	Relay & Socket	4
	PEO364-2	Single Tone Sound Module (not shown) (Optional) 240 VAC	
	PEO365-2	Incandescent Lamp (not shown) (replacement) 240 VAC	

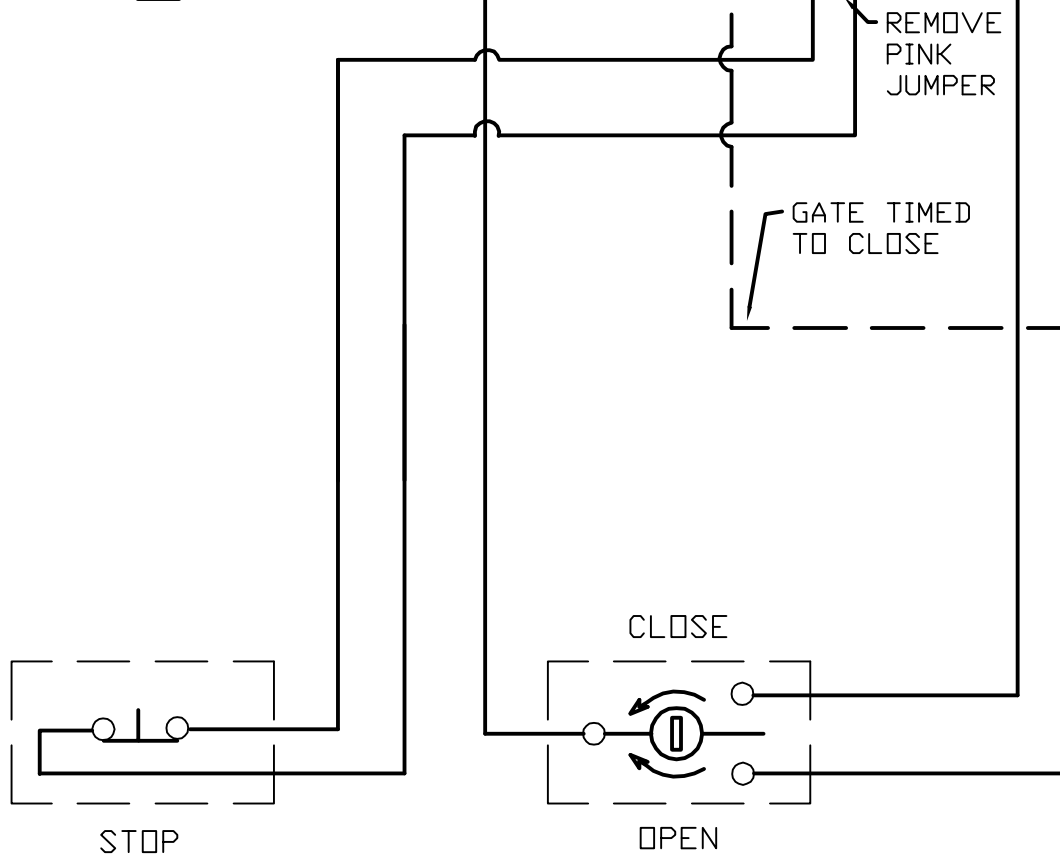
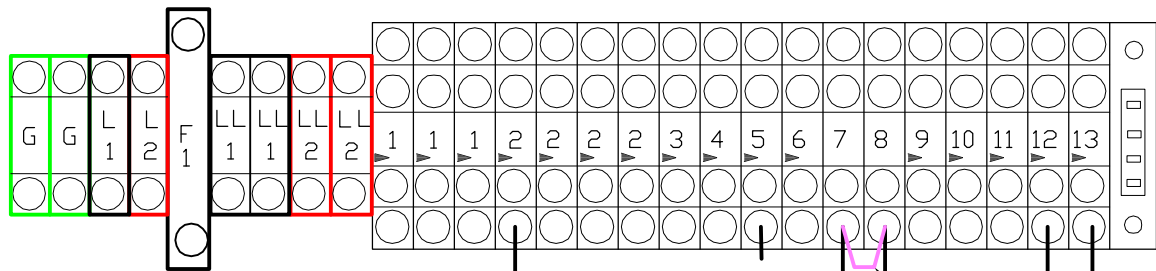

STOP P.B.
IF OTHER PUSH BUTTON
STATIONS ARE BEING USED,
WIRE IN SERIES

TILT-A-WAY PATRIOT SECURITY BARRIER
MODEL PSB M30B
MANUAL KEY SWITCH

PART NO	DESCRIPTION	REQ NO
PEO263	Manual Key Switch	as req'd

**TILT-A-WAY
MODEL PSB M30B**
LEFT HAND OPERATOR SHOWN

Parts List		
PART NUMBER	QTY	DESCRIPTION
FGO403	1	ACCESS DOOR
FGO420	2	REAR TOP COVER
FGO421	2	FRONT TOP COVER
FGO422	2	EXTENDED TOP COVER
FGO423	1	END TOP COVER
FGO424	2	REAR SIDE COVER (1 WITH SNOW DOOR OPTION)
FGO424MR	2	FRONT SIDE COVER (1 WITH SNOW DOOR OPTION) FGO424MR FOR LEFT HAND OPERATOR FGO424ML FOR RIGHT HAND OPERATOR
FGO425	2	END SIDE COVER
FGO426	2	EXTENDED SIDE COVER
FGO643	1	STANDARD SNOW DOOR (OPTIONAL)
FGO644L	1	PSB M50 SNOW DOOR (OPTIONAL) FGO644L FOR LEFT HAND OPERATOR FGO644R FOR RIGHT HAND OPERATOR

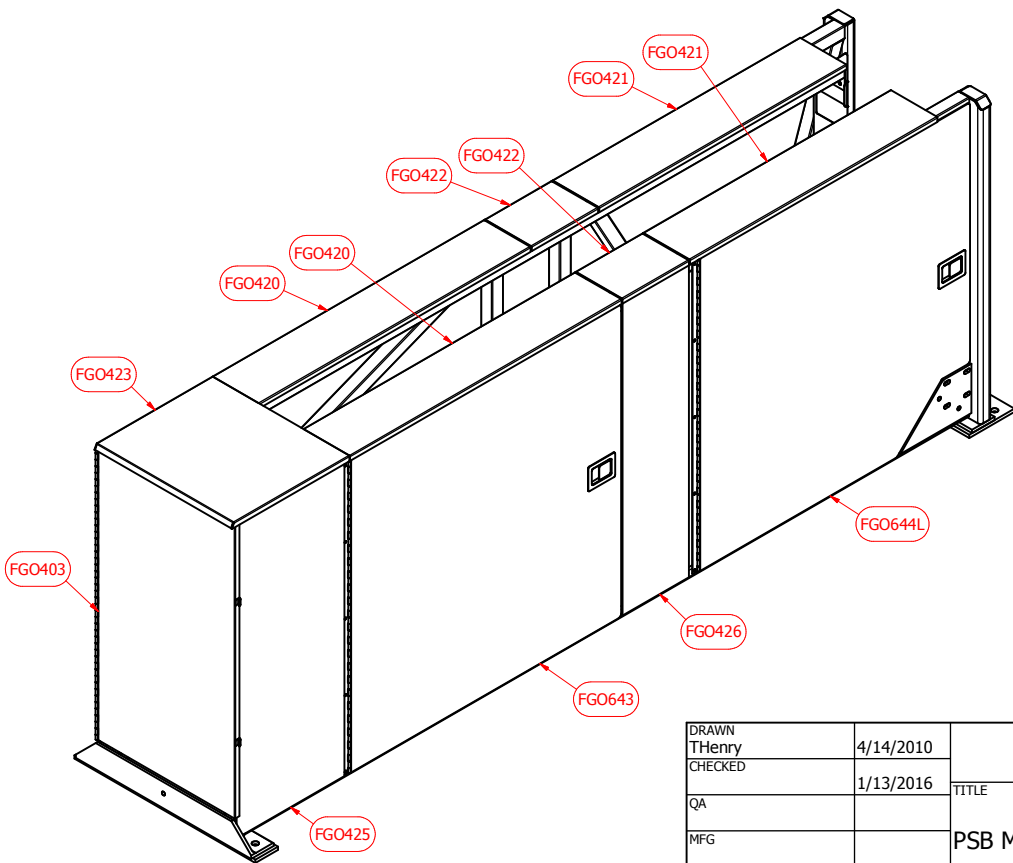
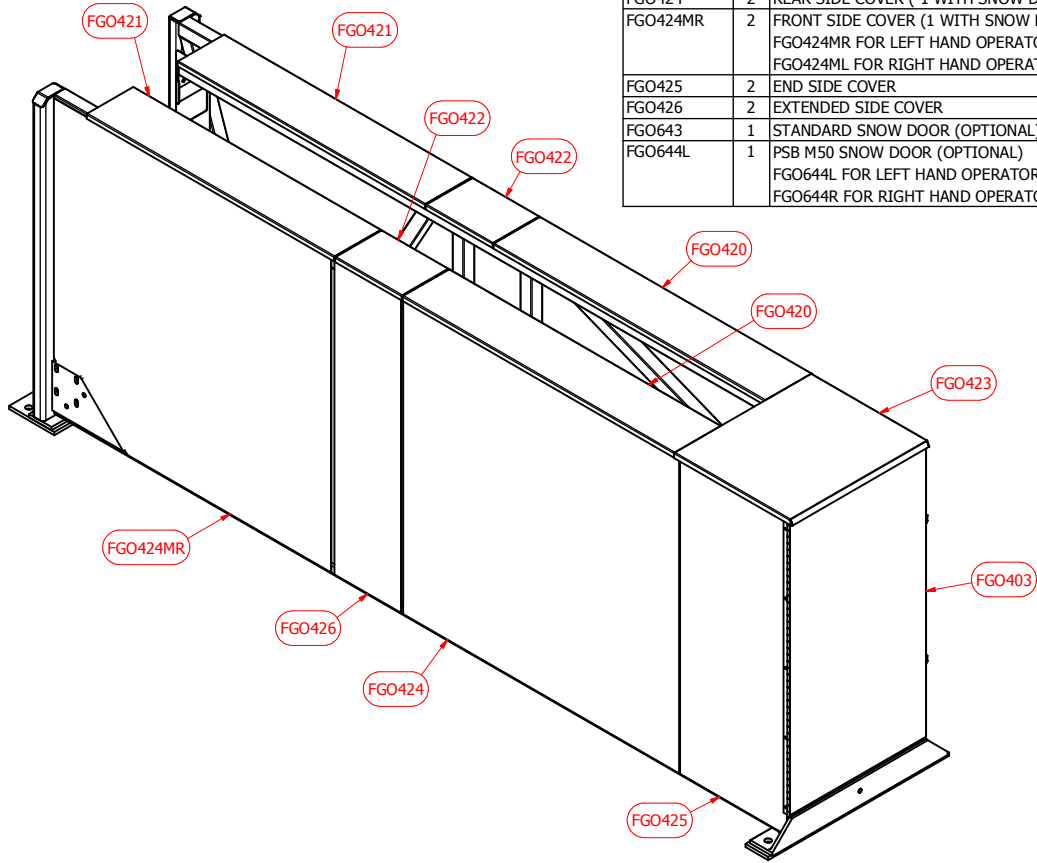

DRAWN	THenry	4/14/2010	IDEAL MFG., INC.		
CHECKED		1/13/2016	TITLE		
QA			PSB M30B COVERS		
MFG			SIZE	DWG NO	REV
APPROVED			C	PSB M30B 119	
			SCALE	SHEET 1 OF 1	

TIMER BOARD

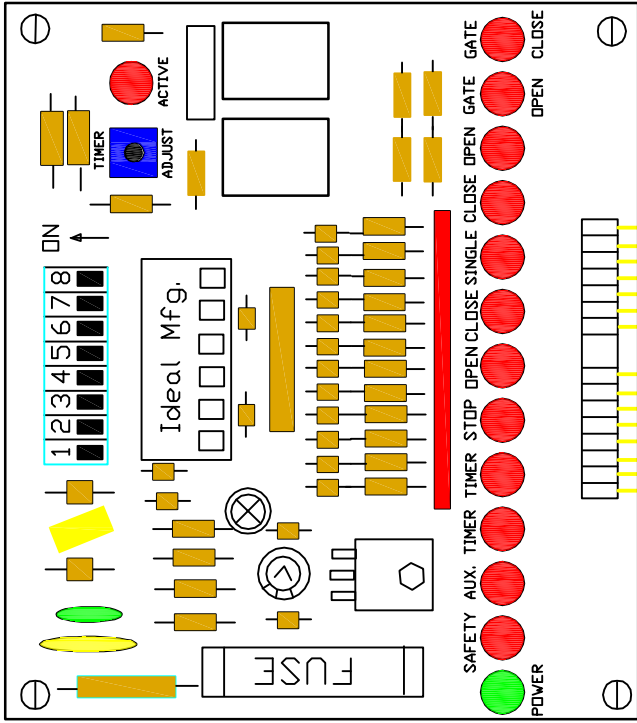

NOTE:
 WIRES NUMBER
 14, 15
 CONNECT TO RELAYS
 SEE DWG# PSB M50A-200
 PAGE 7

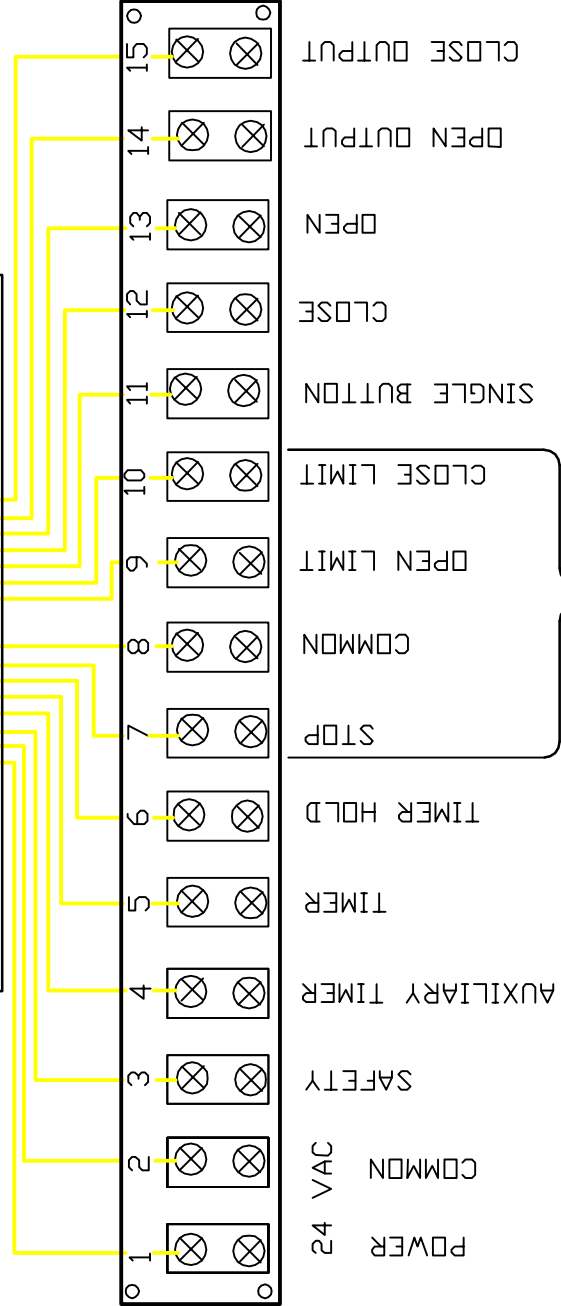

IDEAL MANUFACTURING INC.
TILT-A-WAY ROAD GATE
ELECTRICAL LOGIC TIMER BOARD
PAC
ACAD
PSB M30B 120
DATE: 1-12-2016

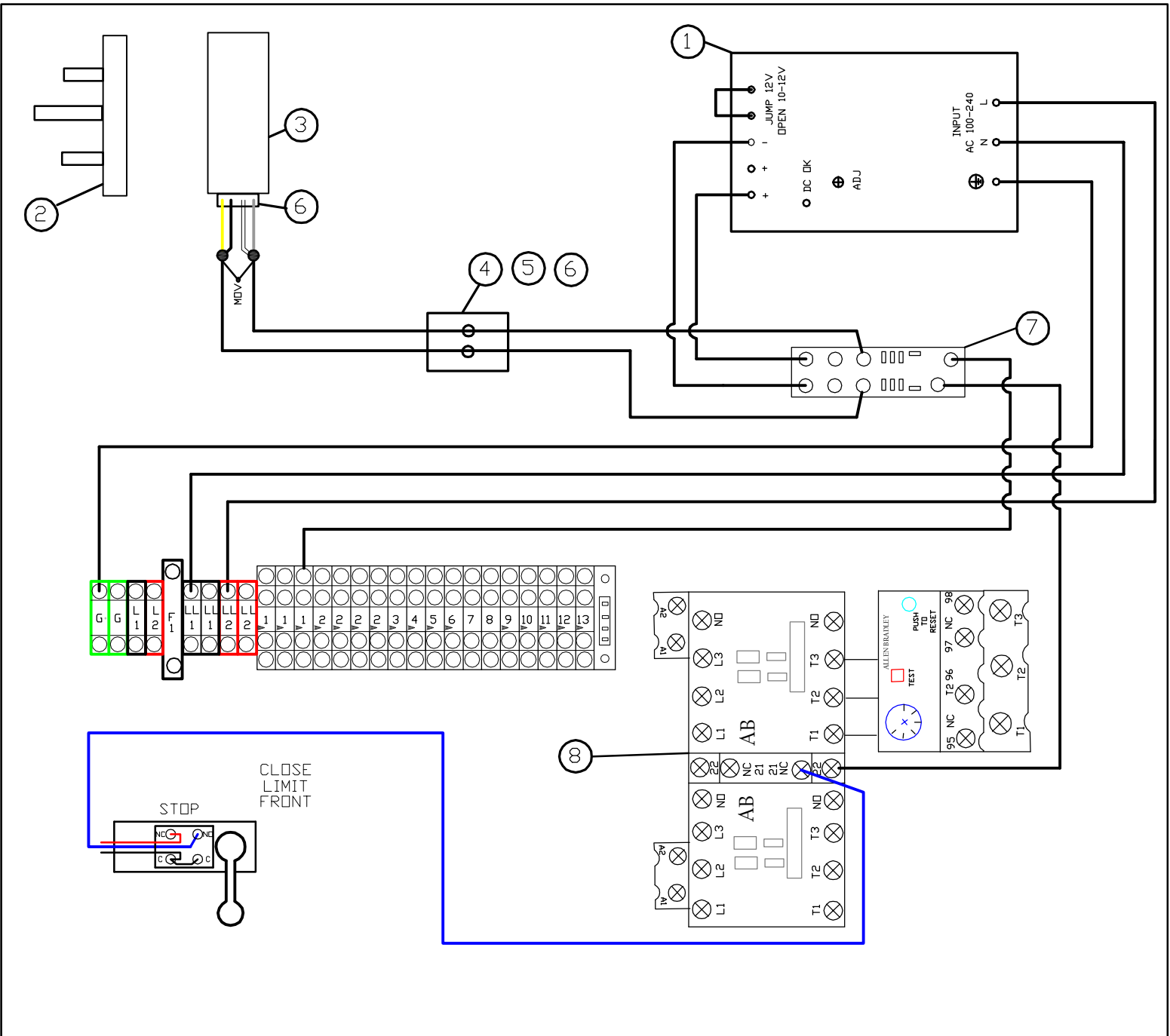

TILT-A-WAY PATRIOT SECURITY BARRIER
PSB M30B
ELECTROMAGNETIC LOCK
208 / 240 VAC SINGLE PHASE

REF NO.	PART NO.	DESCRIPTION	REQ NO
1	PEO276	240 VAC to 12 VDC Converter (Located in Electrical Enclosure)	1
2	PEO277-1	Electromagnetic Armature (Located stationary at outer end of barrier or at outer end of an opposite barrier)	1
3	PEO277-1	Electromagnetic Lock (Located at outer end of barrier)	1
4	PEO278	Junction Box (Located inside front of pedestal frame)	1
5	PEO237	Junction Box Cover	1
6	PEO246	1/2" Strain Relief Fitting (one at barrier lower pipe)	4
7	PEO606A	Relay Socket (Located in Electrical Enclosure)	1
	PEO606	Relay (not shown) (Located in Electrical Enclosure)	1
8	PEO603	Reversing Controller (Located in Electrical Enclosure)	N/A

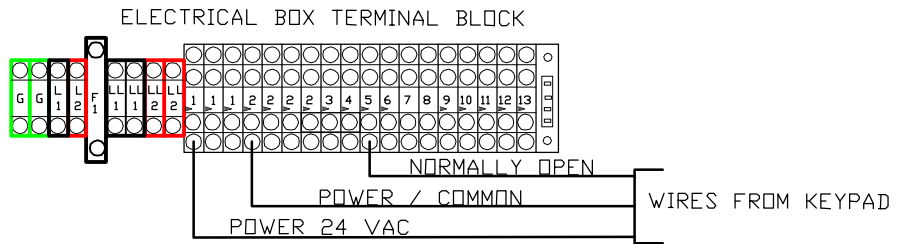
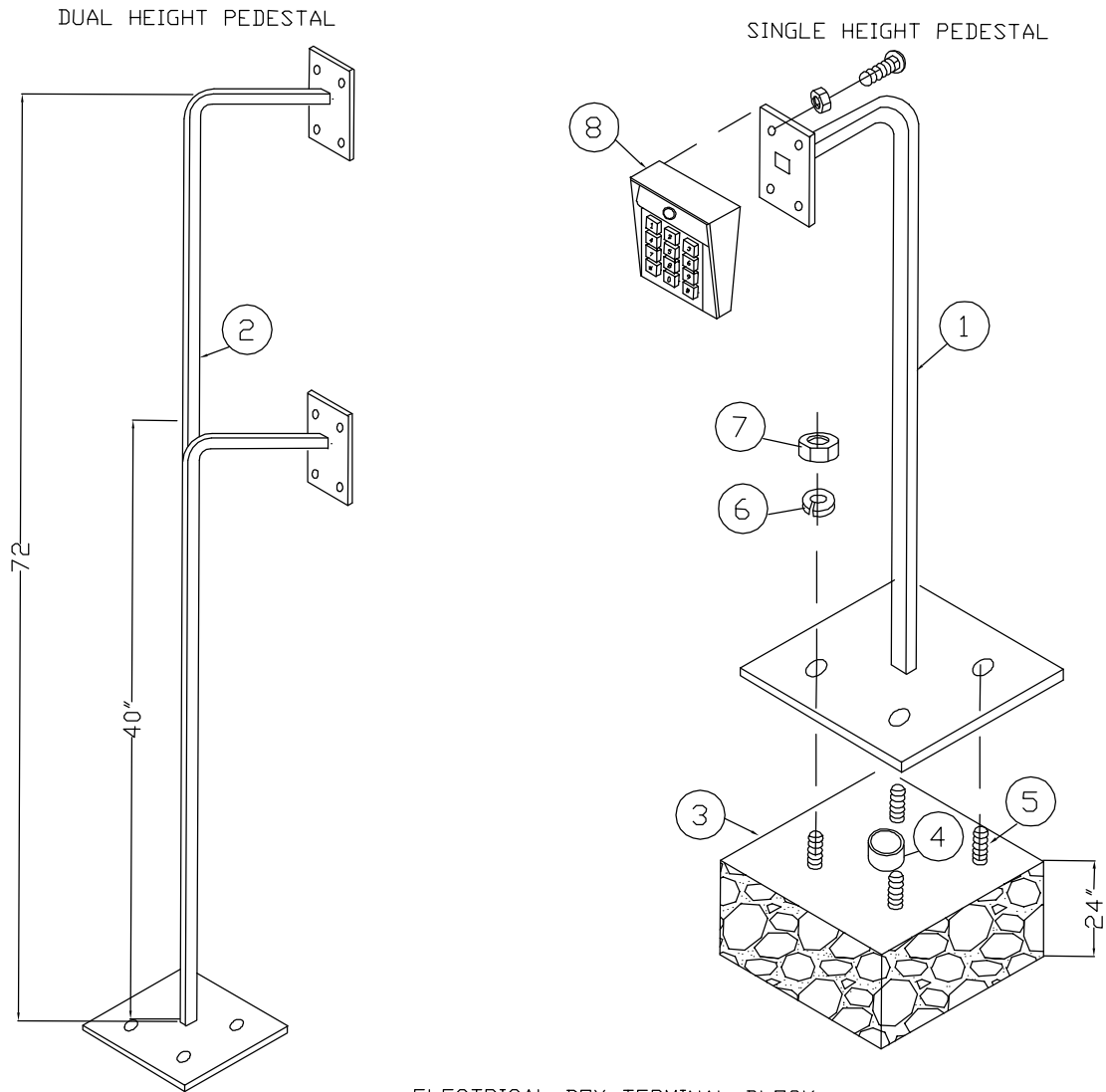

**TILT-A-WAY PATRIOT SECURITY BARRIER
MODEL PSB M30B
REMOTE CONTROL STATION PEDESTAL AND GATE LOCK**

REF NO.	PART NO.	DESCRIPTION	REQ NO
1	N/A	Single Height Pedestal	1
2	N/A	Dual Height Pedestal 72" in Height	1
3	N/A	Concrete Support Pier 15" X 15" X 24" Deep	1
4	N/A	1" in Diameter Electrical Conduit with 2 1/2" projection above Concrete. Conduit Routed from Barrier Pedestal.	1
5	N/A	1/2" x 8" Expansion Bolt	4
6	NA	1/2" Lock Washer	4
7	N/A	1/2" Hex Nut	4
8	N/A	Remote Control Station of Choice (Included are bolts, nuts, keys and plate.	4

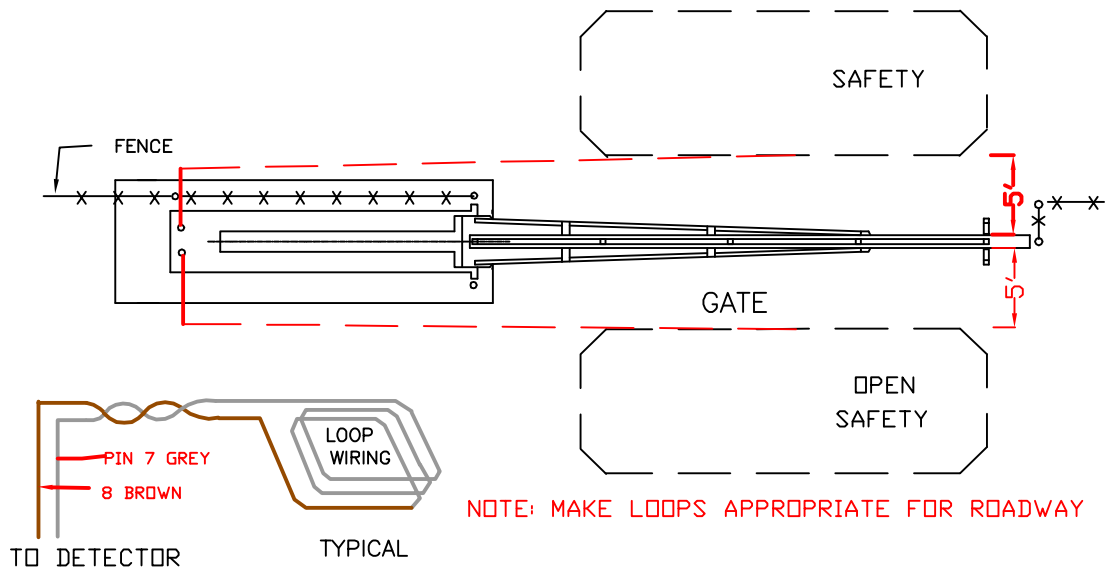

OPEN SAFETY

LOOP DETECTOR	PIN 1 BROWN	2 GREY	4 GREEN	5 GREY	6 BLUE
TERMINAL BLOCK	1	2	BOX GROUND	2	5

SAFETY

LOOP DETECTOR	PIN 1 BROWN	2 GREY	4 GREEN	5 GREY	6 ORANGE
TERMINAL BLOCK	1	2	BOX GROUND	2	3

NOTE:

Lead wires from more than one loop installation may be routed in same conduit if wires from each individual loop are twisted at least 6 turns per 12 inches.

NOTE: Loop to open gate, pin-6 Blue

Terminal - 13 OR 5 FOR TIME TO CLOSE

Loop to close gate, pin-6 Purple

Terminal - 12

TILT-A-WAY PATRIOT SECURITY BARRIER
MODEL PSB M30B

ELECTRICAL LOOP WIRING

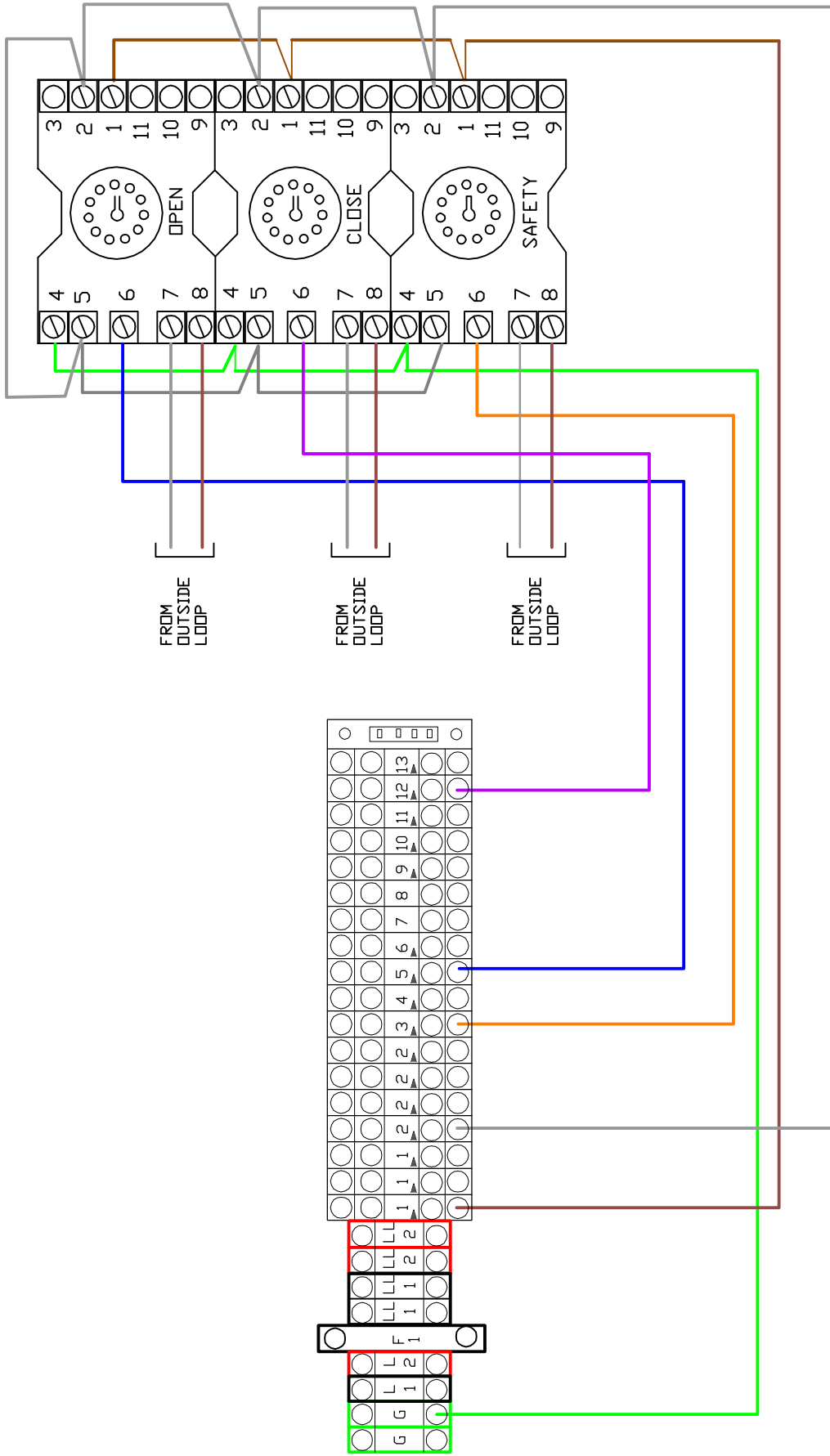

**TILT-A-WAY PATRIOT SECURITY BARRIER
MODEL PSB M30B
LOPP DETECTOR DIAGRAM**

TO: **Loop Detector Installers**
FROM: Joe Rozgonyi
DATE: July 15, 1996
SUBJECT: **Loop Wires Installation**

Dear Installer:

You may have installed loops for some time. Or, you may be just starting out. In any case, it is good to refresh our memory and maybe learn some new tricks.

First, remember that the loop is an integral part of the detector electronic circuitry. We, the loop detector manufacturers entrust you with making a very important electronic part of our loop detector.

Materials used in the construction of the loop are important. The loop wire should be 16 gage stranded tinned copper wire with cross-linked polyethylene (XLPE) insulation rated for 600V. By using this wire you get the following **advantages**:

- a. The wire gage is large enough so the serial resistance of the loop is low.
- b. The wire is flexible enough to work with in the saw cut, minimizing the possibility of a damage to the insulation.
- c. The XLPE insulation has increased moisture and solvent resistance, and superb aging characteristics. Moisture and solvents in the black top pavement or oil spills from the cars are the major causes in long term insulation damage that causes **intermittent loop lockups and false detection**.

Note: The standard THHN wire so popular with installers is designed for the following applications:

" An all around general purpose building wire, for fixture raceways, conduit and tubing raceways, internal wiring of fixtures and applications requiring building wire".

Please note that the THHN wire was designed for conduit application. It sometimes has a very thin sheeting of nylon, which protects it from moisture, but it is easily damaged during wire installation in the saw cut.

Sealant: Use only a commercial type of loop sealant designed for traffic loops. Any other material will not work for a long time.

Backer Rod: Use a backer rod to ensure that the wires are in place and do not vibrate under the backer rod. Any vibration or wire movement will cause a false detection.

We have the materials covered so let's discuss the **wire installation**. The purpose of all the installation rules you may have heard or read is very simple. We want you to construct a wire coil in the pavement that will comply with the following:

- a. The loop wire insulation will be intact for a long time after you have sealed it in the pavement.
- b. The loop wire will not move or vibrate in the pavement.
- c. The loop wire will be away from any electrical noise.
- d. The loop wire will be away from any moving metal you do not want to detect.
- e. The loop wire continuity (or serial resistance) will be low and constant.

Let's expand on these five points:

a. The wire insulation is very important in preventing a false detection and detector lock-ups. So any scratches on the wire insulation, sharp edges in the saw cut, or small stones in the saw cut and sharp tools used during the installation will cause damage to the wire.

Good Insulation = No Call Back

b. Any vibration of the loop wires or the movement of the steel mesh underneath of the loop will cause false detection. Before the loop installation, inspect the pavement. If in the area of the loop you see large cracks in the pavement and there is an evidence of pavement movement, there is a potential problem. Parts of the pavement may move after you have installed the loops and damage the wire, or cause false detection. Use the backer rod to make sure that the wire is held firm in the saw cut.

No Wire Vibration and Good Pavement = No Call Back

c. If you have a power line running under the loop wire do not be surprised if you get false detects. The changes in electrical current are detected by the loop detector as cars.

No Power Lines Close To The Loop = No Call Back

d. If you have a metal slide gate or a metal overhead door close to the loop, the detector will detect it. The detector cannot distinguish between the metal in the gate and the metal in the car.

No Moving Metal Close To The Loop = No Call Back

e. Wire nut as a splice connection is great when dealing with mains. However, when you have to make a splice on the lead-in wire use a solder iron. The current on the loop wire is too low to overcome the long term oxidation occurring on a wire nut connection.

Soldered Splices = No Call Back

In summary

The following elements can reduce the loop detector sensitivity:

1. Underground steel reinforcing - make the loop cut shallow in concrete pavement (approx. 1 inch) or use fiberglass mesh when installing new concrete pavement.
- 2 More than one loop connected to one detector - if you are experiencing a low sensitivity problem and you have two loops on one detector, consider adding an additional loop detector. Two loops on one detector = half of the sensitivity.

The following elements can cause detector lock up or intermittent detection:

1. Cross-talk between adjacent loops due to both having the same operating frequency. Use the LD-2000 loop detector frequency counter feature to measure the loop frequency.
2. Inadequate loop spacing - keep loops 4 feet apart.
3. Loop wire vibration in the saw cut - use backer rod.
4. Splices with wire nut - solder all splices
5. Lead-in wires not twisted - twist lead-in wire at least 6 turns per foot.
6. Power lines close to the loop - keep at least 6 feet away from power lines.
7. Loop too close to moving gate - keep at least 4 feet way.

Note: Always connect safety loops in series, free exit loops can be connected in parallel.

Use automatic sensitivity boost to detect high bed vehicles.

Use the filter function to filter out RF noise generated by police and EMS vehicles.

Use fail safe detector for safety and fail secure detector for free exit application.

Shortcut: You can avoid installation problems and guess work by simply installing a well constructed preformed loop like our EMX Lite Loop.

Loop Sizes and Loop Characteristics

Loop Size	Loop Size	Inductance	Turns	Detect. Height
2	2	60	5	1.6
2	4	60	4	1.6
2	6	80	4	1.6
2	8	60	3	1.6
2	10	72	3	1.6
2	12	84	3	1.6
2	14	96	3	1.6
2	16	108	3	1.6
2	18	120	3	1.6
2	20	132	3	1.6
4	4	80	4	3.2
4	6	100	4	3.2
4	8	72	3	3.2
4	10	84	3	3.2
4	12	96	3	3.2
4	14	108	3	3.2
4	16	120	3	3.2
4	18	132	3	3.2
4	20	144	3	3.2
4	22	156	3	3.2
4	24	168	3	3.2
4	26	180	3	3.2
4	28	192	3	3.2
4	30	102	2	3.2
4	32	108	2	3.2
4	33	111	2	3.2
4	34	114	2	3.2
4	36	120	2	3.2
4	38	126	2	3.2
4	40	132	2	3.2
6	6	120	4	4.8
6	8	84	3	4.8
6	10	96	3	4.8
6	12	108	3	4.8
6	14	120	3	4.8
6	16	132	3	4.8
6	18	144	3	4.8

All the numbers are approximated, actual results may vary.

Loop Sizes and Loop Characteristics

Loop Size	Loop Size	Inductance	Turns	Detection Hight
6	20	78	2	4.8
6	22	84	2	4.8
6	24	90	2	4.8
6	26	96	2	4.8
6	28	102	2	4.8
6	30	108	2	4.8
6	32	114	2	4.8
6	33	117	2	4.8
6	34	120	2	4.8
6	36	126	2	4.8
6	38	132	2	4.8
6	40	138	2	4.8
8	4	120	4	3.2
8	6	140	4	4.8
8	8	96	3	5.6
8	10	108	3	5.6
8	12	120	3	5.6
8	14	132	3	5.6
8	16	144	3	5.6
8	18	78	2	5.6
8	20	84	2	5.6
8	22	90	2	5.6
8	24	96	2	5.6
8	26	102	2	5.6
8	28	108	2	5.6
8	30	114	2	5.6
8	32	120	2	5.6
8	33	123	2	5.6
8	34	126	2	5.6
8	36	132	2	5.6
8	38	138	2	5.6
8	40	144	2	5.6
Loop Numbers				
Serial Resistance: between two lead-in wires - less than 5 ohms				
Leakage to Ground: between one lead-in wire and the ground more than 10 mega ohm at 500VDC for one minute.				
Use DI 6200 insulation tester or equivalent				

All the numbers are approximated, actual results may vary.

D-TEK Vehicle Loop Detector - Operating Instructions

We at EMX have designed the new D-TEK vehicle loop detector with the following objectives in mind:

1. Compact package to allow easy installation into small operator housings.
2. All the controls are accessible from the outside for easy installation and operation.
3. Integral loop conditioner is provided, to enable detector operation with marginal loops.
4. Provide all the features and controls necessary for a variety of applications.
5. Use metal housing for maximum durability and RF blocking.
6. Provide maximum surge protection on all inputs and outputs of the detector.

We took extra care to achieve and exceed these objectives. For example the controls are divided into two groups. The group on the front of the detector is for basic operation and the group on the back of the detector is for advanced settings. This way the more advanced settings are not visible to the casual user.

There is no skimping on the quality in the D-TEK detector. The housing is made from aircraft quality anodized aluminum. All the switches have gold plated contacts and are sealed for protection. The detector is protected by easily replaceable fuse, snubbing circuitry on the relay contacts, metal oxide varistor on the power input and triple protection on the loop input.

The D-TEK features are extensive and they include full loop diagnostics with frequency counter, 10 sensitivity settings, delay and extend features, "fail safe" and "fail secure" operation, automatic sensitivity boost, pulse or two presence relay operation and more.

Technical Information

Detector Connections

Pin	Function	Harness
1	Power	White
2	Power	Black
3	Relay 2 N.O	Orange
4	Ground	Green
5	Presence Relay Comm..	Yellow
6	Presence Relay N.O.	Blue
7	Loop	Gray
8	Loop	Brown
9	Relay 2 Comm..	Red
10	Presence Relay N.C.	White/Blk or Pink
11	Relay 2 N.C.	White/Red or Violet

Note: Functions on pins 6 and 10 are reversed if DIP 4 is set to **OFF** "Fail Secure" operation

Front Indicators

1. Green Led is ON - the detector is powered.
2. Red Led is ON - the detector detected a vehicle
3. Green Led is Blinking - the loop failed and is shorted or disconnected
4. Green Led is Blinking with two consecutive fast blinks - the loop failed in the past and now is working correctly.
5. Red Led is Blinking at the start of a vehicle detection - the Filter function is ON
6. Red Led is Blinking at the end of a vehicle detection - the Extend function is ON
7. Red Led is Blinking during a vehicle detection - 4 minute limited presence time has expired.

Note: Functions on pins 6 and 10 are reversed if DIP 4 is set to OFF

Front Controls

- Reset this toggle switch when pushed momentarily down will reset the detector
- Frequency Counter this toggle switch when pushed momentarily up will count the frequency on the loop. This count is displayed by the Red Led blinks, each blink represents frequency of 10K Hz. Count between 3 to 13 blinks confirms that the loop detector is tuned to the loop.
- Frequency This toggle switch controls the loop frequency. Set different frequencies on adjacent loops. Verify frequencies with the frequency counter by counting the Red Led blinks.

Back Controls

- Sensitivity this rotary switch controls the detector sensitivity. During normal operation the sensitivity level is set to 3 or 4.

DIP Switch Functions

DIP	OFF	ON
1	Pulse on Relay II	Presence on Relay II
2	Pulse on detect	Pulse on Un-detect
3	Constant presence	4 minute limited presence time
4	"Fail Secure"	"Fail Safe"
5	Filter Off	Filter On
6	ASB Off	Automatic Sensitivity Boost On
7	Extend detect	6 seconds
8	Extend detect	3 seconds

When Dip 7 and 8 are in ON position the extend time is 9 seconds.

Warning: Do not use limited presence setting and / or "Fail Secure" setting for reversing gates, doors or barriers.

DIP - Detector Functions

1. Presence function is provided always by the presence relay output on pins 5, 6, and 10. These outputs are active when the detector detects a car. If there is a need for an additional presence output the Relay 2 can be configured as a second presence output by setting DIP 1 to ON position.
2. Pulse function is provided by the Relay 2 output on pins 3, 9, and 11. To obtain pulse on Relay 2 set DIP 1 to OFF position. The pulse of about 0.5 second can be generated when the car enters the loop or when it exits. To generate pulse on vehicle entry to the loop set DIP 2 to OFF position. To generate pulse on vehicle exit from the loop set DIP 2 to ON position.
3. The presence relay provides constant output as long as the car is detected on the loop. To obtain constant presence time set DIP 3 to OFF position. In some applications limited presence time is required. To obtain limited presence time of approximately 4 minutes set DIP 3 to ON position. Be aware that the detector relay will be released after 4 minutes even if the vehicle is still detected by the detector. This may be a serious hazard in applications where gates, doors or barriers are reversed, therefore never use this option in these applications.
4. When DIP 4 is set to ON position the detector works in "Fail Safe" mode of operation the detector will issue a detect signal when a car is detected, loop is disconnected or shorted, or when the power to the detector is interrupted. It is strongly recommended to use the detector in this mode.

In some application there is a need to ignore the loop or power failures and only to provide the detect signal when a car is detected on the loop. To ignore loop or power failures set the detector to "Fail Secure" by setting DIP 4 to OFF position. Do not use this setting for application where gates, doors or barriers have to be reversed.

Note: Functions on pins 6 and 10 are reversed if DIP 4 is set to OFF

5. In some applications it is necessary to filter out short detections such as cross traffic or short burst of radio frequency such as keying of a CB transmitter. To ignore these short detections set DIP 5 to ON position. This will cause any detection that is shorter than 2 seconds to be ignored.
6. To increase detection height when detecting high bed vehicles set DIP 6 to ON position. This setting will cause the sensitivity to automatically increase once the front axle of the truck is detected. The sensitivity will go back to the normal level once the truck left the loop.

NOTES

7. To extend the presence output for 6 seconds after the vehicle left the loop set DIP 7 to ON position.
8. To extend the presence output for 3 seconds after the vehicle left the loop set DIP 8 to ON position.

Note: If DIP 7 and DIP 8 are set to ON position the presence output will be extended 9 seconds after the vehicle left the loop.

Troubleshooting

Symptom	Possible Cause	Correction
Green indicator is not ON	No input voltage	1. Check voltage on pins 1 and 2. 2. Replace internal fuse 3. Check wiring to detector
Green indicator flashes	Loop wire shorted or disconnected	1. Check loop resistance on pins 7 and 8 it should be less than 5 ohms and more than 0.5 ohms.
Green indicator flashes with two consecutive fast blinks	Loop wire was temporarily shorted or disconnected	1. Check loop resistance on pins 7 and 8 while driving over the loop it should be less than 5 ohms and more than 0.5 ohms. The reading should be steady.
Detector stays in detect mode after the car left the loop and fails to undetect.	1. Faulty loop 2. Poorly crimped terminals 3. Loose connections	1. Perform megger test between loop lead and ground the reading should be larger than 100 megaohms. 2. Check that loop is tightly connected to proper terminals 3. Check that splices are tightly soldered and sealed against moisture.
Detector detects intermittently even when there is no car on the loop.	1. Faulty loop 2. Poorly crimped terminals 3. Loose connections 4. - Cross-talk between adjacent loop detectors	1. Perform megger test between loop lead and ground the reading should be larger than 100 megaohms. 2. Check that loop is tightly connected to proper terminals 3. Check that splices are tightly soldered and sealed against moisture. 4. Set adjacent loops on different frequencies.

TILT-A-WAY MODEL PSB M30B

Parts List	
PART NUMBER	DESCRIPTION
1	8 1/4-20 X 3/4 HEX BOLT
2	8 1/4 LOCK WASHER
3	8 1/4-20 HEX NUT
N/A	2 CONDUIT
N/A	1 BOLLARD RIGHT
N/A	1 BOLLARD LEFT
PEO404	2 PHOTO EYE

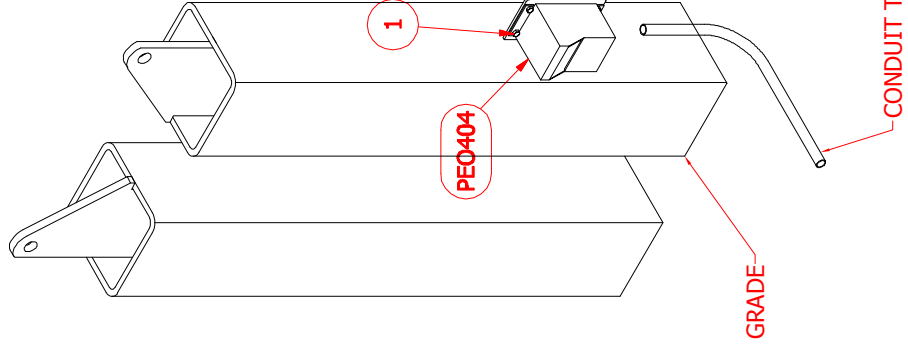
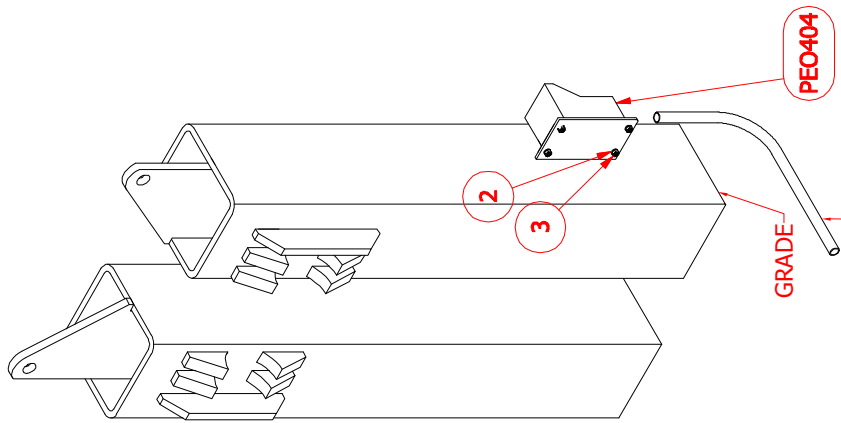
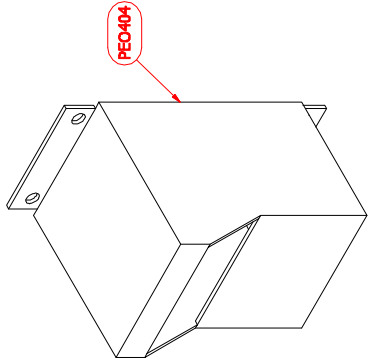

DRAWN T Henry	11/28/2011	IDEAL MFG., INC.
CHECKED	1/13/2016	TITLE
QA		PSB M30B PHOTO EYE BRACKET
MFG		SIZE
APPROVED		C
		DWG NO
		PSB M30B 125
		REV
		SCALE
		1
		SHEET 1 OF 1

RED ()
 TERMINAL 3 SAFETY (SET TIMER)
 T5 OPEN/ SAFETY (FREE EXIT)
 (SET TIMER)
 T12 CLOSE
 T13 OPEN

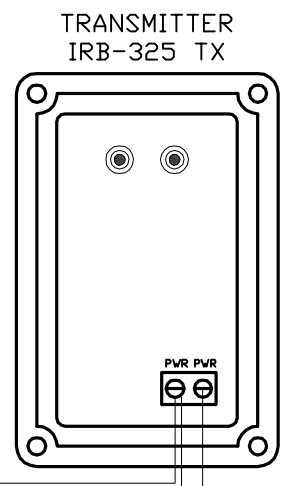
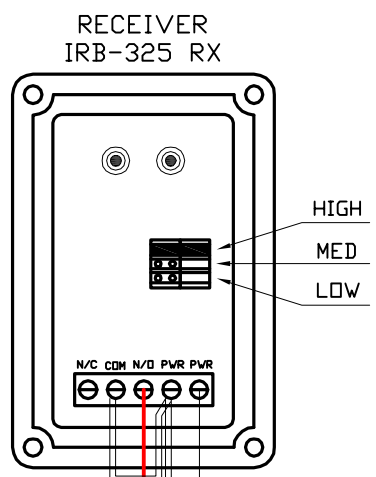
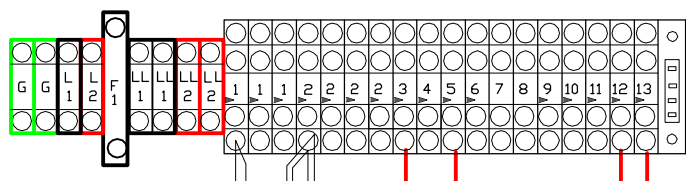

WHITE

TILT-A-WAY PATRIOT SECURITY BARRIER
 MODEL PSB M30B
 REFLECTIVE TYPE PHOTO EYE

REF NO.	PART NO.	DESCRIPTION	REQ NO
1	PEO404 (set)	Photo Eye 24VAC	1
2	PEO405	Hood (not shown)	2

WHITE

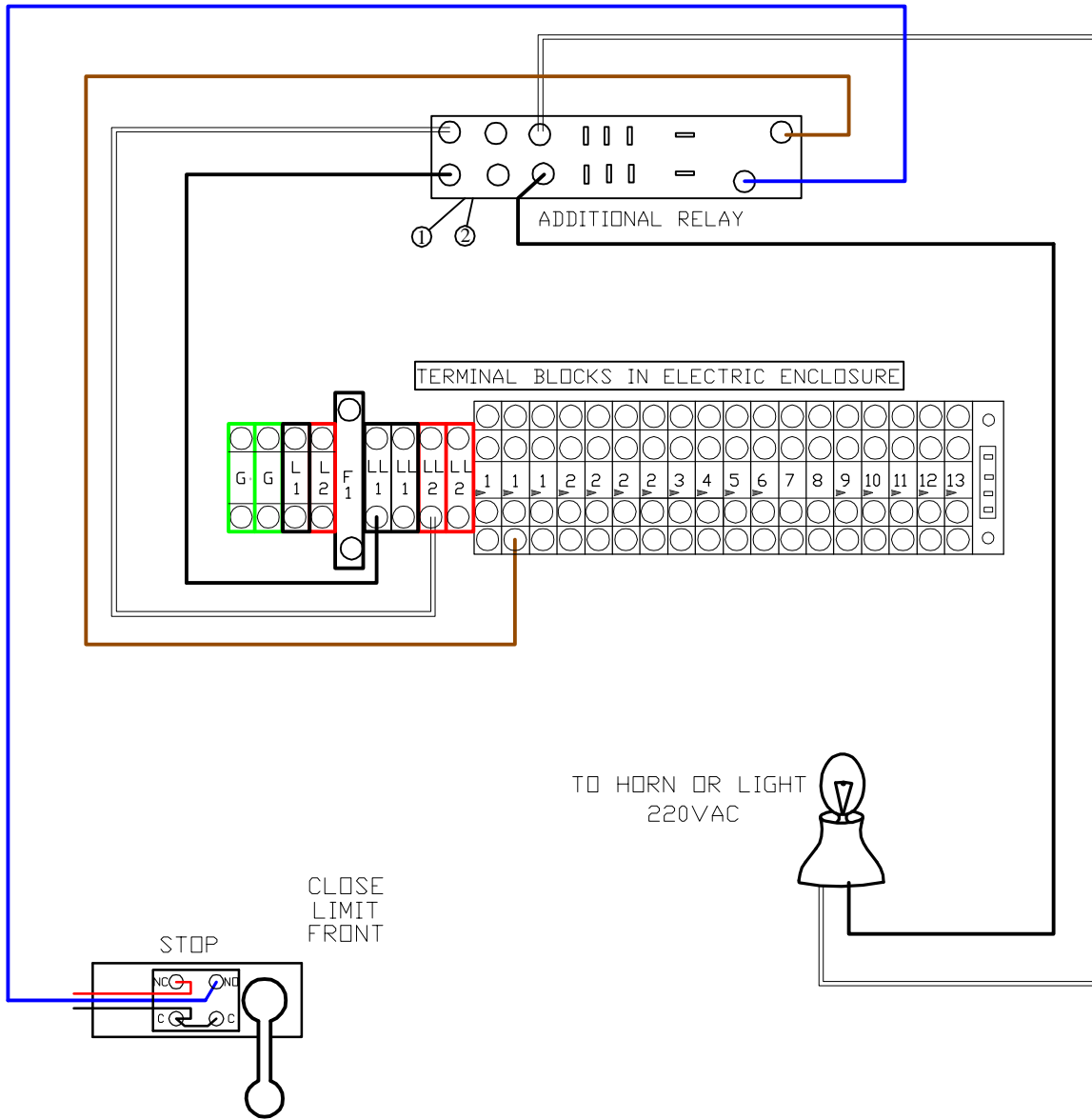

TILT-A-WAY PATRIOT SECURITY BARRIER
 PSB M30B
 208 /240 VAC SINGLE PHASE
 GATE OPEN INDICATOR

REF NO.	PART NO.	DESCRIPTION	REQ NO
1	PEO606A	Socket, Relay	1
2	PEO606	Relay	1
3		Vehicle Indicator Light (supplied by customer)	

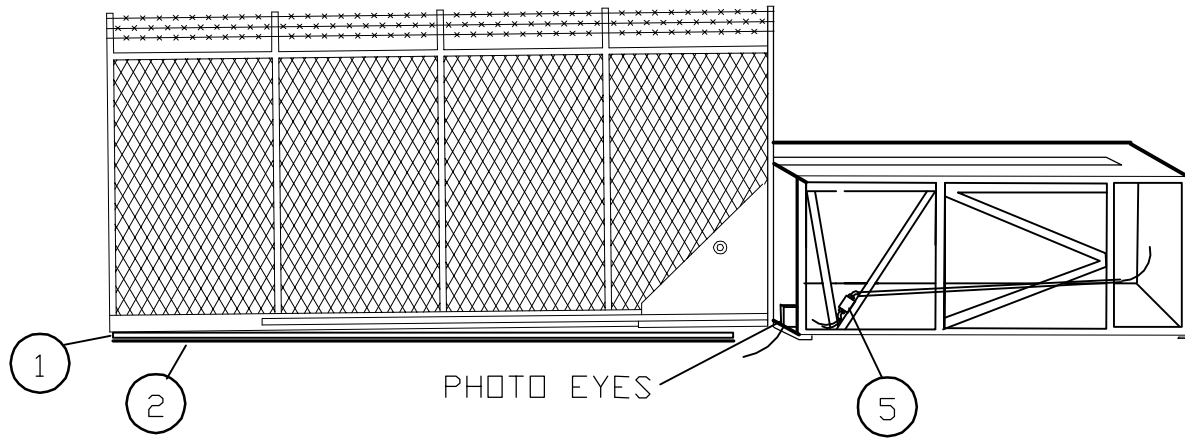

TERMINAL BLOCKS IN ELECTRICAL ENCLOSURE

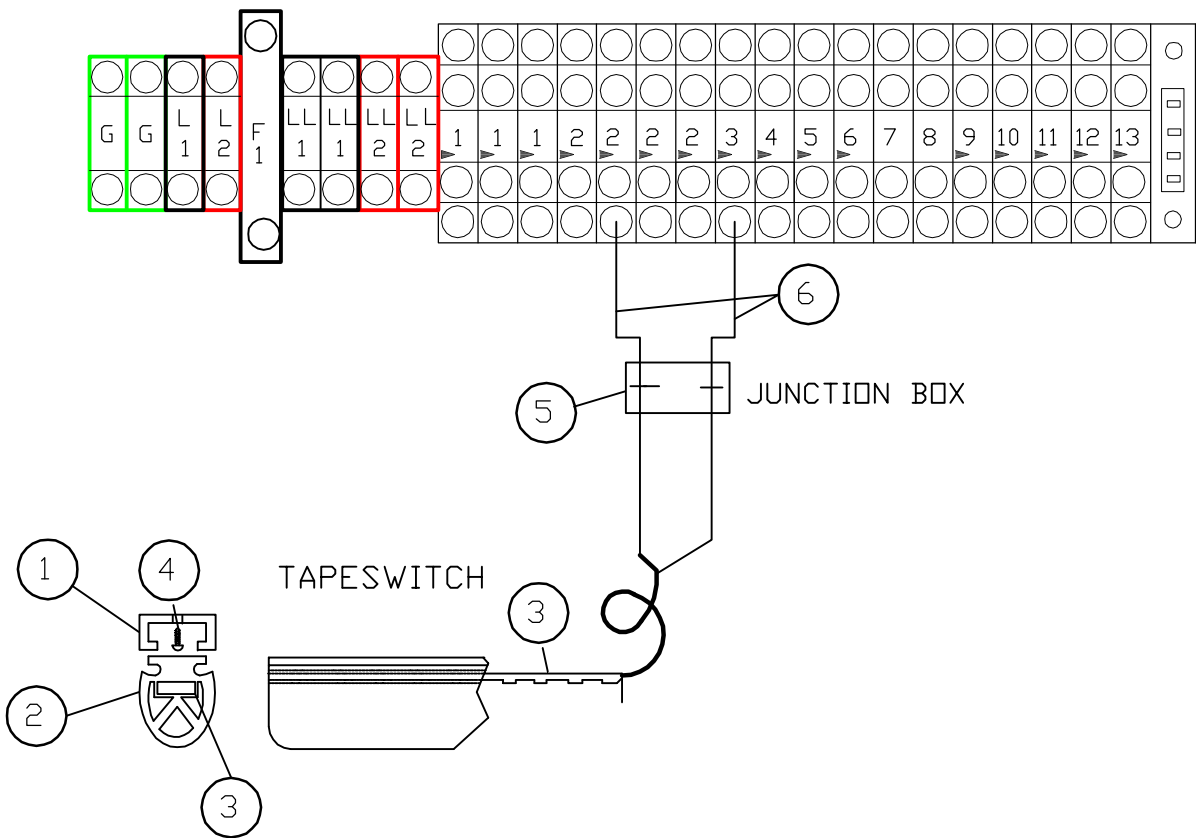

TILT-A-WAY PATRIOT SECURITY BARRIER
REVERSING EDGE INSTALLATION

REF NO.	PART NO.	DESCRIPTION	REQ NO
1	PEO243	Reversing Edge Holding Track (Length is required)	1
2	PEO243A	Reversing Edge Rubber Strip (Length is Required) (Insert in Track from front)	1
3	PEO244-Length	C Switch (Order Length as Required) (Insert in Tract from front)	1
4	N/A	8 x 3/4" Tapping Phillips Pan Head Screw	as req.
5	PEO410	Junction Box	1
6	N/A	16/2 S O Cord	9'
	PEO246	1/2" Strain Relief Fitting (not shown)	4
	PEO237	Junction Box Cover (not shown)	1

APPLICATION

The receiver can be used as a single or three channel receiver to control up to 3 gates or commercial door operators. The receiver can also be used with a 3-button remote control to operate the OPEN, CLOSE, and STOP feature on a commercial door operator. The receiver is not for use with MyQ™ enabled garage door openers or devices.

Each channel is compatible with a certain number of remote controls and keypads. Refer to the list below:

- CH1: 50 remote controls and 2 keypads
- CH2: 20 remote controls and 2 keypads
- CH3: 20 remote controls and 2 keypads

When the channel has reached full capacity for remote controls, all LEDs will blink 3 times. When the channel has reached full capacity for keypads, all LEDs will blink 4 times. Additional accessories can be programmed, however, the newly programmed accessory will replace the first programmed accessory.

NOTE: The receiver will only allow you to program a button on the remote control to one channel at a time. For example, if the button on the remote control is already programmed to channel 1 and then is programmed to channel 3, the button will be erased from channel 1 and will only work on channel 3.

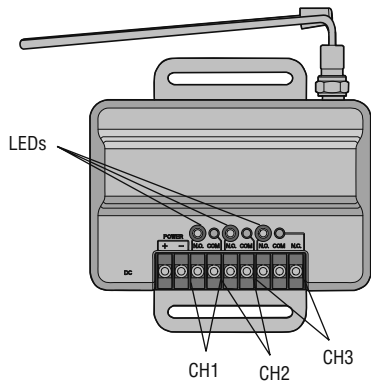

INSTALLATION

The receiver and antenna use TV Type F coaxial connectors. The antenna can be connected directly to the receiver or it can be installed remotely using a coaxial cable extension kit (Model 86LM, 15 ft. or 86LMT, 25 ft.).

- 1 Select a location for the receiver which allows access to the terminals and space for the antenna. Ensure antenna does not touch metal surfaces. DO NOT bend or fold the antenna.
- 2 Fasten the receiver securely with the hook and loop fasteners (provided) or screws (not provided).
- 3 After installation is complete, connect power. You may use 85LM plug-in or 95LM wired-in transformer, or power provided from your operator (9-30 V AC, 9-34 Vdc or see power ratings on next page).
NOTE: The receiver can command the operator to close the door or gate by constant pressure. This feature is only available with a wireless control panel (Model 885LM). To enable this feature, press and hold the push bar until the gate or garage door moves to the closed position.

⚡ ⚠ WARNING

- To prevent possible SERIOUS INJURY or DEATH from electrocution:
- Be sure power is NOT connected BEFORE installing the receiver.
- To prevent possible SERIOUS INJURY or DEATH from a moving gate or garage door:
- ALWAYS keep remote controls out of reach of children. NEVER permit children to operate, or play with remote control transmitters.
 - Activate gate or door ONLY when it can be seen clearly, is properly adjusted, and there are no obstructions to door travel.
 - ALWAYS keep gate or garage door in sight until completely closed. NEVER permit anyone to cross path of moving gate or door.

⚠ WARNING

To prevent possible SERIOUS INJURY or DEATH, the use of CONSTANT OPERATION on residential openers is PROHIBITED. When a receiver is used to activate a commercial door opener, a reversing edge MUST be installed on the bottom of the door. Failure to install a reversing edge under these circumstances may result in SERIOUS INJURY or DEATH to persons trapped beneath the door.

WIRING

Refer to your commercial door operator or gate operator owner manual or wiring diagrams for specific wiring information.

SINGLE CHANNEL

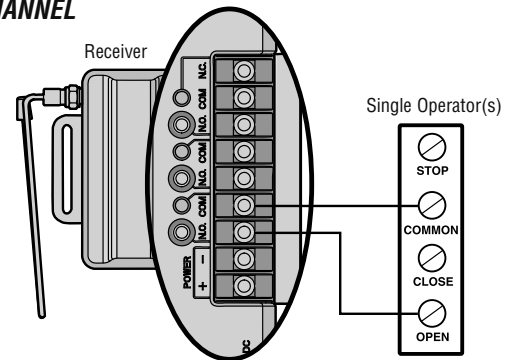

THREE CHANNEL

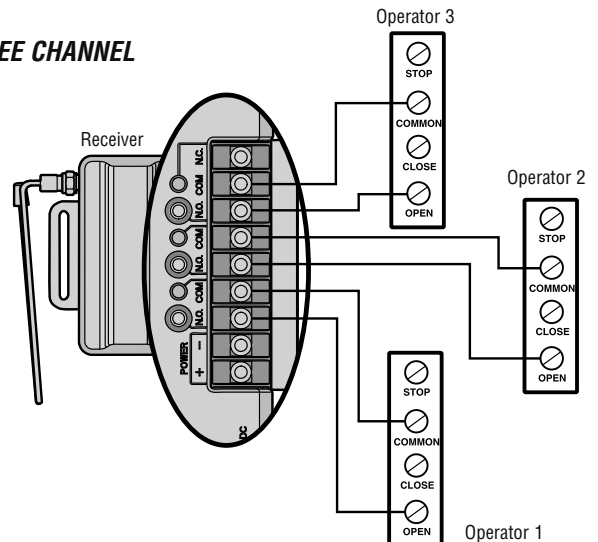

WIRING CONTINUED

OPEN, CLOSE, STOP

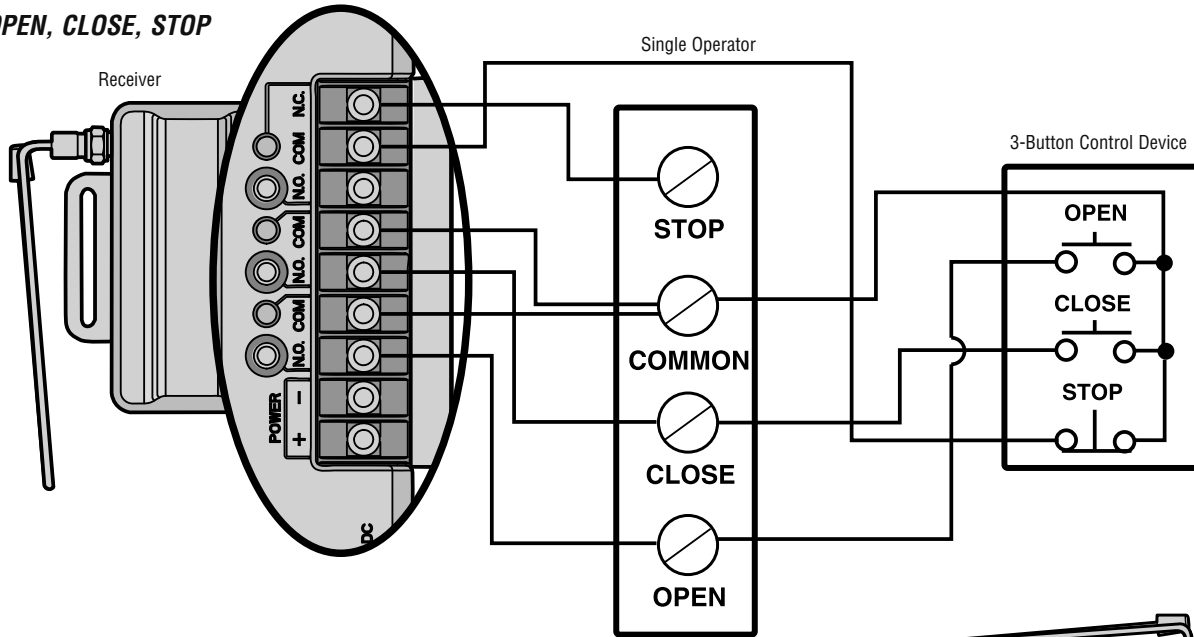

Refer to your commercial door operator or gate operator wiring diagrams for instructions on connecting two or more 3-Button control devices.

PROGRAMMING

PROGRAM A SINGLE BUTTON REMOTE CONTROL

- 1 Press and release the Learn button for the selected channel on the receiver. The corresponding LED will glow steadily for 30 seconds.
- 2 Within 30 seconds press and hold the button on the remote control that you wish to program to the receiver.
- 3 Release the remote control button when the LED on the receiver blinks, then turns off. Programming is complete.

Repeat the steps above for each remote control you would like to program.

PROGRAM A 3-BUTTON REMOTE CONTROL AS OPEN, CLOSE, AND STOP

- 1 Press and release the CH1 Learn button on the receiver.
- 2 Within 30 seconds press the desired OPEN button on the remote control.
- 3 Press and release the CH2 Learn button on the receiver.
- 4 Within 30 seconds press the desired CLOSE button on the remote control.
- 5 Press and release the CH3 Learn button on the receiver.
- 6 Within 30 seconds press the desired STOP button on the remote control.

NOTE: If a remote control button is not pressed within 30 seconds, the LED next to the selected Learn button will turn OFF. In that case, repeat the programming.

TO ERASE THE MEMORY

- 1 Press and hold the Learn button for the channel you want to erase. Release the button when the corresponding LED turns off; the memory has been erased.

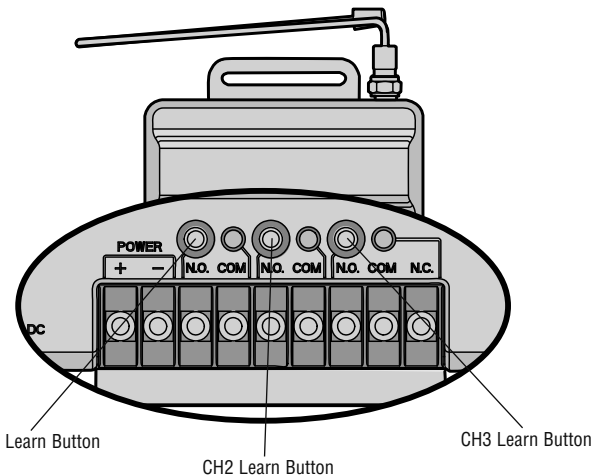

SPECIFICATIONS

Contact Rating 5 Amps 28 Vac or dc Max.
 Power. 9-30V AC or 9-34V DC, 50mA, 60Hz
 RF Frequency: 310, 315, and 390 MHz

NOTE: If your operator does not meet the power specifications you will need a transformer (Model 85LM plug-in or 95LM wired-in).

COMPATIBLE ACCESSORIES

Remote Controls Models 811LM, 813LM, 891LM, 893LM, 890MAX, 893MAX, 895MAX, 892LT, 894LT
 Keypads Models 877LM, 877MAX
 Antenna Extension Kits Models 86LM, 86LMT
 Antenna Only K77-36541

NOTICE: To comply with FCC and/or Industry Canada (IC) rules, adjustment or modifications of this receiver are prohibited. THERE ARE NO USER SERVICEABLE PARTS.
 This device complies with Part 15 of the FCC rules and IC RSS-210. Operation is subject to the following two conditions: (1) this device may not cause harmful interference, and (2) this device must accept any interference received, including interference that may cause undesired operation.

FOR TECHNICAL SUPPORT DIAL OUR TOLL FREE NUMBER:

1-800-528-2806

UTILISATION

Cet appareil peut s'utiliser comme récepteur à un ou trois canaux de manière à commander jusqu'à trois ouvre-porte ou ouvre-portail commerciaux. Il peut aussi s'utiliser avec une télécommande à 3 boutons pour actionner les fonctions **OUVERTURE**, **FERMETURE** et **ARRÊT** d'un ouvre-porte commercial. Il n'est pas conçu pour fonctionner avec les ouvre-porte et autres appareils compatibles MyQ™.

Chaque canal est compatible avec un certain nombre de télécommandes et de claviers comme indiqué ci-dessous :

- Canal 1 : 50 télécommandes et 2 claviers
- Canal 2 : 20 télécommandes et 2 claviers
- Canal 3 : 20 télécommandes et 2 claviers

Lorsque le canal a atteint la pleine capacité des télécommandes, tous les témoins DEL clignotent trois fois. Lorsque le canal a atteint la pleine capacité des claviers, tous les témoins DEL clignotent quatre fois. On peut programmer des accessoires supplémentaires; toutefois, l'accessoire nouvellement programmé remplacera celui qui a été programmé en premier.

REMARQUE : Le récepteur ne vous permet de programmer un bouton de télécommande que pour un seul canal à la fois. Par exemple, si le bouton de la télécommande est déjà programmé pour le canal 1, puis pour le canal 3, il sera effacé du canal 1 et ne fonctionnera que sur le canal 3.

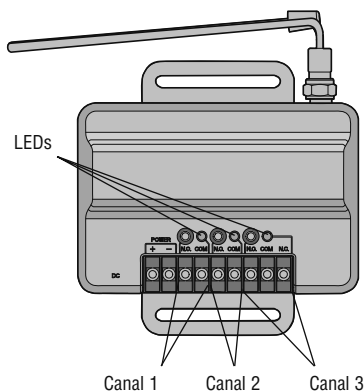

INSTALLATION

Le récepteur et l'antenne utilisent des connecteurs coaxiaux de type F. L'antenne peut être connectée directement au récepteur ou installée à distance avec une rallonge coaxiale modèle 86LM (4,57 m) ou 86LMT (7,62 m).

- 1 Choisir pour installer le récepteur un emplacement permettant d'accéder aux bornes et laissant assez d'espace pour l'antenne. S'assurer que l'antenne ne touche pas de surfaces métalliques. NE PAS plier ou courber l'antenne.
- 2 Fixer solidement le récepteur avec les bandes auto-agrippantes (fournies) ou avec des vis (non fournies).
- 3 Une fois l'installation terminée, branchez le cordon d'alimentation. Vous pouvez utiliser un transformateur 85LM à prise ou 95LM à câble, ou alimenté par votre opérateur (9-30 V c.a., 9-34 V c.c. ou consultez les régimes d'alimentation à la page suivante).

REMARQUE : Le récepteur peut commander à l'opérateur de fermer la porte ou le portail par une pression constante. Cette fonction est uniquement disponible avec un panneau de commande sans fil (modèle 885LM). Pour activer cette fonction, appuyez sur la barre de poussée et gardez-la enfoncée jusqu'à ce que le portail ou la porte de garage se déplace vers la position fermée.



AVERTISSEMENT

Pour prévenir le risque de BLESSURES GRAVES ou de DÉCÈS par électrocution :

- S'assurer que l'alimentation n'est PAS branchée AVANT d'installer le récepteur.

Pour prévenir le risque de BLESSURES GRAVES ou de DÉCÈS causés par un portail ou une porte de garage en mouvement :

- TOUJOURS tenir les télécommandes hors de portée des enfants. Ne JAMAIS laisser un enfant utiliser une télécommande ou jouer avec.
- Actionner la porte ou le portail UNIQUEMENT lorsqu'ils sont bien visibles et bien ajustés et que rien ne fait obstacle à leur mouvement.
- TOUJOURS surveiller du regard le portail ou la porte de garage jusqu'à sa fermeture complète. Ne JAMAIS laisser personne franchir une porte ou un portail en mouvement.



AVERTISSEMENT

Pour prévenir le risque de BLESSURES GRAVES ou de DÉCÈS, il est INTERDIT d'utiliser les ouvre-porte résidentiels EN FONCTIONNEMENT CONTINUËL.

Avant d'utiliser un récepteur pour actionner un ouvre-porte commercial, il est IMPÉRATIF d'installer une tranche de sécurité (barre palpeuse) au bas de la porte. L'absence de tranche de sécurité convenablement installée peut entraîner des BLESSURES GRAVES ou un DÉCÈS si quelqu'un se retrouve coincé sous la porte.

CÂBLAGE

Pour obtenir des informations précises sur le câblage, consulter la notice ou les schémas de câblage de l'ouvre-porte ou ouvre-portail.

UN CANAL

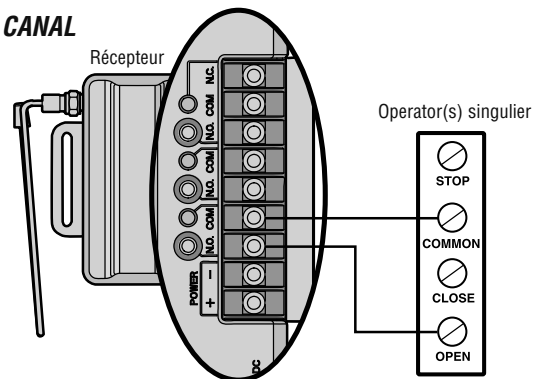

TROIS CANAL

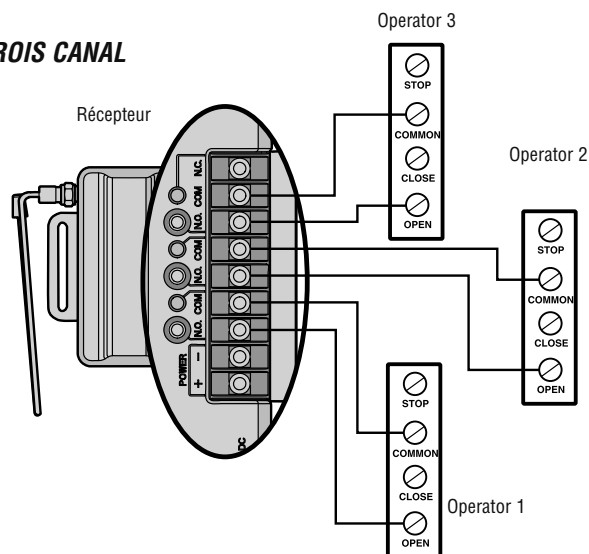

CÂBLAGE (SUITE)

OUVERTURE, FERMETURE,
ARRÊT

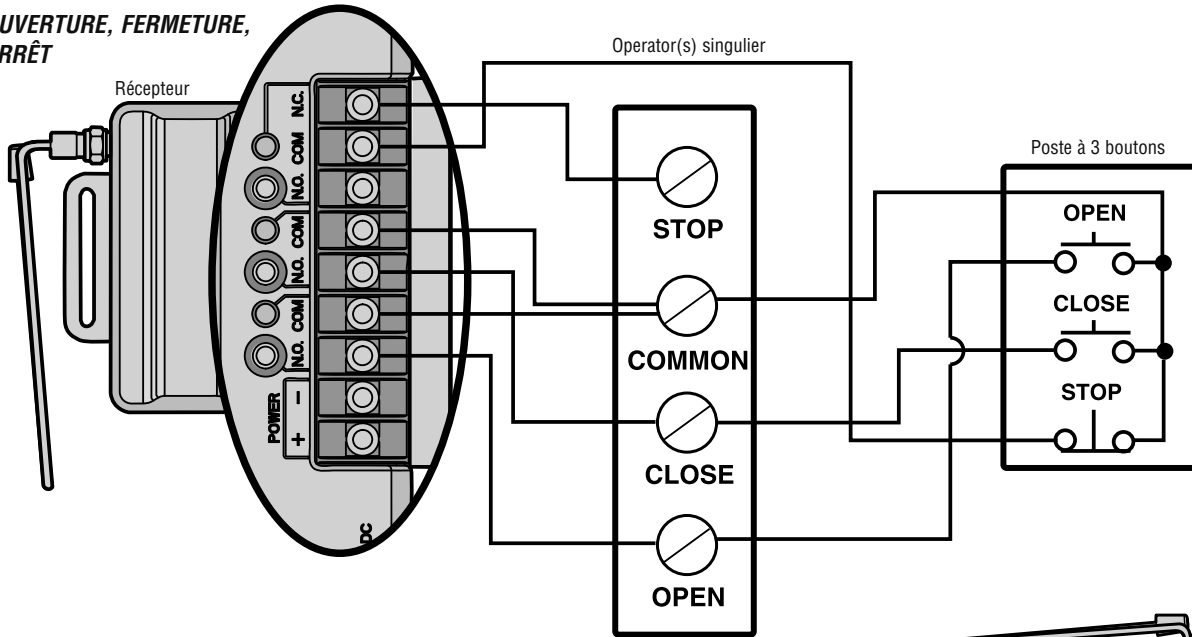

Consulter les schémas de câblage de l'ouvre-porte ou de l'ouvre-portail pour obtenir des instructions sur la connexion de deux ou plusieurs télécommandes à 3 boutons.

PROGRAMMATION

PROGRAMACIÓN DE UN CONTROL REMOTO DE 1 BOTÓN

- 1 Presser et relâcher le bouton de programmation du canal sélectionné sur le récepteur. Le témoin correspondant s'allume et reste allumé pendant 30 secondes.
- 2 Dans les 30 secondes, presser et maintenir enfoncé le bouton de la télécommande à programmer pour ce récepteur.
- 3 Le témoin du récepteur se met à clignoter, puis s'éteint. Relâcher alors le bouton de la télécommande. La programmation est terminée.

Répéter les étapes ci-dessus pour chaque télécommande à programmer.

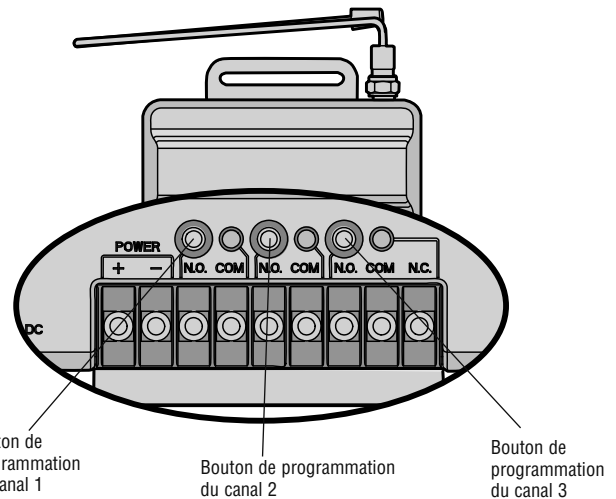

PROGRAMMATION DES FONCTIONS OUVERTURE, FERMETURE ET ARRÊT D'UNE TÉLÉCOMMANDE À 3 BOUTONS

- 1 Presser et relâcher le bouton de programmation du canal 1 sur le récepteur.
- 2 Dans les 30 secondes, appuyer sur le bouton d'ouverture souhaité sur la télécommande.
- 3 Presser et relâcher le bouton de programmation du canal 2 sur le récepteur.
- 4 Dans les 30 secondes, appuyer sur le bouton de fermeture souhaité sur la télécommande.
- 5 Presser et relâcher le bouton de programmation du canal 3 du récepteur.
- 6 Dans les 30 secondes, appuyer sur le bouton d'arrêt souhaité sur la télécommande.

REMARQUE : Si aucun bouton de la télécommande n'est enfoncé dans les 30 secondes, le témoin du bouton de programmation sélectionné s'éteint. Dans ce cas, recommencer la programmation.

POUR EFFACER LA MÉMOIRE

- 1 Presser et maintenir enfoncé le bouton de programmation du canal à effacer. Relâcher le bouton lorsque le témoin correspondant s'éteint. La mémoire est alors effacée.

CARACTÉRISTIQUES TECHNIQUES

Régime de contact 5 A, 28 V (c.a. ou c.c.) max.
Alimentation 9 à 30 V c.a. ou 9 à 34 V c.c., 50 mA, 60 Hz
Fréquences radio 310, 315 et 390 MHz

REMARQUE : Si l'ouvre-porte ou l'ouvre-portail ne répond pas à ces spécifications électriques, il est nécessaire d'utiliser un transformateur modèle 85LM (à fiche de branchement) ou 95LM (à câblage direct).

ACCESSOIRES COMPATIBLES

Télécommandes . . Modèles 811LM, 813LM, 891LM, 893LM, 890MAX, 893MAX, 895MAX, 892LT, 894LT
Claviers Modèles 877LM, 877MAX
Rallonges d'antenne Modèles 86LM, 86LMT
Antenne seule K77-36541

AVIS : Conformément aux règlements de la FCC et d'Industrie Canada, il est interdit de modifier ce récepteur ou ses réglages d'origine. CET APPAREIL NE COMPORTE AUCUNE PIÈCE POUVANT ÊTRE RÉPARÉE PAR L'UTILISATEUR.

Cet appareil est conforme à la partie 15 des règlements de la FCC et à la norme RSS-210 d'Industrie Canada. Son utilisation est subordonnée aux deux conditions suivantes : (1) l'appareil ne doit pas causer d'interférences nuisibles et (2) l'appareil doit accepter toute interférence reçue, y compris celles qui pourraient un fonctionnement indésirable.

POUR L'ASSISTANCE TECHNIQUE, APPELER LE NUMÉRO SANS FRAIS SUIVANT :

1-800-528-2806

© 2011, The Chamberlain Group, Inc.
All Rights Reserved
Tous droits réservés

Introduction

This product is for use with models 850LM and 860LM universal receivers as well as any Security+ 2.0™ compatible LiftMaster gate operators. Depending on the receiver channel, you may program up to 20 or 50 remote control dip switch configurations to your receiver. To exceed the 20/50 limit, match the dip switches in the new remote control to the dip switches in an existing remote control.



811LM



813LM

WARNING

To prevent possible **SERIOUS INJURY** or **DEATH** from a moving gate or garage door:

- ALWAYS keep remote controls out of reach of children. NEVER permit children to operate, or play with remote control transmitters.
- Activate gate or door ONLY when it can be seen clearly, is properly adjusted, and there are no obstructions to door travel.
- ALWAYS keep gate or garage door in sight until completely closed. NEVER permit anyone to cross path of moving gate or door.

Set the Dip Switches

- 1 Slide the cover open to access the dip switches in the remote control.
- 2 Use a pen or screwdriver to slide the dip switches to any position you want (ON or OFF).

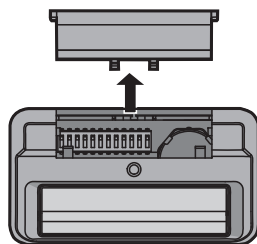

Programming

- 1 Press and release the Learn button for the selected channel on the receiver. The corresponding LED will glow steadily for 30 seconds.
- 2 Within 30 seconds press and hold the button on the remote control that you wish to program to the receiver.
- 3 Release the remote control button when the LED on the receiver blinks, then turns off. Programming is complete.

Repeat the steps above for each remote control you would like to program.

If you would like to program an 813LM as an OPEN, CLOSE, STOP, refer to the 850LM receiver manual.

For programming to the 860LM receiver or to a Security+ 2.0™ compatible gate operator, please refer to the receiver/operator instructions manual for location of the learn button(s).

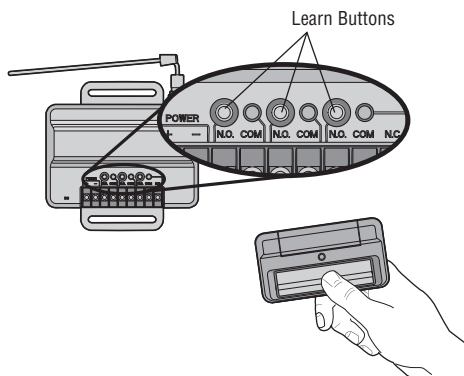

The Remote Control Battery

The 3 volt battery should produce power for 1 year. Dispose of old batteries properly.

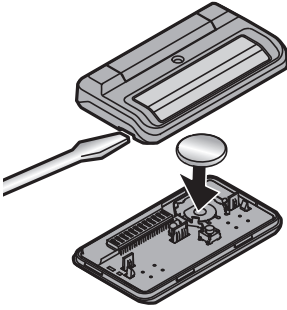

WARNING

To prevent possible **SERIOUS INJURY** or **DEATH**:

- NEVER allow small children near batteries.
- If battery is swallowed, immediately notify doctor.

NOTICE: To comply with FCC and/or Industry Canada (IC) rules, adjustment or modifications of this transceiver are prohibited. THERE ARE NO USER SERVICEABLE PARTS.

This device complies with Part 15 of the FCC rules and IC RSS-210. Operation is subject to the following two conditions: (1) this device may not cause harmful interference, and (2) this device must accept any interference received, including interference that may cause undesired operation.

Replacement Parts

Visor Clip	29C137
3V Battery	10A20

FOR TECHNICAL SUPPORT DIAL OUR TOLL FREE NUMBER:

1-800-528-9131

www.liftmaster.com

Introduction

Cet article est utilisé avec les récepteurs universels modèles 850LM et 860LM, ainsi qu'avec toute commande de barrière LiftMaster compatible au Security+ 2.0™. Selon le canal de réception, vous pouvez programmer de 20 à 50 configurations de commutateurs DIP de télécommande sur votre récepteur. Pour dépasser la limite 20/50, appariez les commutateurs DIP de la nouvelle télécommande aux commutateurs DIP de la télécommande existante.



811LM



813LM

! AVERTISSEMENT

Afin d'éliminer les risques de BLESSURES GRAVES ou de MORT découlant de l'actionnement d'une clôture ou d'une porte de garage :

- TOUJOURS garder les télécommandes hors de la portée des enfants. NE JAMAIS laisser un enfant manipuler une télécommande ni jouer avec elle.
- Actionner la clôture ou la porte UNIQUEMENT lorsqu'elle est clairement visible, correctement ajustée et que le mécanisme est libre de toute entrave.
- TOUJOURS garder la clôture ou la porte de garage en vue jusqu'à sa fermeture complète. NE permettez à quiconque de passer lorsqu'une clôture ou une porte est en mouvement.

Réglage des commutateurs DIP

- 1 Ouvrez le couvercle en le faisant glisser pour avoir accès aux commutateurs DIP de la télécommande.
- 2 À l'aide d'une plume ou d'un tournevis, glissez les commutateurs DIP à la position souhaitée (ON ou OFF).

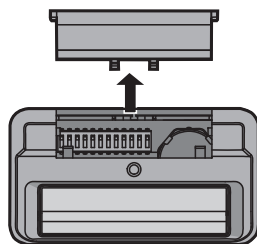

Programmation

- 1 Pressez puis relâchez le bouton Learn du canal sélectionné sur le récepteur. Le voyant DEL correspondant reste allumé pendant 30 secondes.
- 2 Dans les 30 secondes, pressez et maintenez le bouton de la télécommande que vous voulez programmer sur le récepteur.
- 3 Relâchez le bouton de la télécommande lorsque le voyant DEL du récepteur clignote, puis s'éteint. La programmation est terminée.

Reprenez les étapes précédentes avec chaque télécommande que vous souhaitez programmer.

Reportez-vous au manuel du récepteur 850LM si vous souhaitez programmer les fonctions OPEN, CLOSE, STOP (ouverture, fermeture, arrêt) sur un 813LM.

Pour programmer sur le récepteur 860LM ou un dispositif de commande compatible à un Security+ 2.0™, reportez-vous au manuel d'instructions récepteur/dispositif de commande pour l'emplacement du/des bouton(s) Learn.

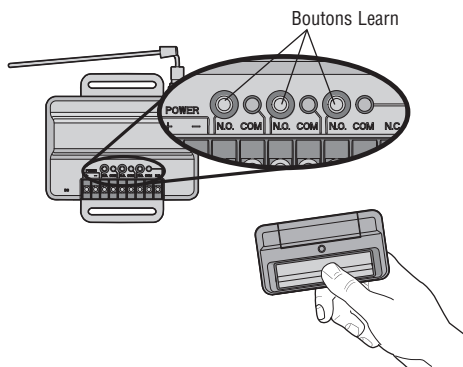

La pile de télécommande

La pile de 3 V devrait produire suffisamment de puissance pour au moins un an. Se débarrasser des vieilles piles convenablement.

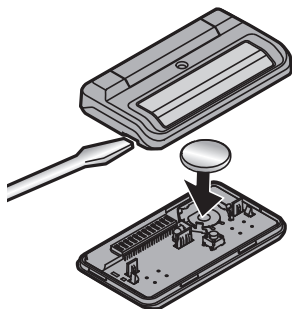

! AVERTISSEMENT

Pour prévenir d'éventuelles BLESSURES GRAVES ou la MORT :

- Ne JAMAIS laisser de petits enfants à proximité des piles.
- Aviser immédiatement un médecin en cas d'ingestion de la pile.

AVIS : Les règles de la FCC et/ou d'Industrie Canada (IC) interdisent tout ajustement ou toute modification de ce récepteur. IL N'EXISTE AUCUNE PIÈCE SUSCEPTIBLE D'ÊTRE ENTRETENUE PAR L'UTILISATEUR.

Cet appareil est conforme aux dispositions de la partie 15 du règlement de la FCC et de la norme IC RSS-210. Son utilisation est assujettie aux deux conditions suivantes : (1) ce dispositif ne peut causer des interférences nuisibles, et (2) ce dispositif doit accepter toute interférence reçue, y compris une interférence pouvant causer un fonctionnement non souhaité.

Pièces de rechange

Pince du pare-soleil29C137
Pile de 3V10A20

POUR OBTENIR DE L'ASSISTANCE TECHNIQUE, COMPOSER NOTRE NUMÉRO GRATUIT :

1-800-528-9131

www.liftmaster.com

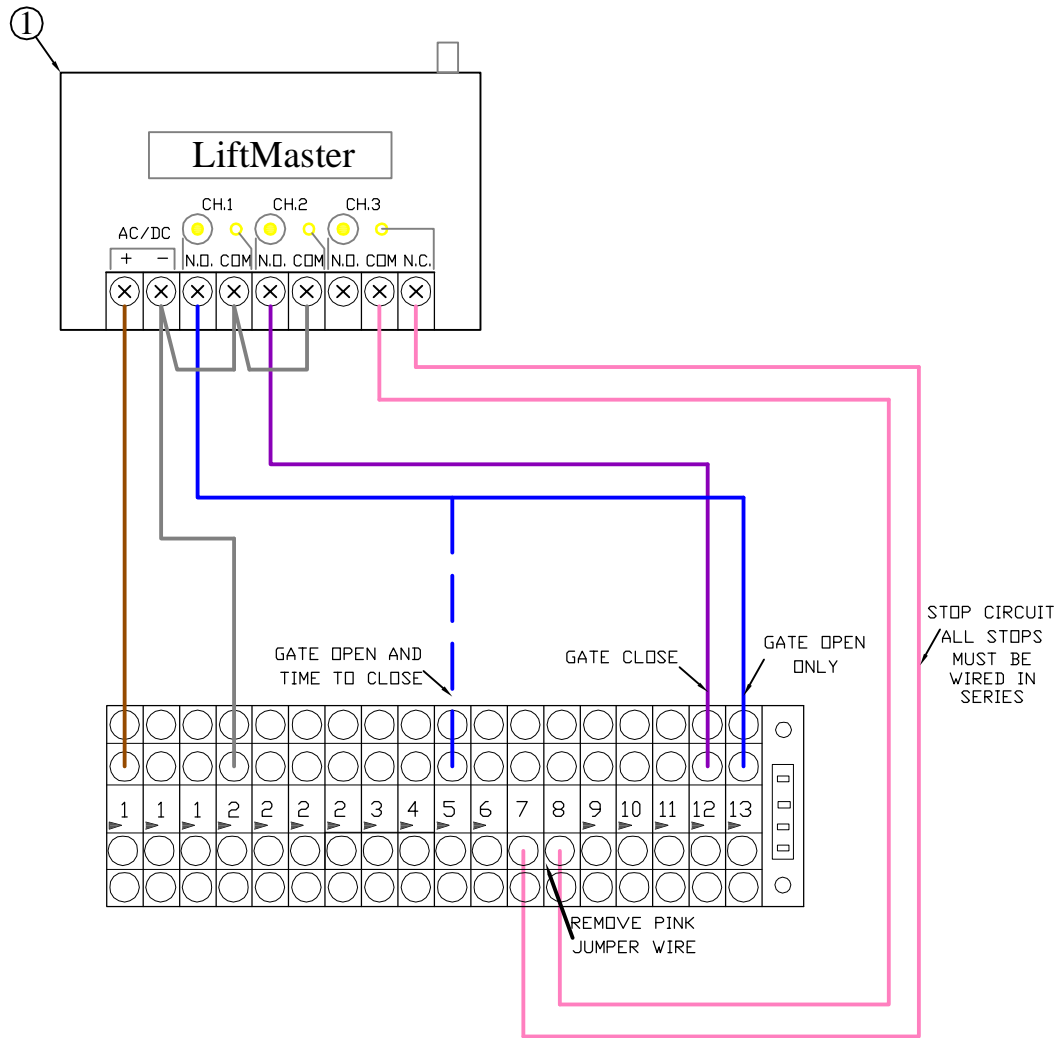

NOTE:
ALL STOP CONNECTIONS IN SERIES

**TILT-A-WAY
PATRIOT SECURITY BARRIER
PSB M30B
RADIO RECEIVER - THREE BUTTON**

REF. NO.	PART NO.	DESCRIPTION	REQ. NO.
1	PEO272	Radio Receiver Model 850LM	1
2	PEO273A	Radio Transmitter 1-Button Model 811LM	as req
3	PEO273B	Radio Transmitter 3-Button Model 813LM	as req

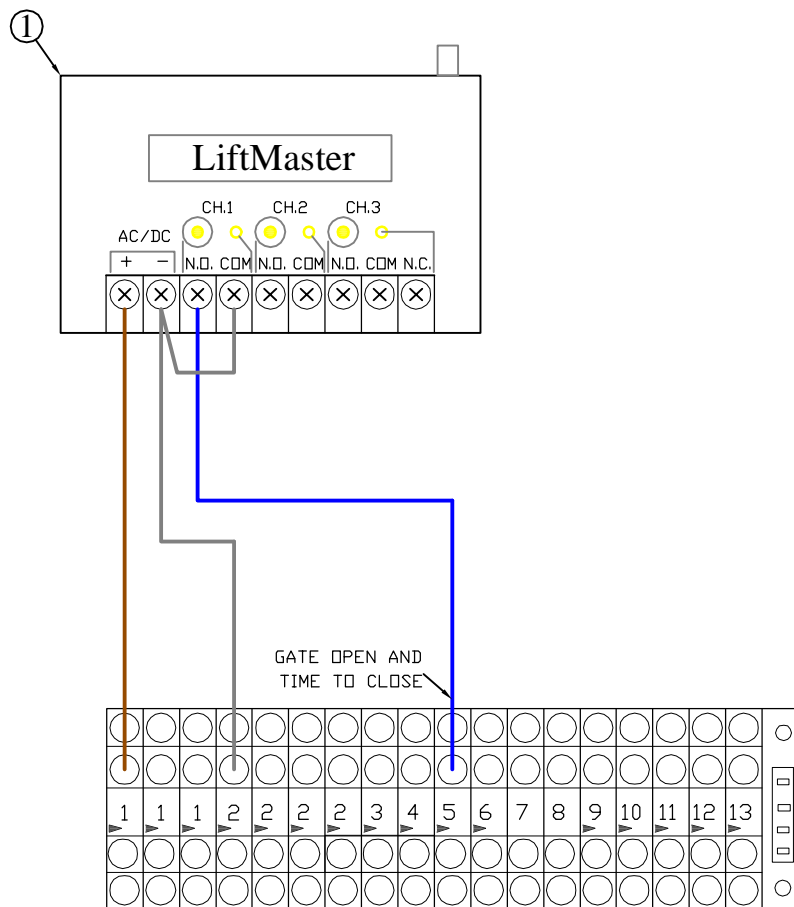

NOTE:

ALL STOP CONNECTIONS IN SERIES

**TILT-A-WAY
PATRIOT SECURITY BARRIER
PSB M30B
RADIO RECEIVER - SINGLE BUTTON**

REF. NO.	PART NO.	DESCRIPTION	REQ. NO.
1	PEO272	Radio Receiver Model 850LM	1
2	PEO273A	Radio Transmitter 1-Button Model 811LM	as req
3	PEO273B	Radio Transmitter 3-Button Model 813LM	as req

PSB M30B TROUBLE SHOOTING GUIDE

PROBLEM

CIRCUIT BOARD LIGHTS (ON)

SOLUTIONS

	P O W E R	S A F E T Y	A U X	T I M E R	T I M E R H O L D	S T O P L I M I T	O P E N L I M I T	C L O S E L I M I T	S I N G L E	C L O S E	O P E N	G A T E O P E N	G A T E C L O S E	T I M E R A C T I V E		
Gate stopped in any position	X X X					X X X	X X X						X			1 Check for power 2 Check for broken spring or cable 3 Overload relay tripped ? 4 Stop circuit broken (terminals 7 & 8) 5 Over run timer reached, manual valves open or low oil pressure, out of oil. 6 Over run timer reached same as #5
Gate stopped in open position	X X X X	X				X X X X	X X X							X		1 Safety circuit activated (remove wires from terminal 3 until light goes out, trace wire to trouble) 2 Timer circuit activated (remove wire from terminal 5 until light goes out, trace wire to trouble) 3 gate timing, safety and timer must be deactivated to resume operation. 4 Close limit failure
Gate stopped in close position	X X X				X	X X X	X X						X			1 Open limit failure 2 Timer item failure (keypad, card reader, open and set timer button, etc. replace board) 3 Open button failure (replace board)
Motor runs but gate does not operate (shown in closed position)	X X X					X X X	X X X					X X X	X X X			1 Check manual valves (close if needed) 2 Check for valve operation (240 VAC at coils)
Gate opens but motor does not stop running	X					X X X	X X X									1 Open limit failure
Gate closes but motor does not stop running	X X					X X X	X X X									1 Close limit failure 2 Close limit needs to be adjusted
Contactors pull in but motor does not run	X X X					X X X	X X X									1 Check wiring at contactor 2 Check wiring in motor junction box 3 Check for motor failure (local motor shop)
Gate runs considerably slower in one direction	X X					X X	X X X									1 Check to see that both manual valves are closed 2 Check balance of barrier (open manual valves and raise barrier by hand checking to see if gate will stay put in any position-adjust springs accordingly)
Gate operates in jerky inconsistent manner	X					X X X	X X X									1 Check oil level (use Citgo-CP hydraulic fluid)
Motor runs in jerky inconsistent manner	X X					X X	X X X									1 Check voltage while running (over 3% drop unacceptable) (compare to cover voltage) 2 Oil pressure too high (consult mfg.)
Plastic covering coming off of cable (shut off power when inspecting balance system)																1 Normal wear cable can be lubed (replace cable if 5 broken strands per lay or 10 broken strands over all)
Gate squeaking while operating (shut off power)																1 Cable connections dry lube with cable lube 2 Check cable sheave bearings (replace as needed)
Barrier no longer slows down before reaching limit	X					X X	X									1 Check operation of slow down valves (240 VAC)

*The stop and both limit circuits are NC therefore the light goes out when that circuit is activated.

*When calling Ideal Mfg. for technical help, please note the lights during the problem occurring for easier trouble shooting.