

8X6 BRE EXTERIOR ISO VIEW

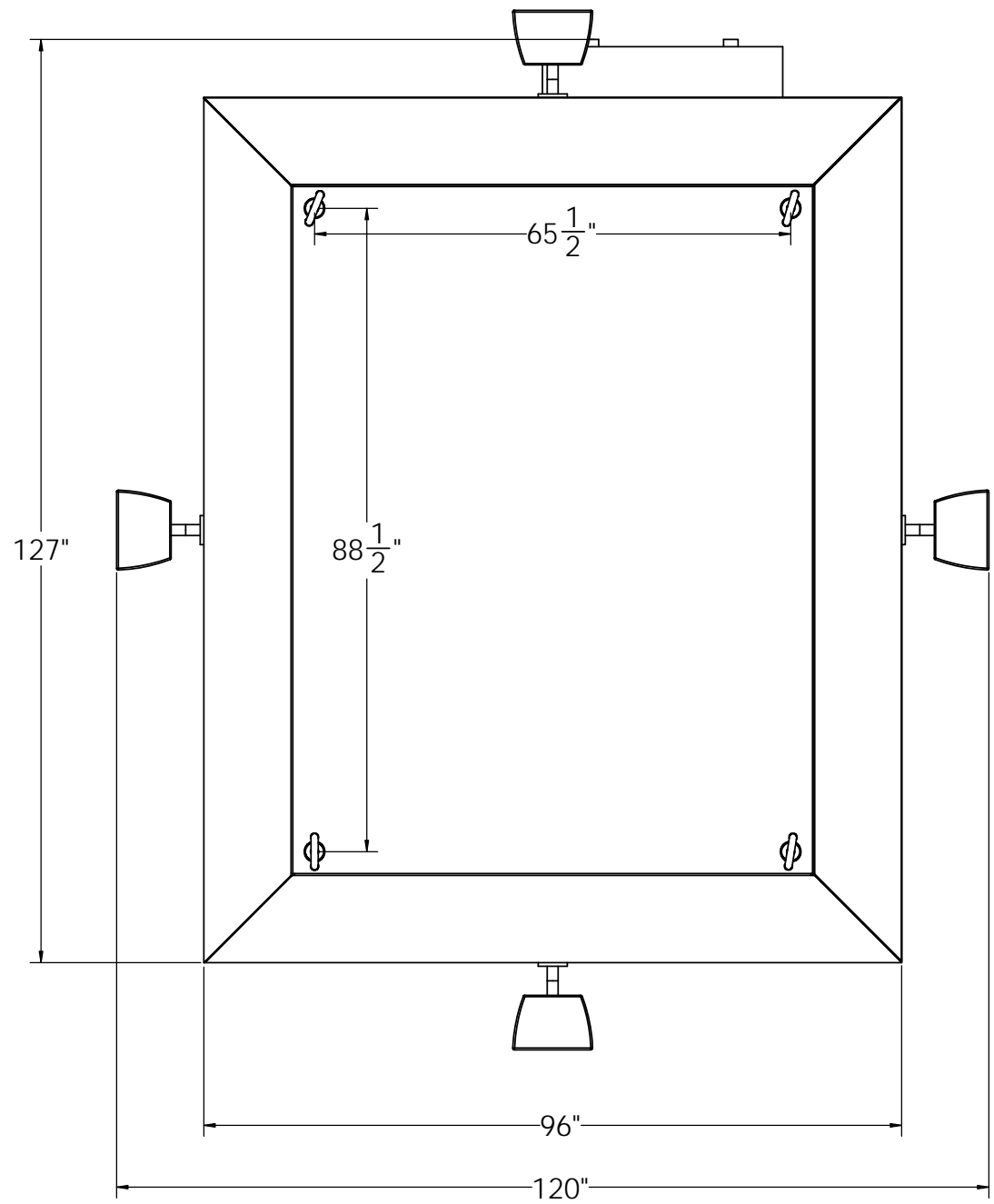

8X6 BRE TOP VIEW AND LIFTER LAYOUT

WILL BE SHIPPED WITHOUT
GLARE LIGHTS ATTACHED, BUT THEY WILL
BE WIRED.

PROPRIETARY AND CONFIDENTIAL
THE INFORMATION
CONTAINED IN THIS
DRAWING IS THE SOLE
PROPERTY OF KONTEK.
ANY PRODUCTION IN
PART OR AS A WHOLE
WITHOUT THE WRITTEN
PERMISSION OF KONTEK
IS PROHIBITED.

DRAWN	NAME	DATE
CHECKED	AJB	11/28/2017
APPROVED		
SHEET SIZE	SCALE	REV.
D	NIS	1 11/28/2017

	805 McCombs Avenue Kannapolis, NC 28083	
	DWG. NO. K17041	SHEET 1

8X6 MOBILE BRE
APPROVAL

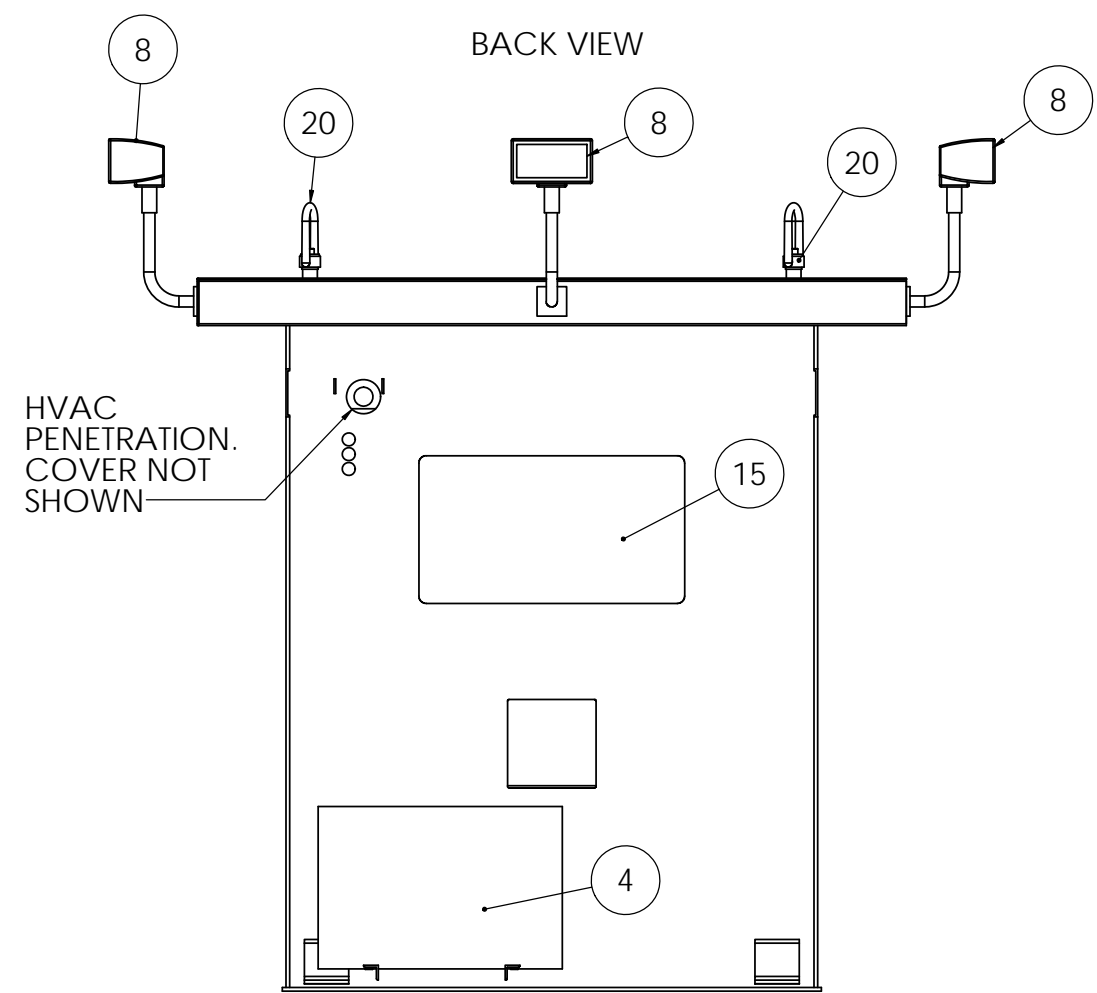
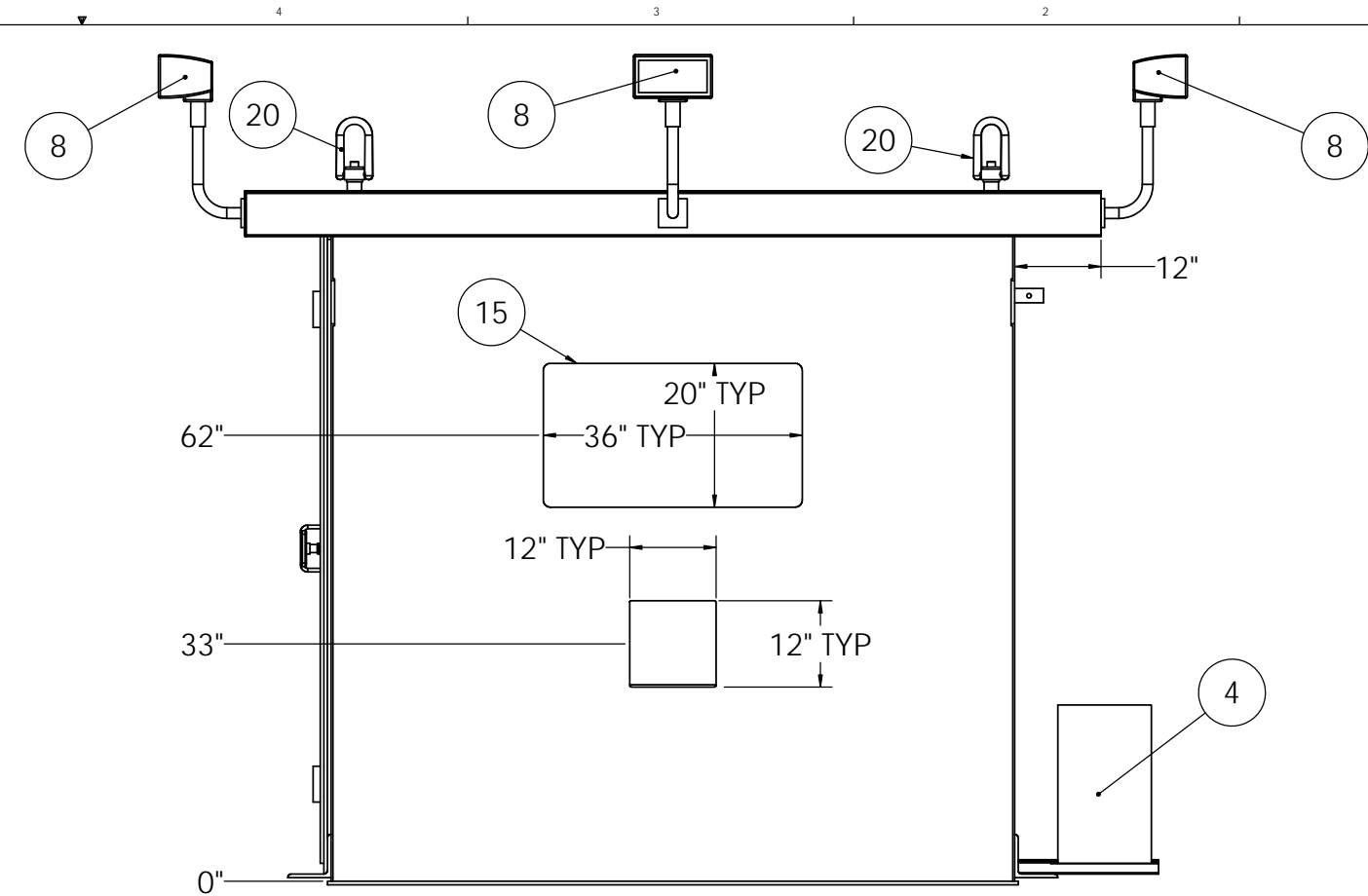
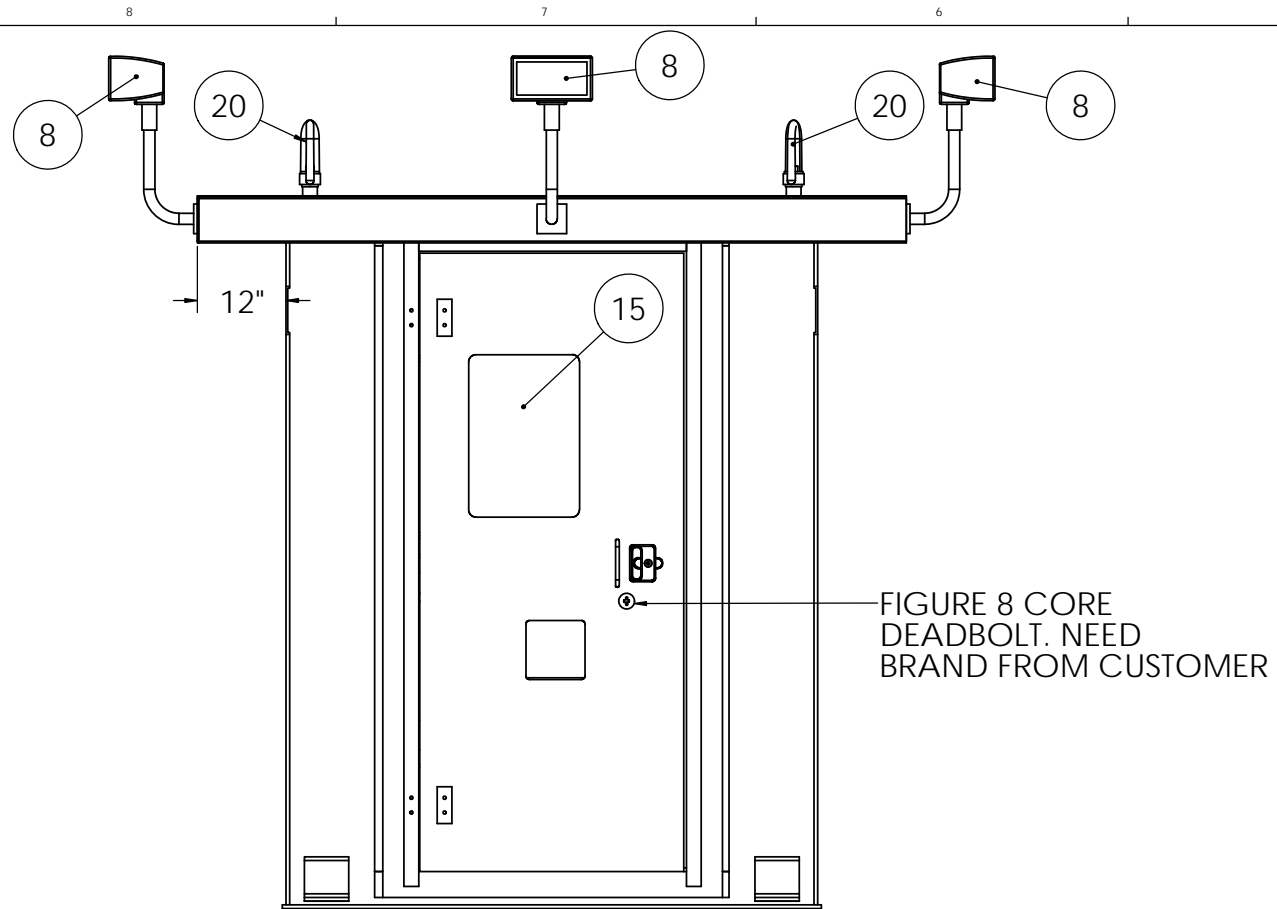

SIDE VIEW (LH AND RH)

ALL EXTERIOR PLATING FROM 1/2" AR500 - NIJ4 RATED

FRONT VIEW

<small>PROPRIETARY AND CONFIDENTIAL</small> <small>THE INFORMATION CONTAINED IN THIS DRAWING IS THE SOLE PROPERTY OF KONTEK. ANY PRODUCTION IN PART OR AS A WHOLE WITHOUT THE WRITTEN PERMISSION OF KONTEK IS PROHIBITED.</small>	<small>DRAWN</small> AJB	<small>NAME</small> 	<small>DATE</small> 11/28/2017
	<small>CHECKED</small> 		
	<small>APPROVED</small> 		
<small>SHEET SIZE</small> D	<small>SCALE</small> N1S	<small>REV.</small> 1 11/28/2017	 <small>805 McCombs Avenue Kannapolis, NC 28083</small>
<small>EXTERIOR ELEVATIONS</small>			<small>DWG. NO.</small> K17041 <small>SHEET 2</small>

5 - FOR FFLED WIRING PENETRATION

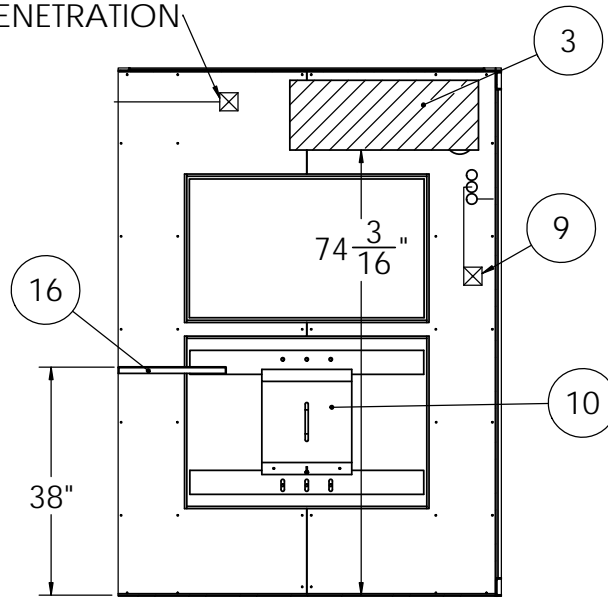

FRONT WALL INTERIOR VIEW

5 - FOR FFLED WIRING PENETRATION

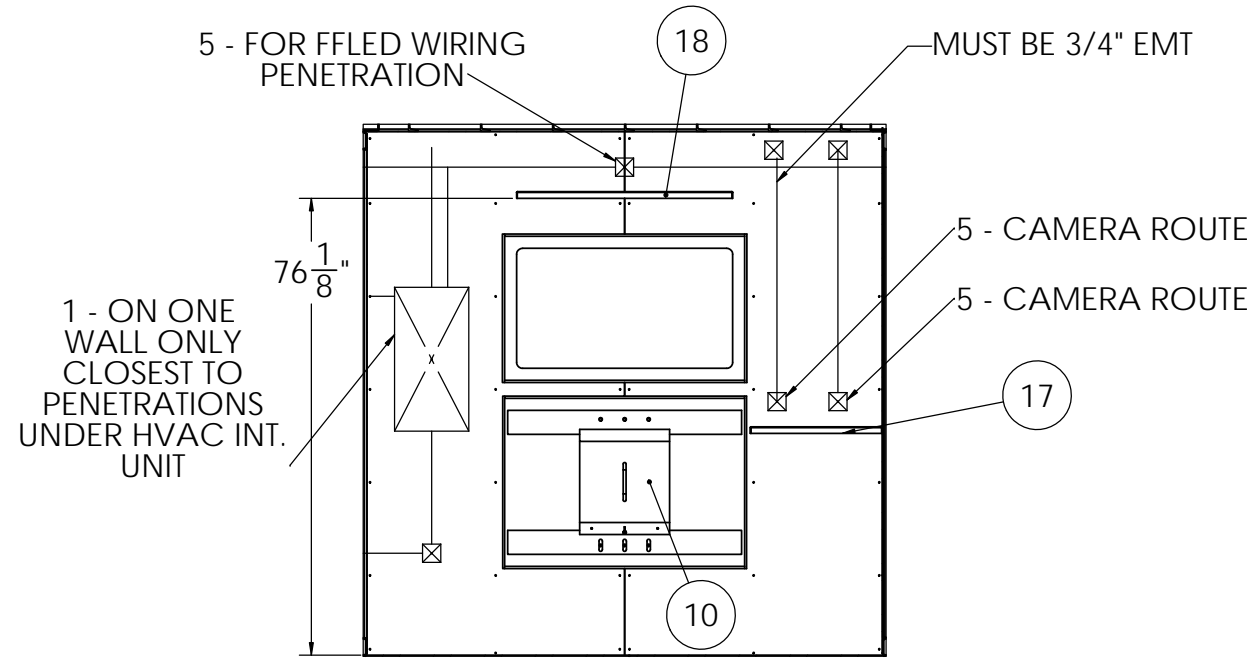

SIDE WALL INTERIOR VIEW

DOOR

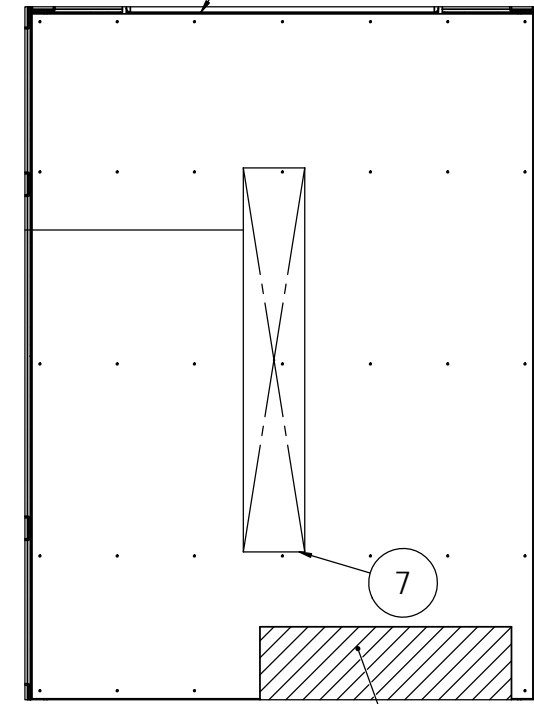

CEILING VIEW

5 - FOR FFLED WIRING PENETRATION

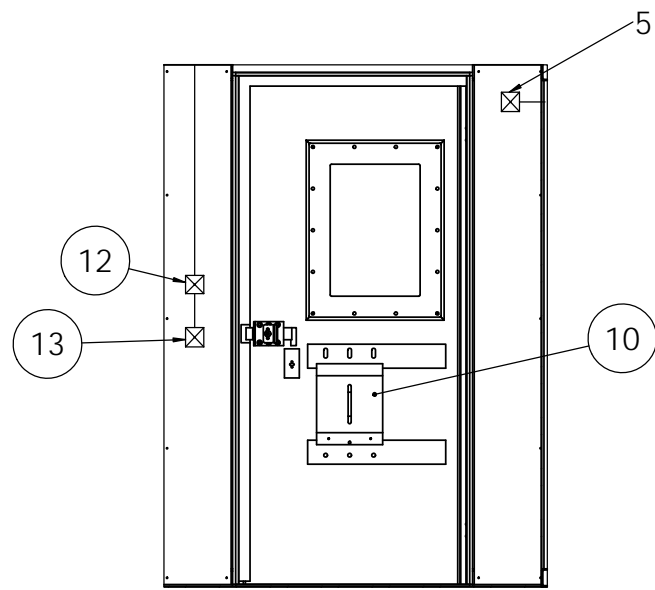

BACK WALL INTERIOR VIEW

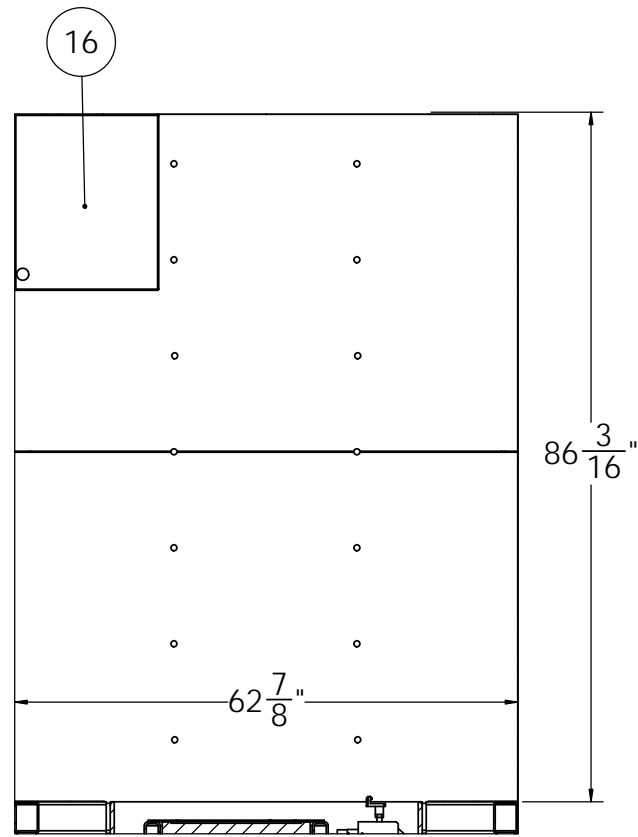

FLOOR PLAN

PROPRIETARY AND CONFIDENTIAL
 THE INFORMATION CONTAINED IN THIS DRAWING IS THE SOLE PROPERTY OF KONTEK. ANY PRODUCTION IN PART OR AS A WHOLE WITHOUT THE WRITTEN PERMISSION OF KONTEK IS PROHIBITED.

DRAWN	NAME	DATE
CHECKED	AJB	11/28/2017
APPROVED		
SHEET SIZE	SCALE	REV.
D	NIS	1
		11/28/2017

KONTEK 805 McCombs Avenue
Kannapolis, NC 28083

INTERIOR ELEVATIONS

DWG. NO. **K17041**
SHEET 3

RAILS BOLT TO TAP PADS WITH SIX 1/2-13 BOLTS.

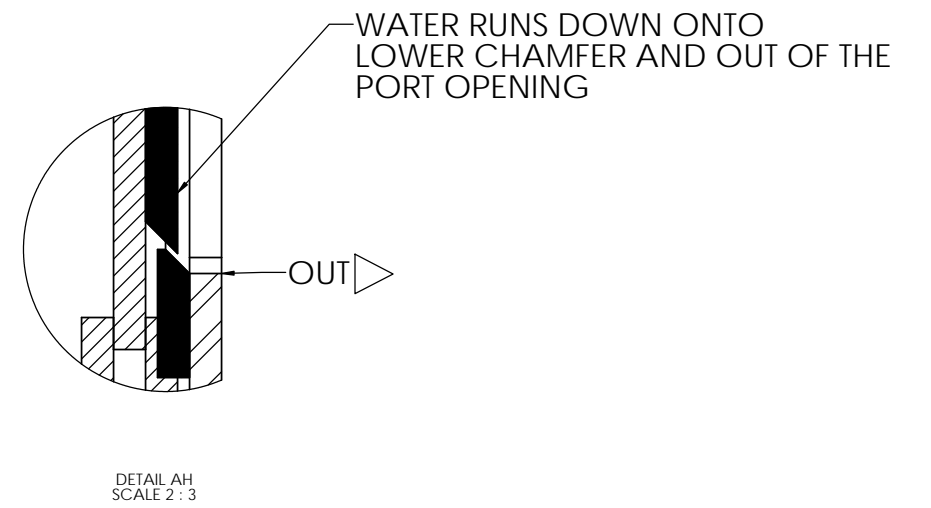
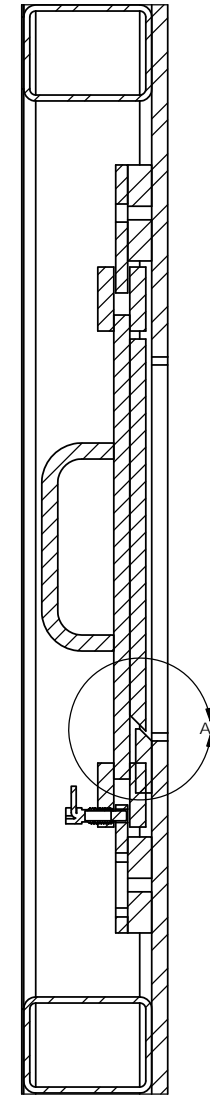
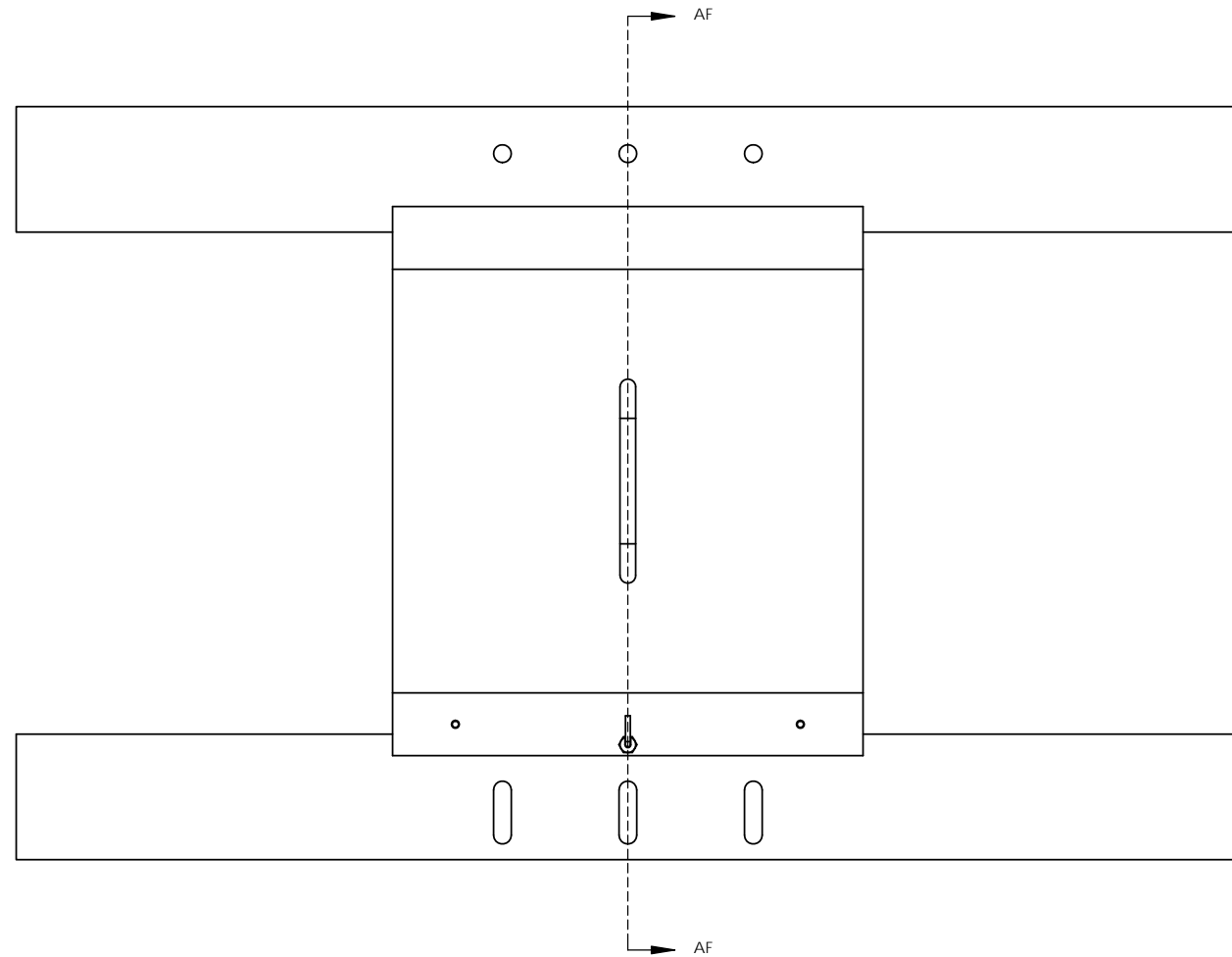

SECTION AF

GUN PORT SEALS BY USING TWO 45 DEG CHAMFERED SECTIONS (IN BLACK DETAIL AH) TO ALLOW WATER TO RUN OUT OF PORT OPENING

<small>PROPRIETARY AND CONFIDENTIAL</small> <small>THE INFORMATION CONTAINED IN THIS DRAWING IS THE SOLE PROPERTY OF KONTEK. ANY PRODUCTION IN PART OR AS A WHOLE WITHOUT THE WRITTEN PERMISSION OF KONTEK IS PROHIBITED.</small>	<small>DRAWN</small> AJB	<small>NAME</small> AJB	<small>DATE</small> 11/28/2017
	<small>CHECKED</small> 		
	<small>APPROVED</small> 		
<small>SHEET SIZE</small> D	<small>SCALE</small> NIS	<small>REV.</small> 1 11/28/2017	 <small>805 McCombs Avenue Kannapolis, NC 28083</small>
GUN PORT OVERVIEW			<small>DWG. NO.</small> K17041 <small>SHEET 4</small>