

GROUND RETRACTABLE CRASH BEAM - MODEL HCB-EL-400 (ELECTRICALLY OPERATED, REDUCED RISK)

STOPS 15,000 LB. VEHICLE AT 30 MPH IMPACT (BARRIER CERTIFIED UP TO 48 FEET CLEAR SPAN LENGTHS)

ASTM F2656-07 M30(K4) CERTIFIED, APPROVED BY DoD AND ON ANTI-RAM LIST

TYPICAL LAYOUT - 1 INBOUND AND 1 OUTBOUND LANE (2 LANE ROAD)

NOTE:

BARRIER LAYOUT SHOWN BELOW TO BE MODIFIED BASED ON SITE SPECIFIC CONDITIONS.

PLAN VIEW

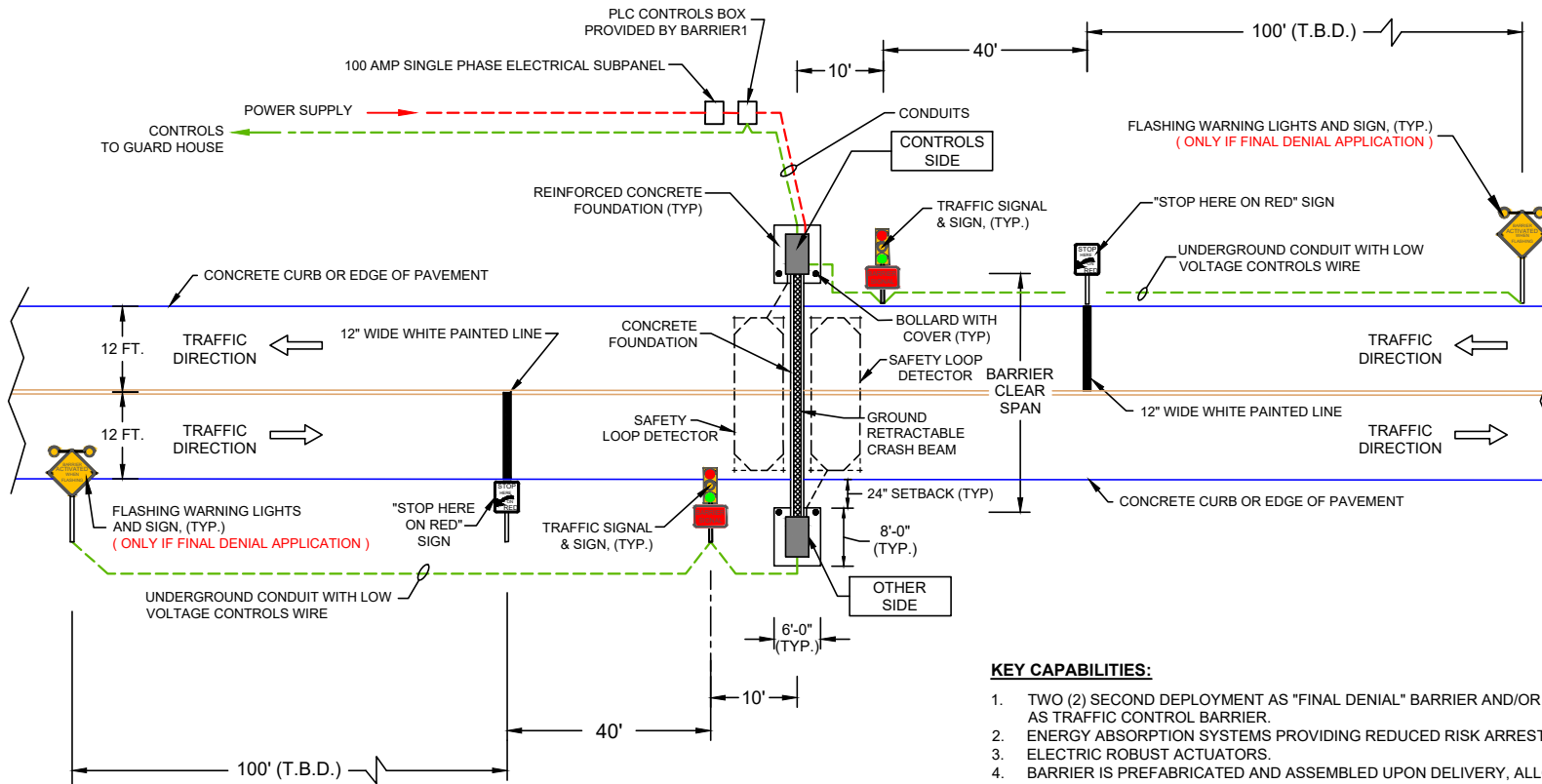

KEY CAPABILITIES:

1. TWO (2) SECOND DEPLOYMENT AS "FINAL DENIAL" BARRIER AND/OR "HIGH CYCLE" CAPABILITY AS TRAFFIC CONTROL BARRIER.
2. ENERGY ABSORPTION SYSTEMS PROVIDING REDUCED RISK ARRESTING.
3. ELECTRIC ROBUST ACTUATORS.
4. BARRIER IS PREFABRICATED AND ASSEMBLED UPON DELIVERY, ALLOWING FOR QUICK INSTALLATION.
5. BARRIER ARM PROVIDES A VISUAL DETERRENT. (SAFETY YELLOW WITH RETRO REFLECTIVE STRIPES)
6. BI-DIRECTIONAL STOPPING CAPABILITY. CERTIFIED TO STOP INBOUND AND OUTBOUND IMPACTS.
7. AUTOMATIC ELECTRIC LOCKING IN DOWN POSITION.
8. OPTIONAL UPS BACKUP POWER PROVIDES 10+ UP/DOWN CYCLES, OVER 2 HOURS.
9. AESTHETIC ENCLOSURES WITH LOCKING ACCESS DOORS. (NON-RUSTING)
10. ONLY 5 INCH WIDE OPENING ACROSS ROADWAY. A 4 INCH SPACE BELOW IS PROVIDED WHEN BEAM IS RETRACTED.
11. CUSTOM COLORS AVAILABLE.



BARRIER1 SYSTEMS, INC.

8015 THORNDIKE ROAD
GREENSBORO, NC 27409
(336) 617-8478 (336) 617-8471 FAX
miamore@barrier1.us www.barrier1.us

THE DRAWINGS AND INFORMATION CONTAINED HEREIN ARE PROPRIETARY AND CONFIDENTIAL, AND FOR USE BY ONLY PERSONS WORKING ON PROJECT WITH BARRIER1 SYSTEMS, INC. DO NOT COPY OR REPRODUCE. ALL RIGHTS RESERVED.

**GROUND RETRACTABLE
FINAL DENIAL CRASH BEAM
ELECTRICALLY OPERATED**

SAMPLE DRAWINGS

SHEET: 1 OF 10

06222017

SCALE: N.T.S.

GROUND RETRACTABLE CRASH BEAM - MODEL HCB-EL-400 (ELECTRICALLY OPERATED, REDUCED RISK)

STOPS 15,000 LB. VEHICLE AT 30 MPH IMPACT (BARRIER CERTIFIED UP TO 48 FEET CLEAR SPAN LENGTHS)

ASTM F2656-07 M30(K4) CERTIFIED, APPROVED BY DoD AND ON ANTI-RAM LIST

TYPICAL SECTIONS ACROSS ROADWAY

ELEVATION VIEW - RAISED POSITION

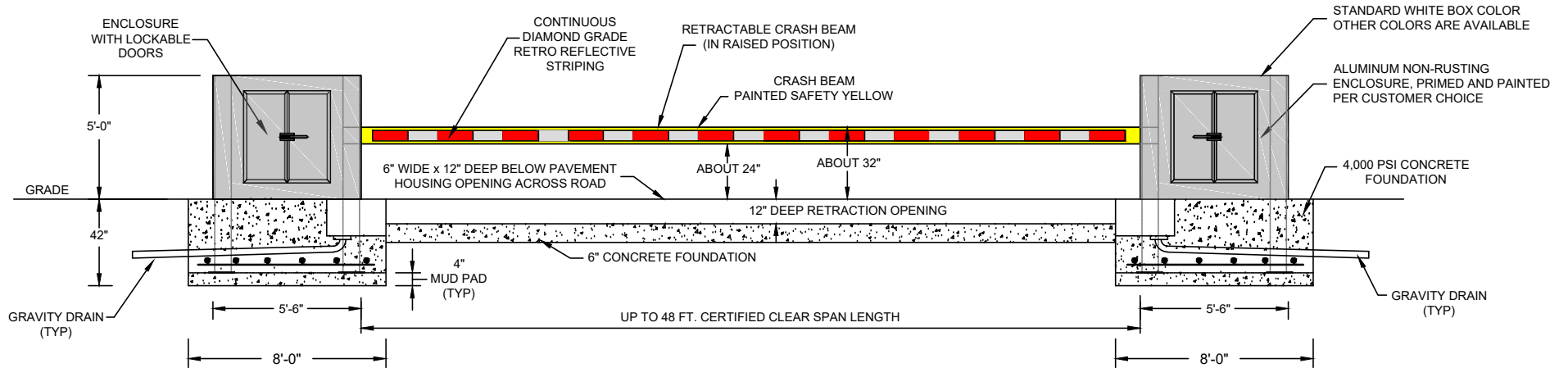

ELEVATION VIEW - LOWERED POSITION

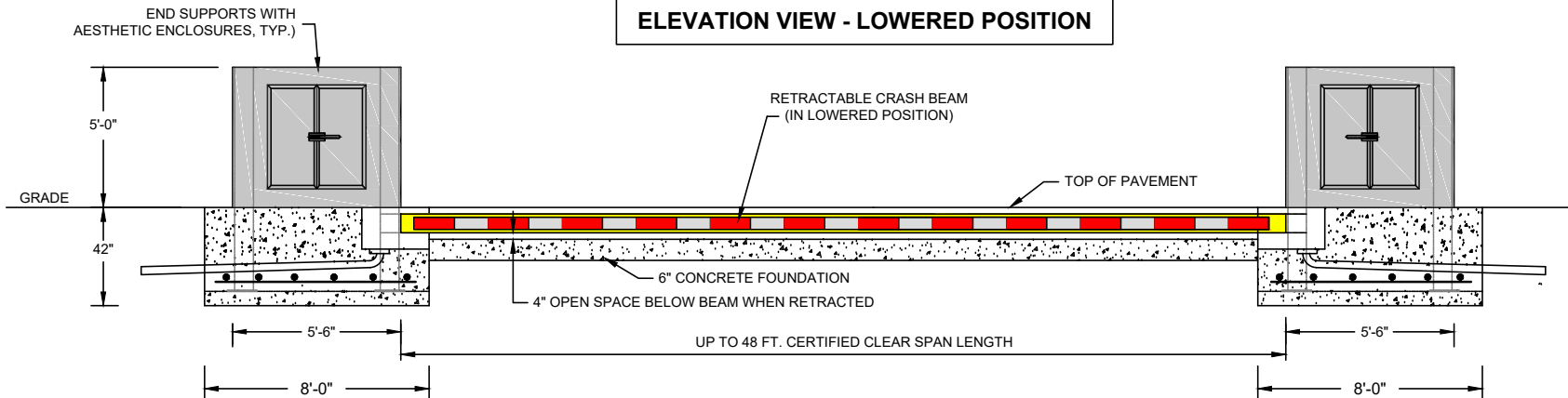

BARRIER1 SYSTEMS, INC.

8015 THORNDIKE ROAD
GREENSBORO, NC 27409
(336) 617-8478 (336) 617-8471 FAX
miamore@barrier1.us www.barrier1.us

THE DRAWINGS AND INFORMATION CONTAINED HEREIN ARE PROPRIETARY AND CONFIDENTIAL, AND FOR USE BY ONLY PERSONS WORKING ON PROJECT WITH BARRIER1 SYSTEMS, INC. DO NOT COPY OR REPRODUCE. ALL RIGHTS RESERVED.

GROUND RETRACTABLE
FINAL DENIAL CRASH BEAM
ELECTRICALLY OPERATED

SAMPLE DRAWINGS

SHEET: 2 OF 10

06222017

SCALE: N.T.S.

GROUND RETRACTABLE CRASH BEAM - MODEL HCB-EL-400 (ELECTRICALLY OPERATED, REDUCED RISK)

STOPS 15,000 LB. VEHICLE AT 30 MPH IMPACT (BARRIER CERTIFIED UP TO 48 FEET CLEAR SPAN LENGTHS)

ASTM F2656-07 M30(K4) CERTIFIED, APPROVED BY DoD AND ON ANTI-RAM LIST

TYPICAL SECTIONS AND DETAILS

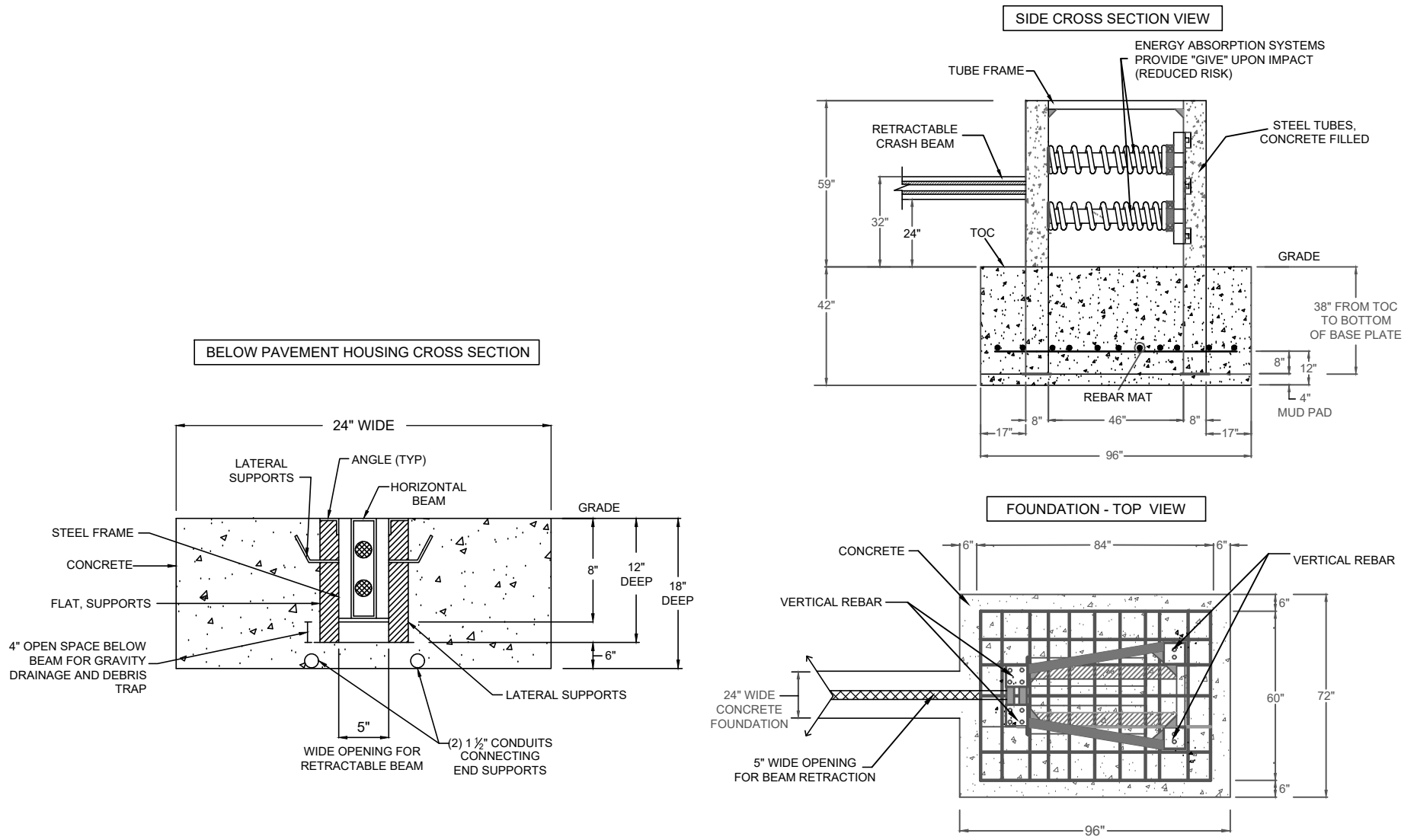

BARRIER1 SYSTEMS, INC.

8015 THORNDIKE ROAD
GREENSBORO, NC 27409
(336) 617-8478 (336) 617-8471 FAX
miamore@barrier1.us www.barrier1.us

THE DRAWINGS AND INFORMATION CONTAINED HEREIN ARE PROPRIETARY AND CONFIDENTIAL, AND FOR USE BY ONLY PERSONS WORKING ON PROJECT WITH BARRIER1 SYSTEMS, INC. DO NOT COPY OR REPRODUCE. ALL RIGHTS RESERVED.

**GROUND RETRACTABLE
FINAL DENIAL CRASH BEAM
ELECTRICALLY OPERATED**

SAMPLE DRAWINGS

SHEET: 3 OF 10

06222017

SCALE: N.T.S.

GROUND RETRACTABLE CRASH BEAM - MODEL HCB-EL-400 (ELECTRICALLY OPERATED, REDUCED RISK)

STOPS 15,000 LB. VEHICLE AT 30 MPH IMPACT (BARRIER CERTIFIED UP TO 48 FEET CLEAR SPAN LENGTHS)

ASTM F2656-07 M30(K4) CERTIFIED, APPROVED BY DoD AND ON ANTI-RAM LIST

MAIN CONTROLLERS

SAMPLE MAIN CONTROL PANEL

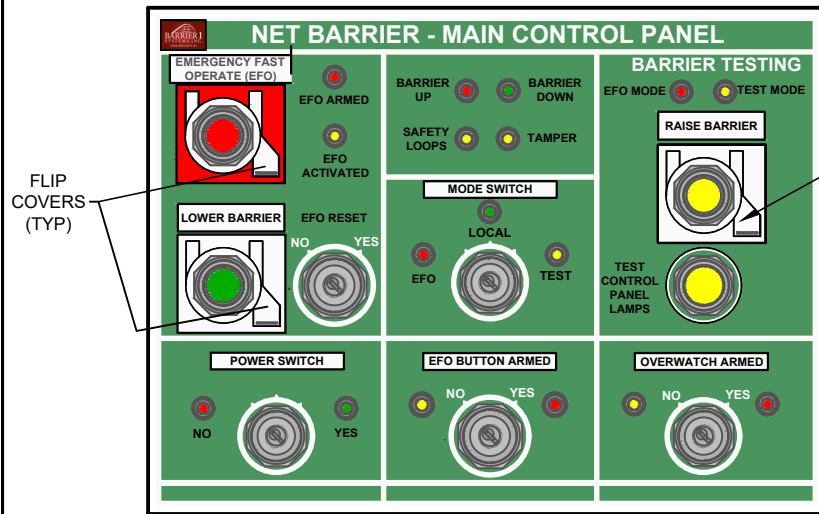

SAMPLE CONTROL PANEL AT OVERWATCH

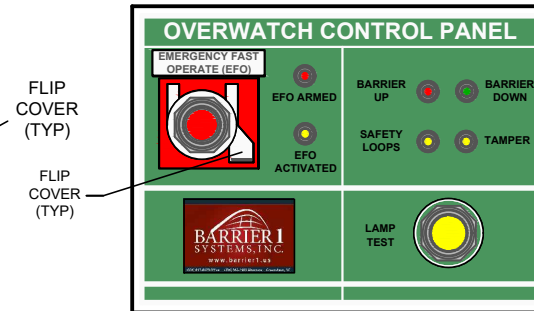

REMOTE EFO BUTTON(S) TO DEPLOY NET (EMERGENCY FAST OPERATION)

LOCATED WHERE NEEDED

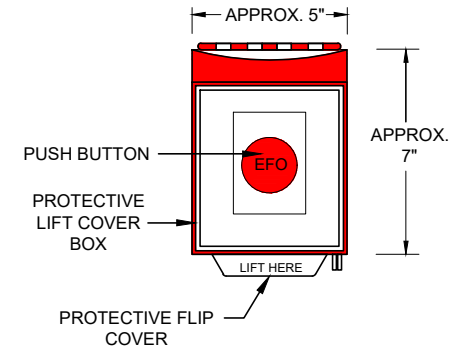

KEY CAPABILITIES

1. CONTROL PANELS, ALARMS, KEYED SWITCHES, AND OTHER FEATURES ARE CUSTOMIZED BY BARRIER1 SYSTEMS IN ACCORDANCE WITH CUSTOMER'S NEEDS.
2. DATA LOGGER IS INCLUDED WHICH RECORDS THE DATE, TIME, AND LOCATION OF EACH NET BARRIER DEPLOYMENT.
3. UPS BATTERY BACKUP IS PROVIDED FOR ALL CONTROLS AND SYSTEMS DURING POWER OUTAGE.
4. IF VEHICLE SITS ON LOOP FOR 12 SECONDS, INDICATOR LIGHT ACTIVATES. THIS ACTIVATION TIME CAN BE ADJUSTED.
5. TAMPER SWITCH MONITORS DOOR OPENINGS ON AESTHETIC END SUPPORT ENCLOSURES AND PLC CABINET DOOR.
6. WHEN DOING MAINTENANCE, PLACE IN "LOCAL MODE" SO BARRIER DEPLOYMENT IS LOCKED OUT AT GUARD HOUSE AND OVERWATCH. NET CAN BE DEPLOYED LOCALLY AT BARRIER ONLY.

MILITARY GRADE,
1,500+ FOOT RANGE
LINE OF SIGHT

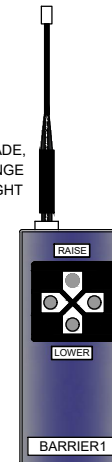

OPTIONAL REMOTE WIRELESS CONTROLLER



BARRIER1 SYSTEMS, INC.

8015 THORNDIKE ROAD
GREENSBORO, NC 27409
(336) 617-8478 (336) 617-8471 FAX
miamore@barrier1.us www.barrier1.us

THE DRAWINGS AND INFORMATION CONTAINED HEREIN ARE PROPRIETARY AND CONFIDENTIAL, AND FOR USE BY ONLY PERSONS WORKING ON PROJECT WITH BARRIER1 SYSTEMS, INC. DO NOT COPY OR REPRODUCE. ALL RIGHTS RESERVED.

GROUND RETRACTABLE
FINAL DENIAL CRASH BEAM
ELECTRICALLY OPERATED

SAMPLE DRAWINGS

SHEET: 4 OF 10

06222017

SCALE: N.T.S.

GROUND RETRACTABLE CRASH BEAM - MODEL HCB-EL-400 (ELECTRICALLY OPERATED, REDUCED RISK)

STOPS 15,000 LB. VEHICLE AT 30 MPH IMPACT (BARRIER CERTIFIED UP TO 48 FEET CLEAR SPAN LENGTHS)

ASTM F2656-07 M30(K4) CERTIFIED, APPROVED BY DoD AND ON ANTI-RAM LIST

SIGNS AND SIGNALS (LOW VOLTAGE)

KEY CAPABILITIES:

1. UPS BATTERY BACKUP POWER PROVIDED FOR ALL LIGHTS, SIGNALS, CONTROL PANELS, DEVICES, ETC. IF POWER OUTAGE OCCURS.
2. TRAFFIC SIGNAL AND "BARRIER SIGNAL" SIGN INSTALLED ON POLE AND/OR MAST ARM.
3. SIGNS ARE DIAMOND GRADE AND RETRO REFLECTIVE.

ELEVATION VIEWS

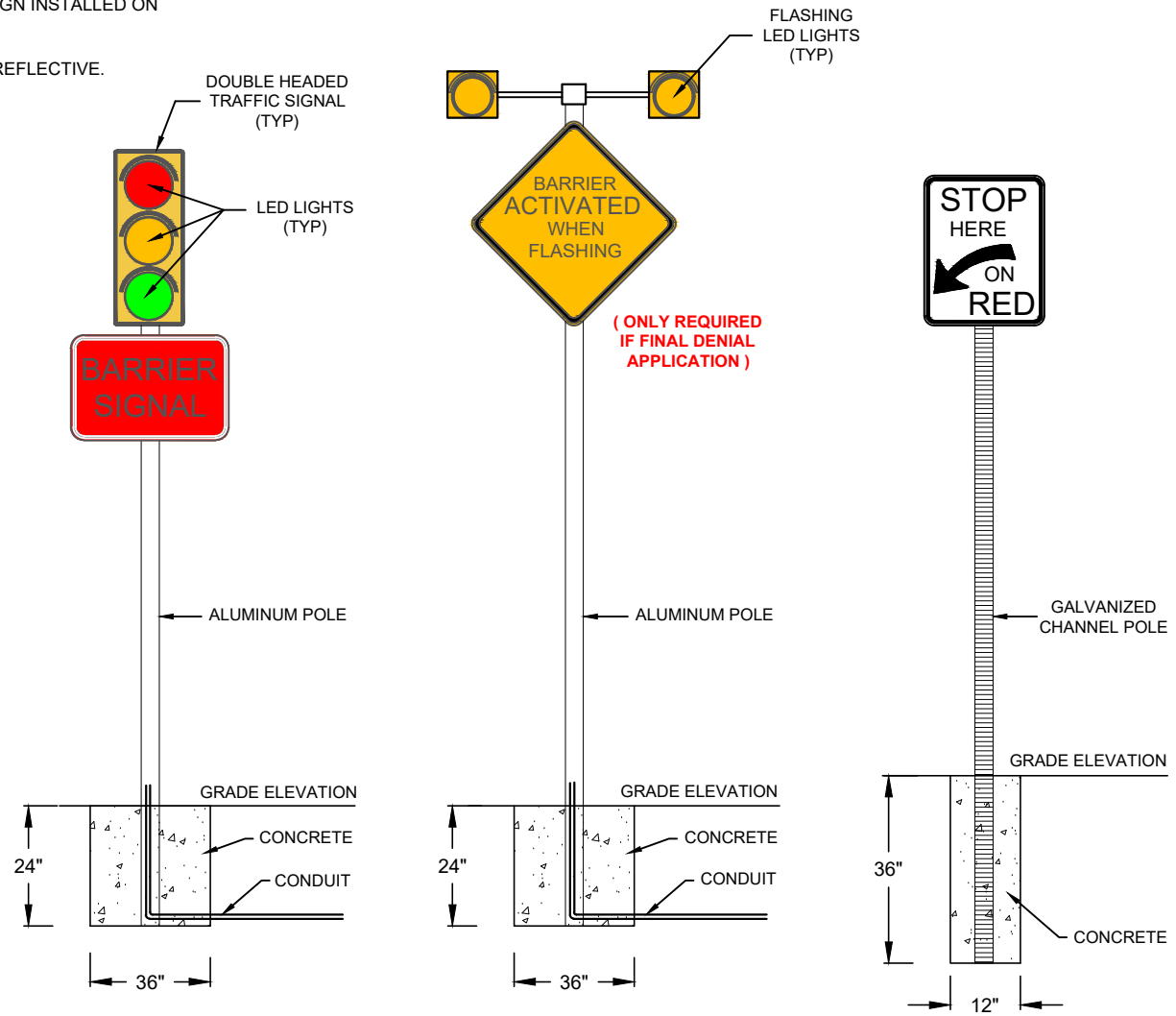

BARRIER1 SYSTEMS, INC.

8015 THORNDIKE ROAD
GREENSBORO, NC 27409
(336) 617-8478 (336) 617-8471 FAX
miamore@barrier1.us www.barrier1.us

THE DRAWINGS AND INFORMATION CONTAINED HEREIN ARE PROPRIETARY AND CONFIDENTIAL, AND FOR USE BY ONLY PERSONS WORKING ON PROJECT WITH BARRIER1 SYSTEMS, INC. DO NOT COPY OR REPRODUCE. ALL RIGHTS RESERVED.

RETRACTABLE HORIZONTAL
FINAL DENIAL CRASH BEAM
ELECTRICALLY OPERATED

SAMPLE DRAWINGS

SHEET: 5 OF 10

06222017

SCALE: N.T.S.

GROUND RETRACTABLE CRASH BEAM - MODEL HCB-EL-400 (ELECTRICALLY OPERATED, REDUCED RISK)

STOPS 15,000 LB. VEHICLE AT 30 MPH IMPACT (BARRIER CERTIFIED UP TO 48 FEET CLEAR SPAN LENGTHS)

ASTM F2656-07 M30(K4) CERTIFIED, APPROVED BY DoD AND ON ANTI-RAM LIST

CONDUIT SCHEMATIC

PLAN VIEW

CONDUIT SIZE	LINE COLOR
3/4"	- - - - -
1"	- - - - -
1 1/2"	- - - - -

SYMBOL LEGEND	
[TS]	= TRAFFIC SIGNAL
[WL]	= WARNING LIGHTS

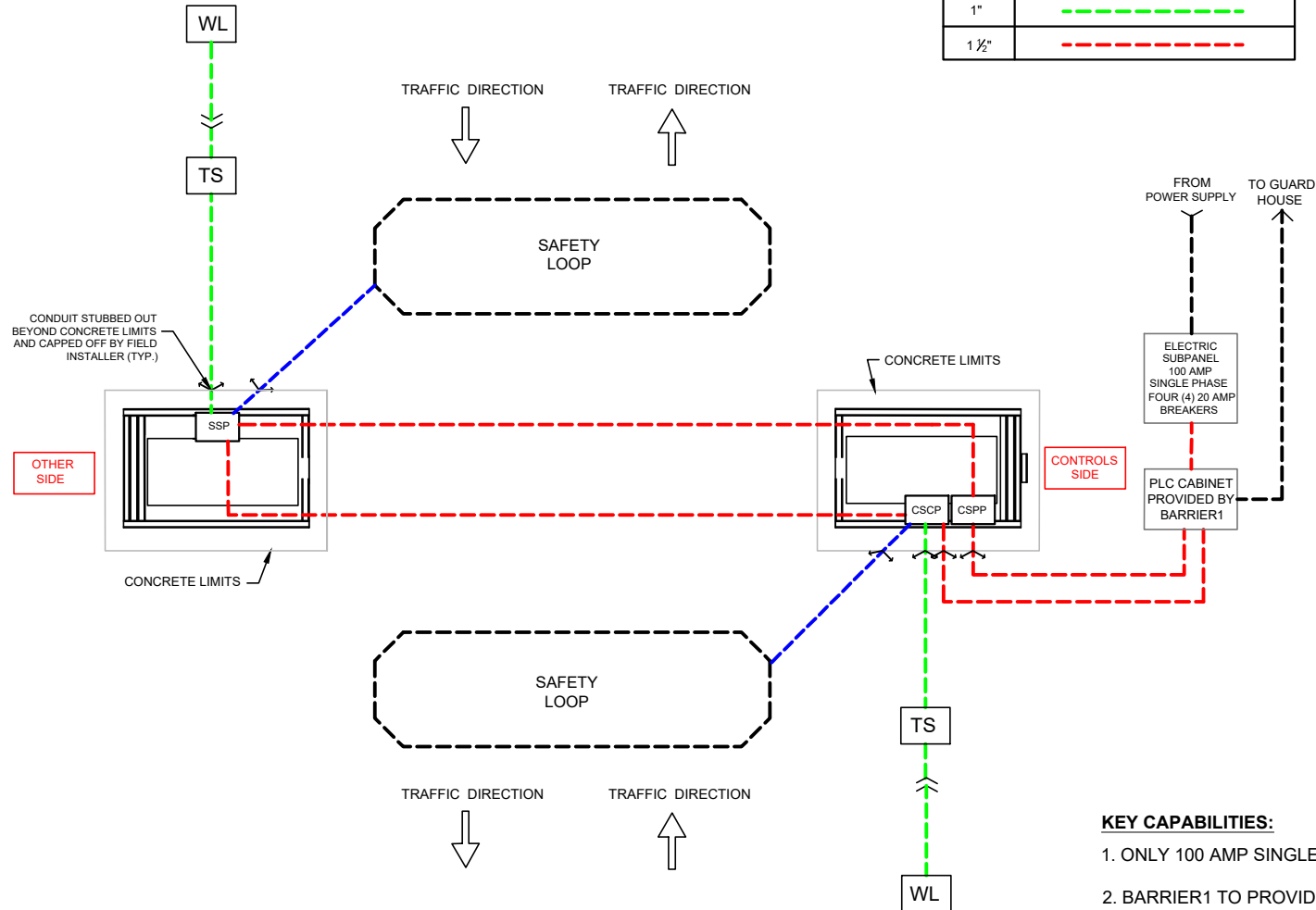

KEY CAPABILITIES:

1. ONLY 100 AMP SINGLE PHASE POWER SUPPLY REQUIRED (TYP.)
2. BARRIER1 TO PROVIDE LOW VOLTAGE WIRE.
3. DETAILED WIRING DIAGRAMS TO BE PROVIDED.



BARRIER1 SYSTEMS, INC.

8015 THORNDIKE ROAD
GREENSBORO, NC 27409
(336) 617-8478 (336) 617-8471 FAX
miamore@barrier1.us www.barrier1.us

THE DRAWINGS AND INFORMATION CONTAINED HEREIN ARE PROPRIETARY AND CONFIDENTIAL, AND FOR USE BY ONLY PERSONS WORKING ON PROJECT WITH BARRIER1 SYSTEMS, INC. DO NOT COPY OR REPRODUCE. ALL RIGHTS RESERVED.

GROUND RETRACTABLE
FINAL DENIAL CRASH BEAM
ELECTRICALLY OPERATED

SAMPLE DRAWINGS

SHEET: 6 OF 10

06222017

SCALE: N.T.S.

GROUND RETRACTABLE CRASH BEAM - MODEL HCB-EL-400 (ELECTRICALLY OPERATED, REDUCED RISK)

STOPS 15,000 LB. VEHICLE AT 30 MPH IMPACT (BARRIER CERTIFIED UP TO 48 FEET CLEAR SPAN LENGTHS)

ASTM F2656-07 M30(K4) CERTIFIED, APPROVED BY DoD AND ON ANTI-RAM LIST

SEQUENCING OF TRAFFIC SIGNALS, WARNING LIGHTS, AND ALARMS UPON ACTIVATION

(ONLY APPLIES IF FINAL DENIAL APPLICATION)

TRAFFIC CONTROLS AND SAFETY AT ACTIVE BARRIERS	OPERATIONAL SEQUENCE PER SECOND (MIN. FOR SAFETY - 40 KPH (25 MPH) DESIGN SPEED)											
	ELAPSED TIME	0	1 SEC.	2 SEC.	3 SEC.	4 SEC.	5 SEC.	6 SEC.	7 SEC.	8 SEC.	9 SEC.	10 SEC.
TRAFFIC CONTROLS	NORMAL OPS	GUARD PERCEPTION AND REACTION TIME TO THREAT (EFO BUTTON) - 3 SECONDS				YELLOW CLEARANCE - GET ACROSS BARRIER 3 SECONDS (MUTCD MINIMUM)			ALL RED	DEPLOYING BARRIER		THREAT CONTAINED
SIGN AND SIGNAL WARNING SYSTEM	WARNING SIGNS AND LIGHTS WITH BEACONS	OFF	OFF	OFF	OFF	ALT FY	ALT FY	ALT FY	ALT FY	ALT FY	ALT FY	ALT FY
	TRAFFIC SIGNAL	FY OR G	FY OR G	FY OR G	FY OR G	Y	Y	Y	R	R	R	R
	AUDIBLE SIREN ALARM	OFF	OFF	OFF	OFF	ON	ON	ON	ON	ON	ON	ON
	SAFETY LOOP DETECTORS	ON	ON	ON	ON	ON	ON	ON	ON	ON	ON	ON
	ACTIVE BARRIER POSITION	DOWN	DOWN	DOWN	DOWN	DOWN	DOWN	DOWN	DOWN	DOWN	ACTIVATED	ACTIVATED

KEY:

R = RED

Y = YELLOW

G = GREEN

FY = FLASHING YELLOW

ALT = ALTERNATING

KEY CAPABILITIES:

1. SEQUENCING AND TIMING OF SIGNALS, ALARMS AND LIGHTS CAN BE FIELD ADJUSTED USING PLC.
2. SAFETY LOOP DETECTORS PREVENT DEPLOYMENT OF BARRIER IF A VEHICLE IS ABOVE LOOP. BARRIER DEPLOYS AFTER VEHICLE PASSES OVER THE SAFETY LOOPS.



BARRIER1 SYSTEMS, INC.

8015 THORNDIKE ROAD
GREENSBORO, NC 27409
(336) 617-8478 (336) 617-8471 FAX
miamore@barrier1.us www.barrier1.us

THE DRAWINGS AND INFORMATION CONTAINED HEREIN ARE PROPRIETARY AND CONFIDENTIAL, AND FOR USE BY ONLY PERSONS WORKING ON PROJECT WITH BARRIER1 SYSTEMS, INC. DO NOT COPY OR REPRODUCE. ALL RIGHTS RESERVED.

GROUND RETRACTABLE
FINAL DENIAL CRASH BEAM
ELECTRICALLY OPERATED

SAMPLE DRAWINGS

SHEET: 7 OF 10

06222017

SCALE: N.T.S.

GROUND RETRACTABLE CRASH BEAM - MODEL HCB-EL-400 (ELECTRICALLY OPERATED, REDUCED RISK)

STOPS 15,000 LB. VEHICLE AT 30 MPH IMPACT (BARRIER CERTIFIED UP TO 48 FEET CLEAR SPAN LENGTHS)

ASTM F2656-07 M30(K4) CERTIFIED, APPROVED BY DoD AND ON ANTI-RAM LIST

LOCAL CONTROLLERS LOCKED INSIDE CONTROLS SIDE END SUPPORT ENCLOSURE

(USED WHEN DOING MAINTENANCE)

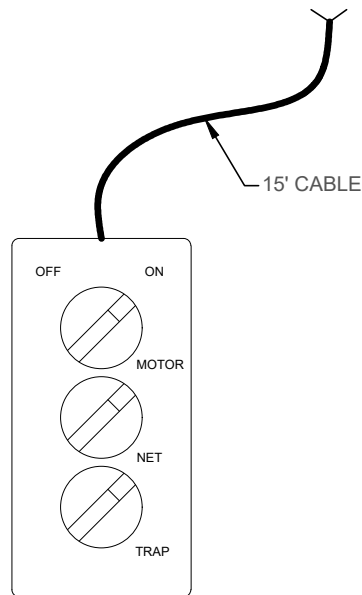

MAINTENANCE CONTROLLER

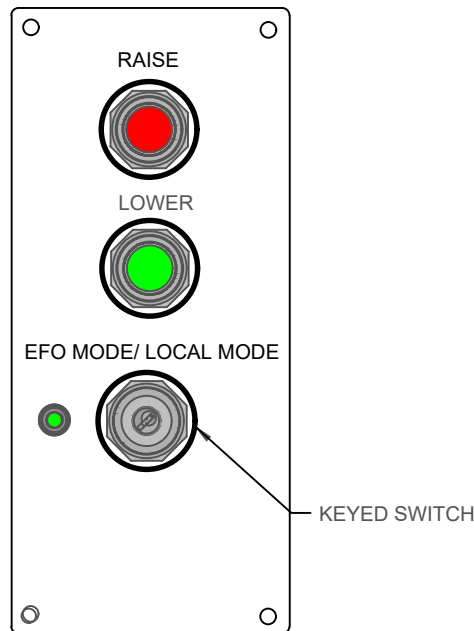

LOCAL CONTROLLER

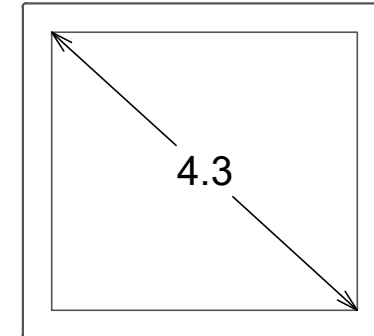

OPTIONAL TOUCH SCREEN LOCAL CONTROLLER

PROGRAMMABLE TOUCH SCREEN WITH ICONS



BARRIER1 SYSTEMS, INC.

8015 THORNDIKE ROAD
GREENSBORO, NC 27409
(336) 617-8478 (336) 617-8471 FAX
miamore@barrier1.us www.barrier1.us

THE DRAWINGS AND INFORMATION CONTAINED HEREIN ARE PROPRIETARY AND CONFIDENTIAL, AND FOR USE BY ONLY PERSONS WORKING ON PROJECT WITH BARRIER1 SYSTEMS, INC. DO NOT COPY OR REPRODUCE. ALL RIGHTS RESERVED.

GROUND RETRACTABLE
FINAL DENIAL CRASH BEAM
ELECTRICALLY OPERATED

SAMPLE DRAWINGS

SHEET: 8 OF 10

06222017

SCALE: N.T.S.

GROUND RETRACTABLE CRASH BEAM - MODEL HCB-EL-400 (ELECTRICALLY OPERATED, REDUCED RISK)

STOPS 15,000 LB. VEHICLE AT 30 MPH IMPACT (BARRIER CERTIFIED UP TO 48 FEET CLEAR SPAN LENGTHS)

ASTM F2656-07 M30(K4) CERTIFIED, APPROVED BY DoD AND ON ANTI-RAM LIST

AESTHETIC LOCKING ENCLOSURES OVER END SUPPORTS NON-RUSTING ALUMINUM COVERS

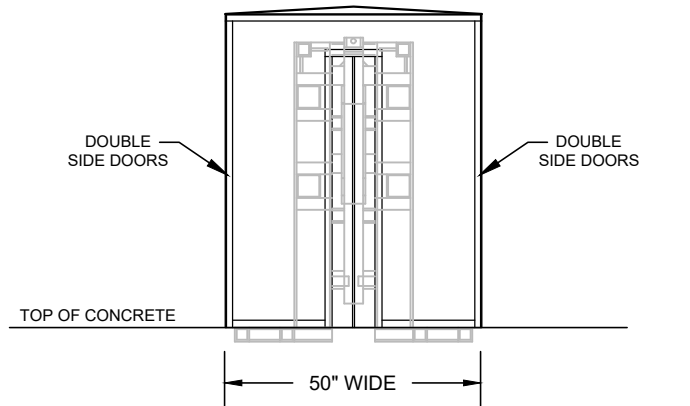

FRONT SIDE

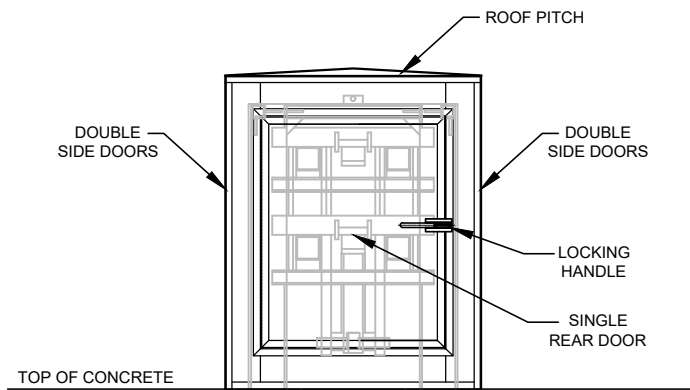

REAR SIDE

OPTIONAL DAY/NIGHT CAMERA WITH CONTINUOUS DVR RECORDING TO VIDEO TAPE INCIDENTS

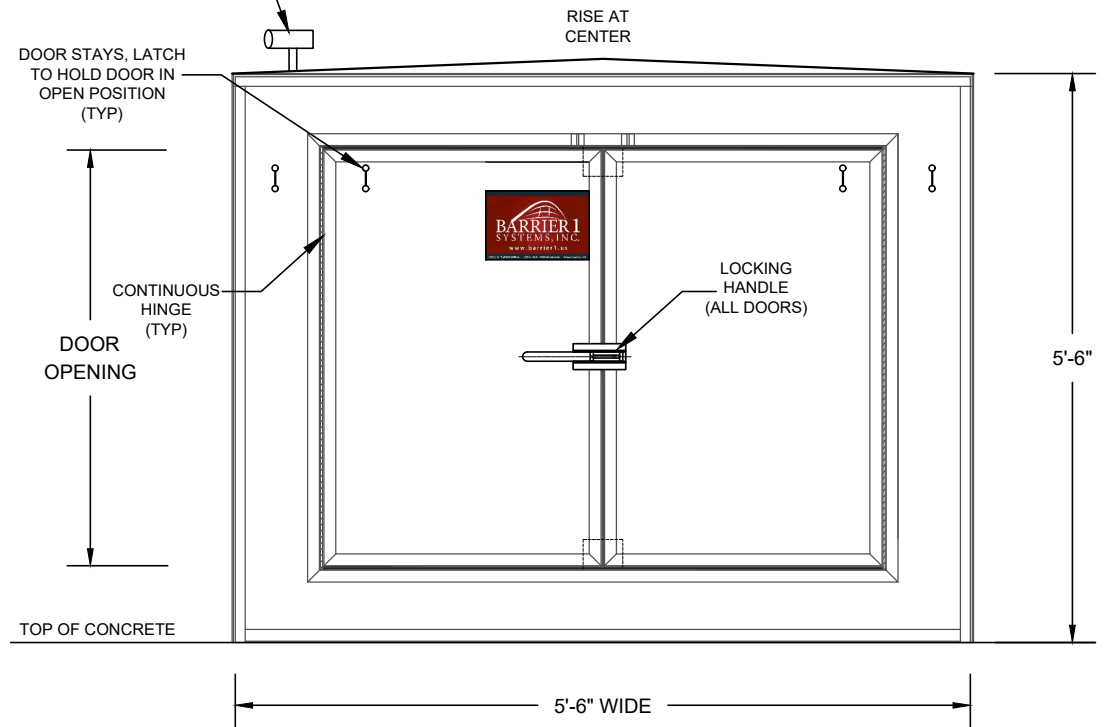

SIDE VIEW

KEY CAPABILITIES:

1. WEATHER SEAL WITH GASKETS ON DOOR OPENINGS. (OPTIONAL)
2. INSULATED ENCLOSURE WITH THERMOSTAT CONTROLLED HEATERS. (OPTIONAL)
3. COMPONENTS AND ELECTRONICS SENSITIVE TO WATER ARE 8" MINIMUM OFF TOP OF CONCRETE.
4. ENCLOSURES HAVE DOUBLE DOORS ON BOTH SIDES, AND SINGLE DOOR IN REAR.



BARRIER1 SYSTEMS, INC.

8015 THORNDIKE ROAD
GREENSBORO, NC 27409
(336) 617-8478 (336) 617-8471 FAX
miamore@barrier1.us www.barrier1.us

THE DRAWINGS AND INFORMATION CONTAINED HEREIN ARE PROPRIETARY AND CONFIDENTIAL, AND FOR USE BY ONLY PERSONS WORKING ON PROJECT WITH BARRIER1 SYSTEMS, INC. DO NOT COPY OR REPRODUCE. ALL RIGHTS RESERVED.

GROUND RETRACTABLE
FINAL DENIAL CRASH BEAM
ELECTRICALLY OPERATED

SAMPLE DRAWINGS

SHEET: 9 OF 10

06222017

SCALE: N.T.S.

GROUND RETRACTABLE CRASH BEAM - MODEL HCB-EL-400 (ELECTRICALLY OPERATED, REDUCED RISK)

STOPS 15,000 LB. VEHICLE AT 30 MPH IMPACT (BARRIER CERTIFIED UP TO 48 FEET CLEAR SPAN LENGTHS)

ASTM F2656-07 M30(K4) CERTIFIED, APPROVED BY DoD AND ON ANTI-RAM LIST

OPTIONAL ITEMS

1. CARD READERS AND/OR KEY PADS.
2. CAMERAS WITH CONTINUOUS DVR RECORDING TO VIDEO TAPE INCIDENTS.
3. UPS BACKUP POWER (PROVIDES 10+ CYCLES, OVER 2 HOURS IF POWER OUTAGE OCCURS).
4. ADDITIONAL TRAFFIC SIGNS, AUDIBLE ALARMS, AND/OR WARNING LIGHTS.
5. TAMPER ALARMS ON DOORS AND CABINETS.
6. REMOTE WIRELESS CONTROLLER(S) TO RAISE OR LOWER WEDGE BARRIER.
7. TRIGGER LOOPS AND/OR RFID TAGS TO RAISE OR LOWER BARRIER ARM.
8. STAINLESS STEEL MATERIALS AND COMPONENTS.
9. SPECIALTY PAINTING, PLACARDS, AND DETAILING.
10. OVER SPEED DETECTION AND EARLY WARNING ALARMS.
11. WRONG WAY DETECTION AND ALARMS.
12. TOUCH SCREEN CONTROLLERS WITH ICONS FOR GUARD HOUSE, OVER WATCH, AND LOCAL CONTROLLER.
13. CRASH RATED BOLLARDS AND COVERS. (ASTM M30 (K4), M40 (K8) AND M50 (K12)).
14. CORRIDOR CABLE FENCING FROM ACP TO BARRIER LOCATION (PREVENTS VEHICLES FROM GOING AROUND BARRIER).
15. COLD WEATHER PACKAGE INCLUDES THERMOSTAT CONTROLLED SPACE HEATER, INSULATED ENCLOSURE FOR CONTROLS SIDE, WEATHERSEAL WITH GASKETS ON ENCLOSURE DOORS, AND THERMOSTAT CONTROLLED HEATER WIRE FOR BELOW PAVEMENT HOUSING.



BARRIER1 SYSTEMS, INC.

8015 THORNDIKE ROAD
GREENSBORO, NC 27409
(336) 617-8478 (336) 617-8471 FAX
miamore@barrier1.us www.barrier1.us

THE DRAWINGS AND INFORMATION CONTAINED HEREIN ARE PROPRIETARY AND CONFIDENTIAL, AND FOR USE BY ONLY PERSONS WORKING ON PROJECT WITH BARRIER1 SYSTEMS, INC. DO NOT COPY OR REPRODUCE. ALL RIGHTS RESERVED.

GROUND RETRACTABLE
FINAL DENIAL CRASH BEAM
ELECTRICALLY OPERATED

SAMPLE DRAWINGS

SHEET: 10 OF 10

06222017

SCALE: N.T.S.