

**ELECTRIC CRASH BEAM- MODEL FCB-1200, ASTM M50 CRASH RATED**  
 CRASH RATED AND CERTIFIED TO STOP 15,000 LBS. IMPACT AT 50 MPH

**PROPRIETARY AND CONFIDENTIAL**  
**PATENT PROTECTED**

DO NOT COPY OR REPRODUCE. FOR USE WORKING WITH BARRIER1 SYSTEMS ONLY

**PRELIMINARY DRAWING**

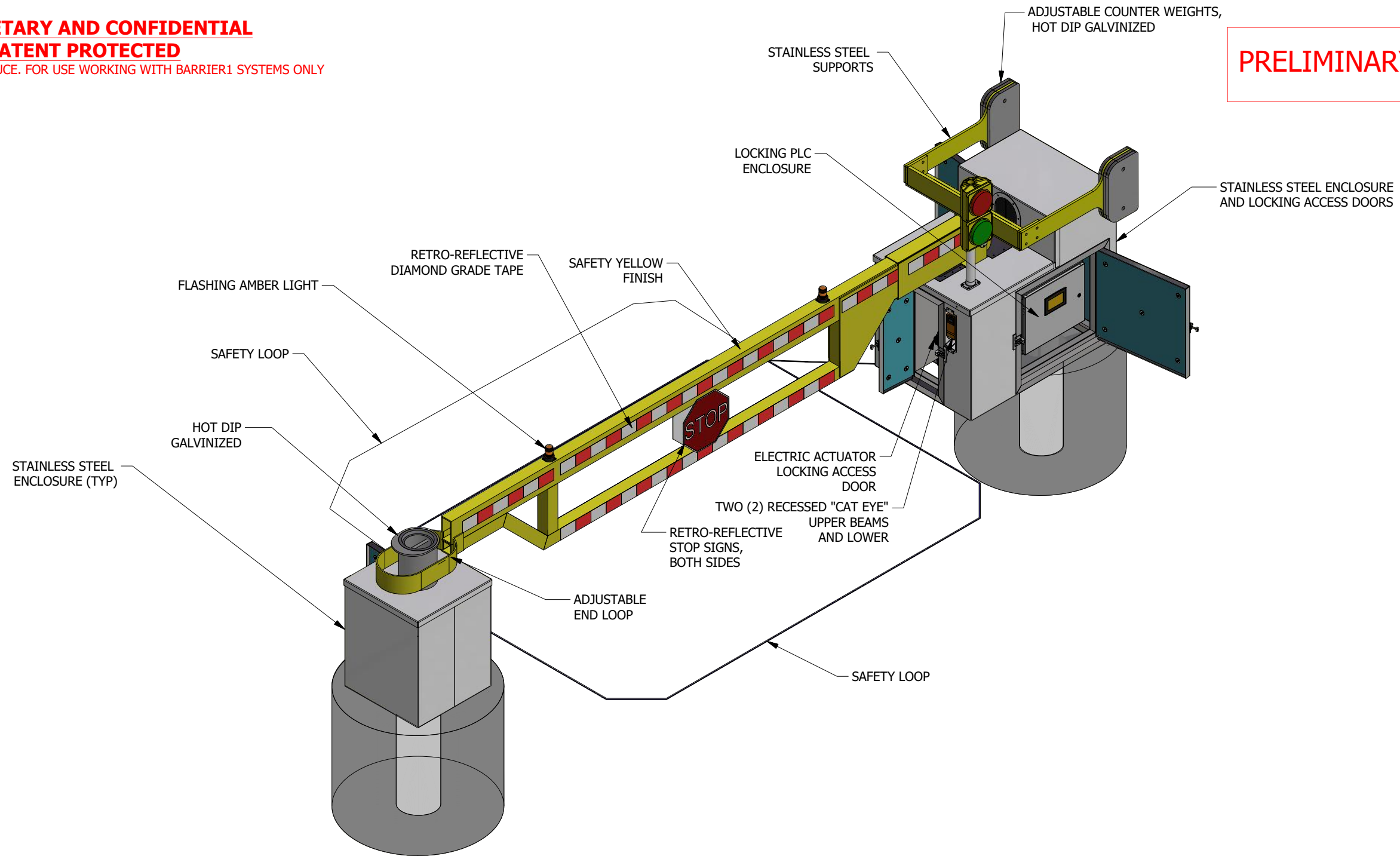

**BARRIER1 SYSTEMS, INC.**  
 8015 THORNDIKE ROAD  
 GREENSBORO, NC 27409  
 (336) 617-8478 (336) 617-471 FAX  
 mlamore@barrier1.us www.barrier1.us

**PATENT PROTECTED**  
 THE DRAWINGS AND INFORMATION CONTAINED HEREIN ARE  
 PROPRIETARY AND CONFIDENTIAL AND FOR USE ONLY BY  
 PERSONS WORKING ON PROJECT WITH BARRIER1 SYSTEMS, INC.  
 DO NOT COPY OR REPRODUCE. ALL RIGHTS RESERVED

ITEM / PAGE 1 OF 8  
 NOV. 14, 2019  
 SCALE: N.T.S.

# ELECTRIC CRASH BEAM- MODEL FCB-1200, ASTM M50 CRASH RATED

CRASH RATED AND CERTIFIED TO STOP 15,000 LBS. IMPACT AT 50 MPH

**PROPRIETARY AND CONFIDENTIAL  
PATENT PROTECTED**

DO NOT COPY OR REPRODUCE. FOR USE WORKING WITH BARRIER1 SYSTEMS ONLY

**PRELIMINARY DRAWING**

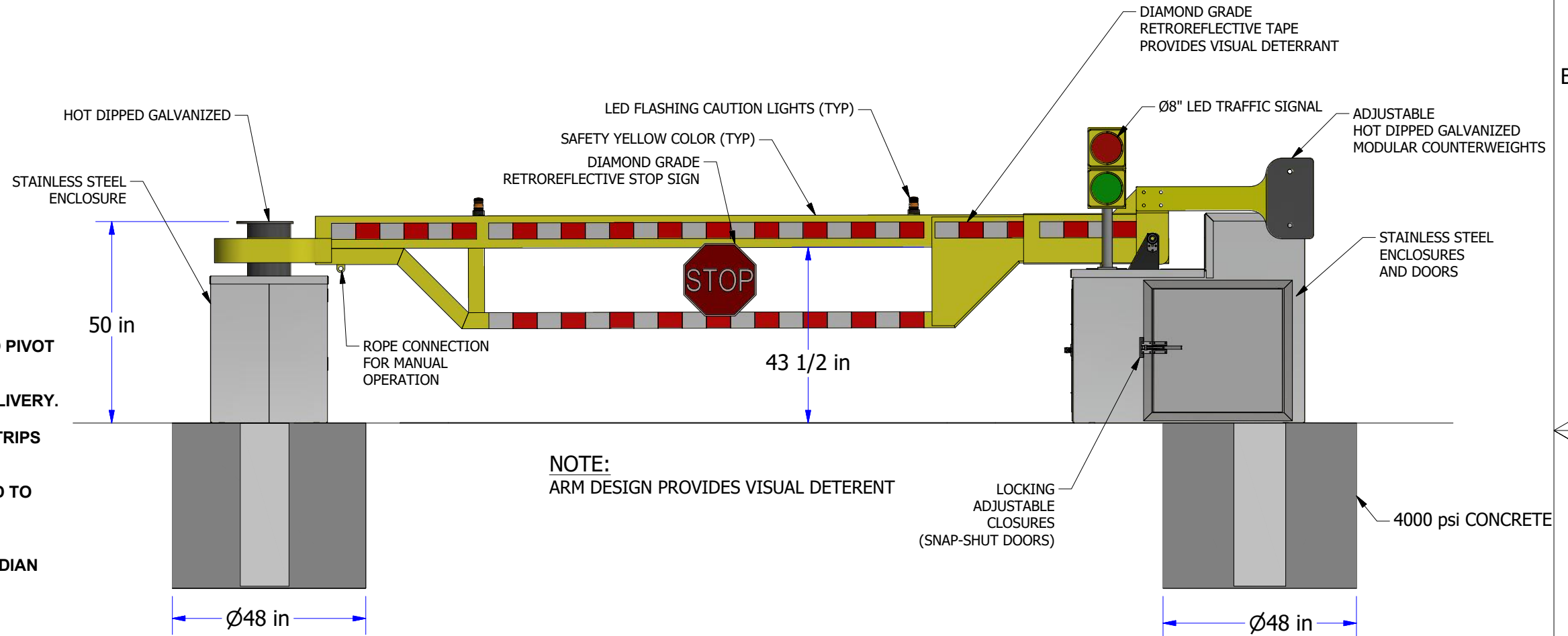

**KEY CAPABILITIES:**

1. RAISE OR LOWER ARM IN ABOUT 4 SECONDS. HOOK SIDE AND PIVOT SIDE OF BARRIER CAN BE REVERSED.
2. BARRIER IS PREFABRICATED AND PRE-ASSEMBLED UPON DELIVERY.
3. BARRIER ARM IS HIGHLY VISIBLE WITH RETRO-REFLECTIVE STRIPS AND SIGNS, AND PROVIDES A VISUAL DETERRENT.
4. BI-DIRECTIONAL STOPPING CAPABILITY. (ASTM M50 CERTIFIED TO STOP INBOUND AND OUTBOUND VERTICAL IMPACTS) STOPS 15,000 LB. VEHICLE AT 50 MPH WITH 1.9 METER PENETRATION.
5. ROBUST ELECTRICAL ACTUATOR WITH WATER PROOF ACCORDIAN COVERING ROD, IP67 RATING.
6. AUTOMATIC ELECTRIC LOCKING IN DOWN POSITION. MANUAL LOCKING ALSO PROVIDED.
7. MANUALLY OPERATE BARRIER ARM BY ONE (1) PERSON IF OUT OF SERVICE.
8. UNAFFECTED BY GRADE ELEVATION DIFFERENCES ON SIDES OF ROADWAY.
9. ALL MATERIALS ARE RUST INHIBITING, INCLUDING STAINLESS STEEL, ALUMINUM WITH INDUSTRIAL PAINT COAT, AND HOT DIPPED GALVANIZED STEEL.
10. SAFETY LOOP AND TWO (2) LIGHT SENSORS PROVIDE REDUNDANCY AGAINST DROP ARM BEING LOWERED ON TOP OF VEHICLE.
11. MODULAR COMPONENTS ALLOW FOR EASY REPLACEMENT OF PARTS.
12. REDUCED MAINTENANCE. REMOTE ACCESS OF ACTUATOR SETTINGS FROM ANYWHERE, USING WIRELESS HOT SPOT.
13. UPS BACKUP POWER AVAILABLE.
14. MINIMAL MAINTENANCE.

**NOTE:**  
ARM DESIGN PROVIDES VISUAL DETERRENT



**BARRIER1 SYSTEMS, INC.**  
8015 THORNDIKE ROAD  
GREENSBORO, NC 27409  
(336) 617-8478 (336) 617-471 FAX  
mlamore@barrier1.us www.barrier1.us

**PATENT PROTECTED**  
THE DRAWINGS AND INFORMATION CONTAINED HEREIN ARE PROPRIETARY AND CONFIDENTIAL AND FOR USE ONLY BY PERSONS WORKING ON PROJECT WITH BARRIER1 SYSTEMS, INC. DO NOT COPY OR REPRODUCE. ALL RIGHTS RESERVED

ITEM / PAGE 2 OF 8  
NOV. 14, 2019  
SCALE: N.T.S.

**ELECTRIC CRASH BEAM- MODEL FCB-1200, ASTM M50 CRASH RATED**  
 CRASH RATED AND CERTIFIED TO STOP 15,000 LBS. IMPACT AT 50 MPH

**PROPRIETARY AND CONFIDENTIAL**  
**PATENT PROTECTED**  
 DO NOT COPY OR REPRODUCE. FOR USE WORKING WITH BARRIER1 SYSTEMS ONLY

**PRELIMINARY DRAWING**

ARM OPEN

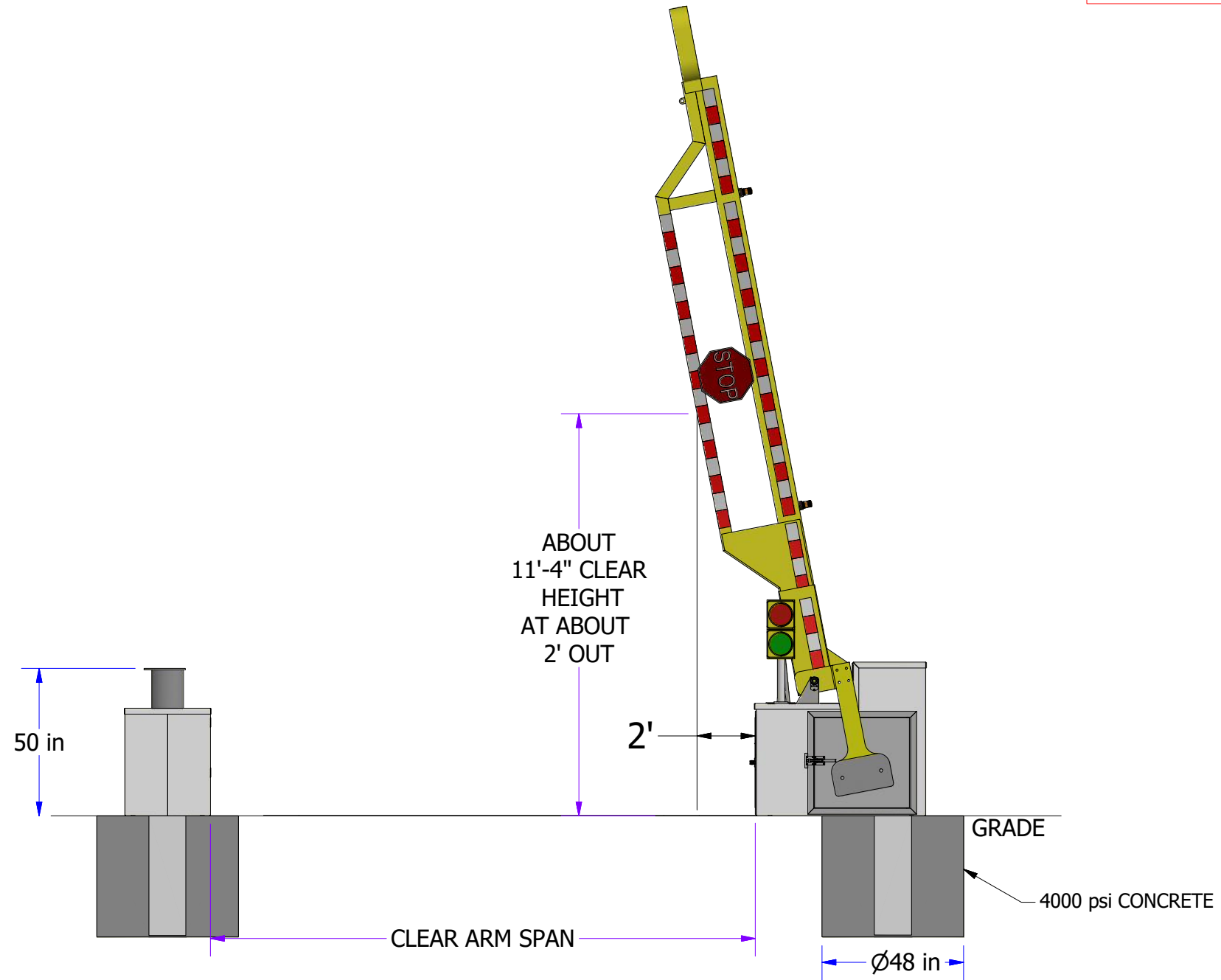

**BARRIER1 SYSTEMS, INC.**  
 8015 THORNDIKE ROAD  
 GREENSBORO, NC 27409  
 (336) 617-8478 (336) 617-471 FAX  
 mlamore@barrier1.us www.barrier1.us

**PATENT PROTECTED**  
 THE DRAWINGS AND INFORMATION CONTAINED HEREIN ARE  
 PROPRIETARY AND CONFIDENTIAL AND FOR USE ONLY BY  
 PERSONS WORKING ON PROJECT WITH BARRIER1 SYSTEMS, INC.  
 DO NOT COPY OR REPRODUCE. ALL RIGHTS RESERVED

ITEM / PAGE 3 OF 8  
 NOV. 14, 2019  
 SCALE: N.T.S.

**ELECTRIC CRASH BEAM- MODEL FCB-1200, ASTM M50 CRASH RATED**  
 CRASH RATED AND CERTIFIED TO STOP 15,000 LBS. IMPACT AT 50 MPH

**PROPRIETARY AND CONFIDENTIAL**  
**PATENT PROTECTED**

DO NOT COPY OR REPRODUCE. FOR USE WORKING WITH BARRIER1 SYSTEMS ONLY

**MANUAL OPERATIONS**

**PRELIMINARY DRAWING**

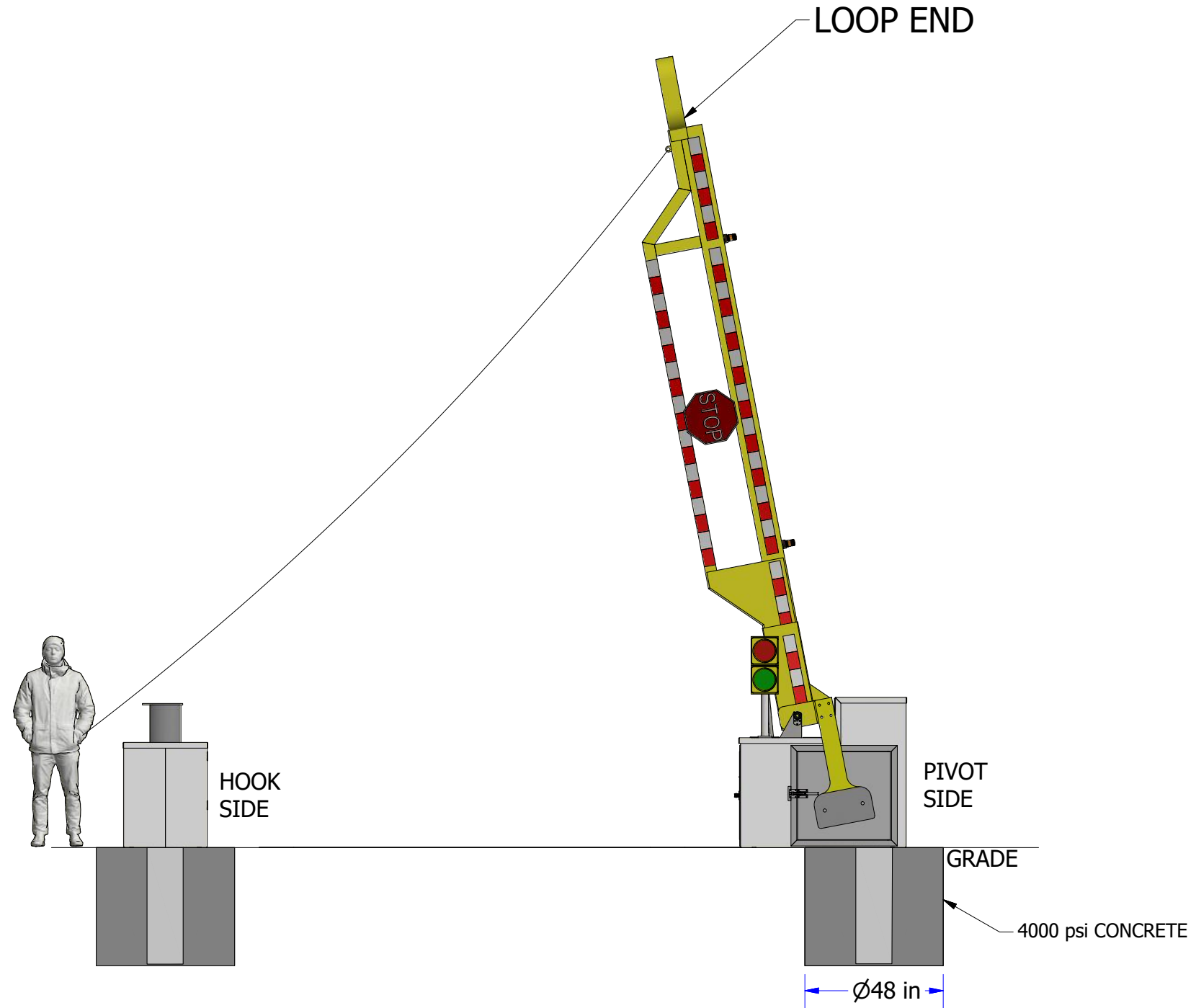

**BARRIER1 SYSTEMS, INC.**  
 8015 THORNDIKE ROAD  
 GREENSBORO, NC 27409  
 (336) 617-8478 (336) 617-471 FAX  
 mlamore@barrier1.us www.barrier1.us

**PATENT PROTECTED**  
 THE DRAWINGS AND INFORMATION CONTAINED HEREIN ARE  
 PROPRIETARY AND CONFIDENTIAL AND FOR USE ONLY BY  
 PERSONS WORKING ON PROJECT WITH BARRIER1 SYSTEMS, INC.  
 DO NOT COPY OR REPRODUCE. ALL RIGHTS RESERVED

ITEM / PAGE 4 OF 8  
 NOV. 14, 2019  
 SCALE: N.T.S.

**ELECTRIC CRASH BEAM- MODEL FCB-1200, ASTM M50 CRASH RATED**  
 CRASH RATED AND CERTIFIED TO STOP 15,000 LBS. IMPACT AT 50 MPH

FOR LOCATIONS WITH 1 BARRIER ARM  
 WALL MOUNTED CONTROLLER

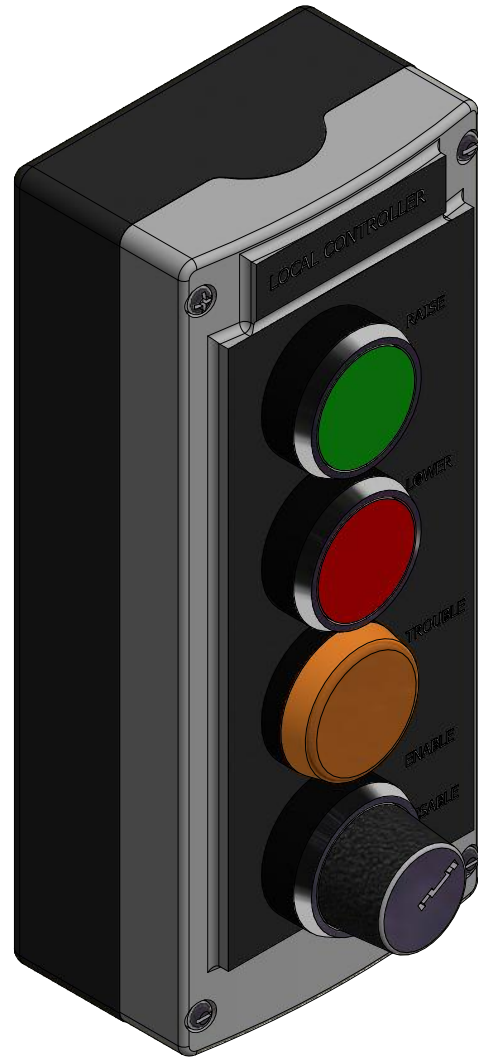

PUSH BUTTON CONTROLS

ORANGE LED

KEYED SWITCH

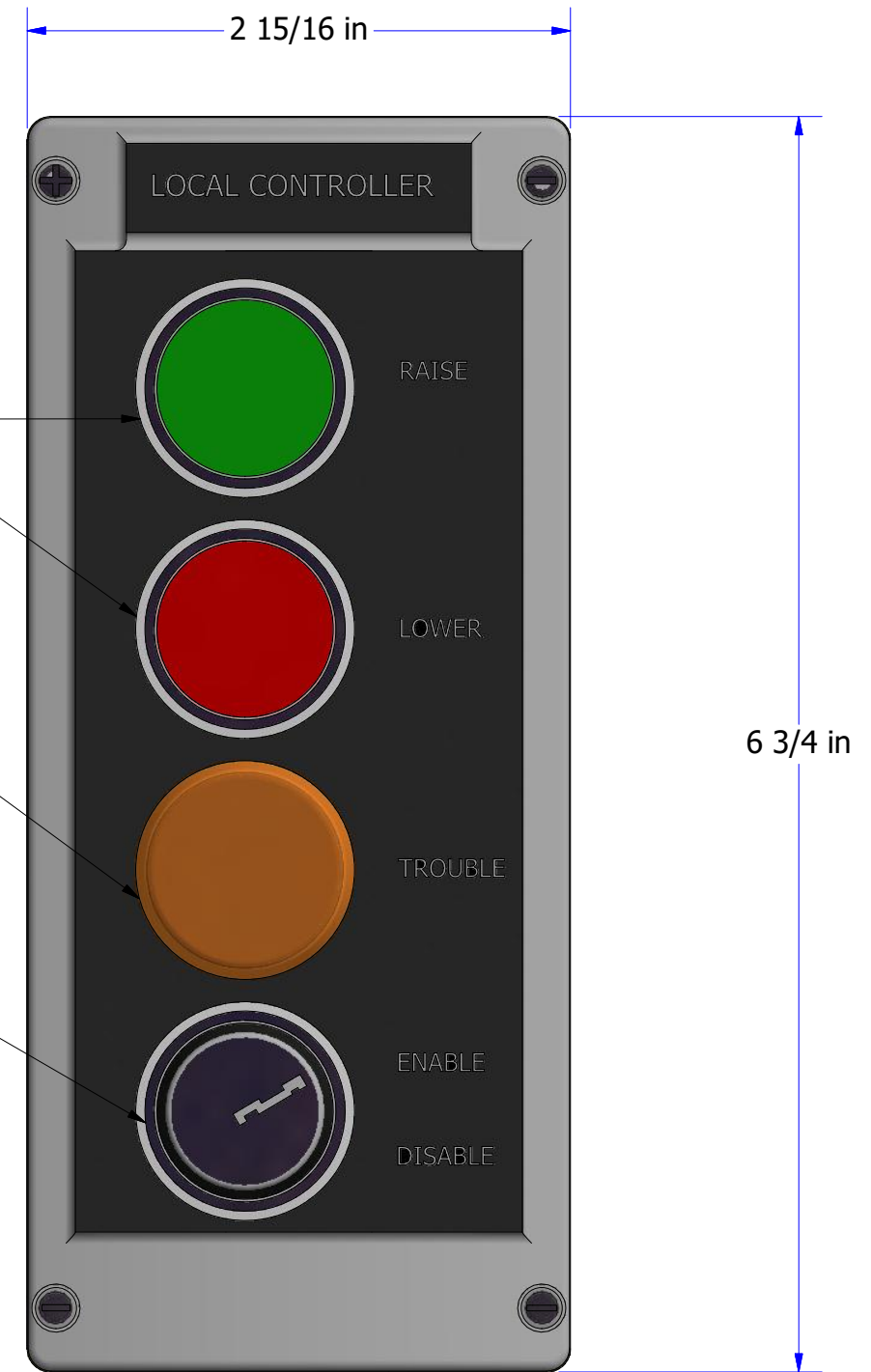

PRELIMINARY DRAWING

**PROPRIETARY AND CONFIDENTIAL**  
**PATENT PROTECTED**

DO NOT COPY OR REPRODUCE. FOR USE WORKING WITH BARRIER1 SYSTEMS ONLY



**BARRIER1 SYSTEMS, INC.**  
 8015 THORNDIKE ROAD  
 GREENSBORO, NC 27409  
 (336) 617-8478 (336) 617-471 FAX  
 mlamore@barrier1.us www.barrier1.us

**PATENT PROTECTED**  
 THE DRAWINGS AND INFORMATION CONTAINED HEREIN ARE  
 PROPRIETARY AND CONFIDENTIAL AND FOR USE ONLY BY  
 PERSONS WORKING ON PROJECT WITH BARRIER1 SYSTEMS, INC.  
 DO NOT COPY OR REPRODUCE. ALL RIGHTS RESERVED

ITEM / PAGE 5 OF 8  
 NOV. 14, 2019

SCALE: N.T.S.

**ELECTRIC CRASH BEAM- MODEL FCB-1200, ASTM M50 CRASH RATED**  
 CRASH RATED AND CERTIFIED TO STOP 15,000 LBS. IMPACT AT 50 MPH

FOR LOCATIONS WITH 2 BARRIER ARMS  
 DESK MOUNTED CONTROLLER

SAMPLE CONTROLLER

11 15/16 in

COLORED INDICATOR LAMPS

KEYED SWITCHES

PUSH BUTTONS

MAIN CONTROLLER

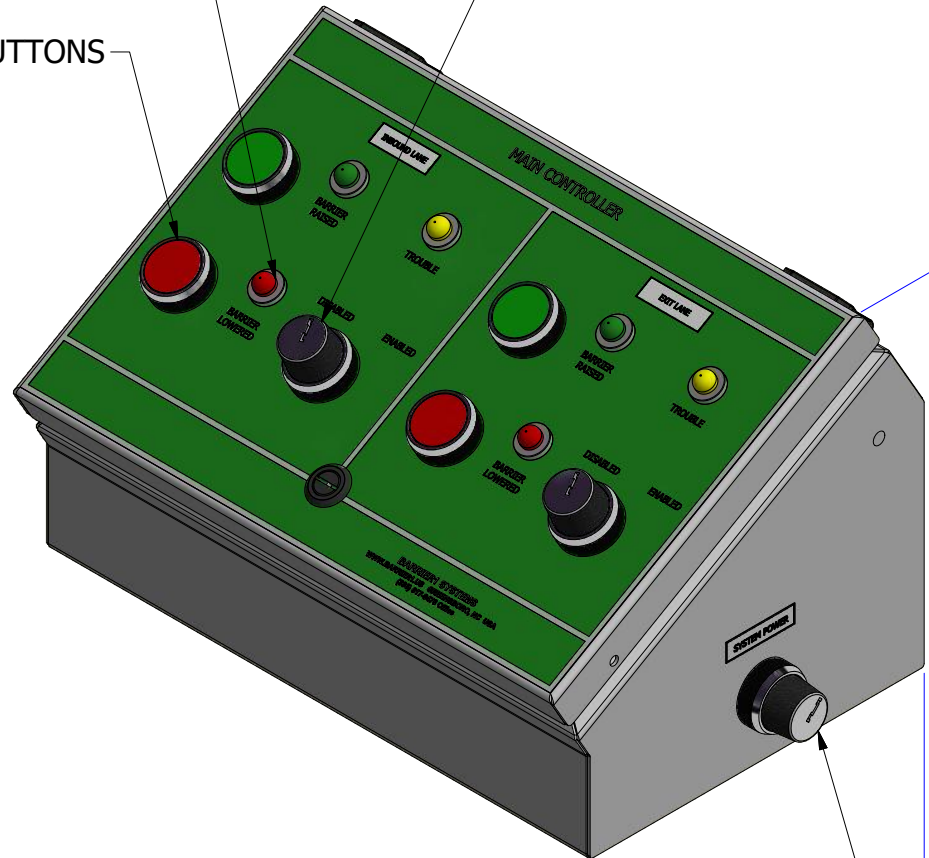

7 5/16 in

7 15/16 in

7 3/8 in

CONTROLLER POWER

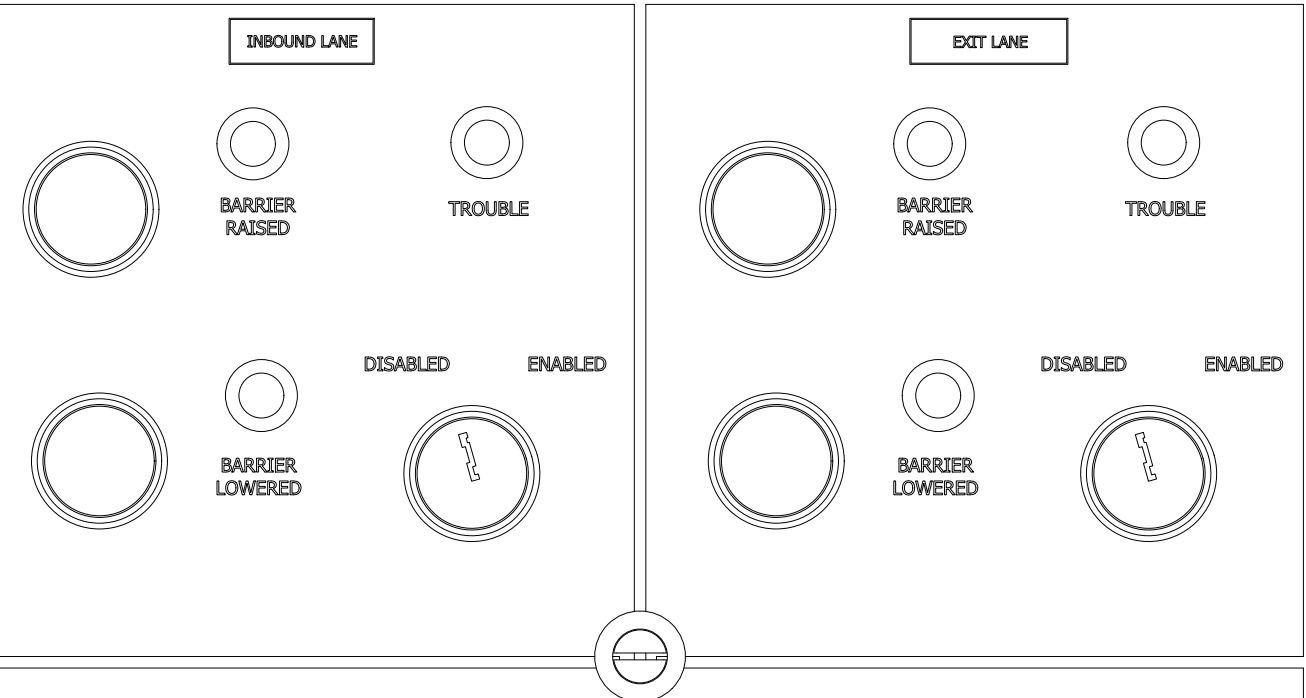

BARRIER1 SYSTEMS  
 WWW.BARRIER1.US GREENSBORO, NC USA  
 (336) 617-8478 Office

PRELIMINARY DRAWING

**PROPRIETARY AND CONFIDENTIAL**  
**PATENT PROTECTED**

DO NOT COPY OR REPRODUCE. FOR USE WORKING WITH BARRIER1 SYSTEMS ONLY



**BARRIER1 SYSTEMS, INC.**  
 8015 THORNDIKE ROAD  
 GREENSBORO, NC 27409  
 (336) 617-8478 (336) 617-471 FAX  
 mlamore@barrier1.us www.barrier1.us

**PATENT PROTECTED**  
 THE DRAWINGS AND INFORMATION CONTAINED HEREIN ARE  
 PROPRIETARY AND CONFIDENTIAL AND FOR USE ONLY BY  
 PERSONS WORKING ON PROJECT WITH BARRIER1 SYSTEMS, INC.  
 DO NOT COPY OR REPRODUCE. ALL RIGHTS RESERVED

ITEM / PAGE 6 OF 8  
 NOV. 14, 2019

SCALE: N.T.S.

**ELECTRIC CRASH BEAM- MODEL FCB-1200, ASTM M50 CRASH RATED**  
 CRASH RATED AND CERTIFIED TO STOP 15,000 LBS. IMPACT AT 50 MPH

FOR LOCATIONS WITH 3 BARRIER ARMS  
 DESK MOUNTED CONTROLLER

SAMPLE CONTROLLER

12 in

MAIN CONTROLLER

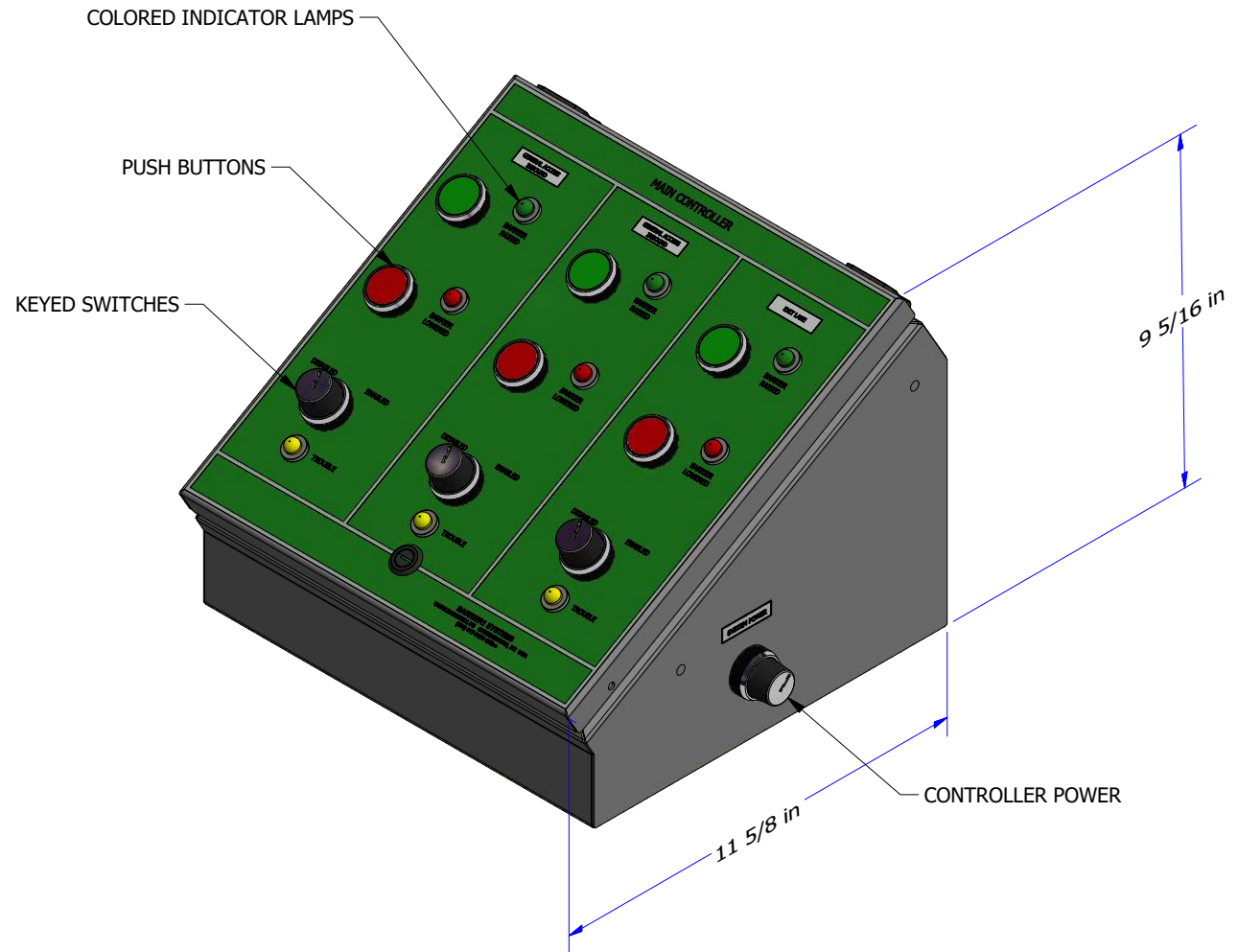

11 15/16 in

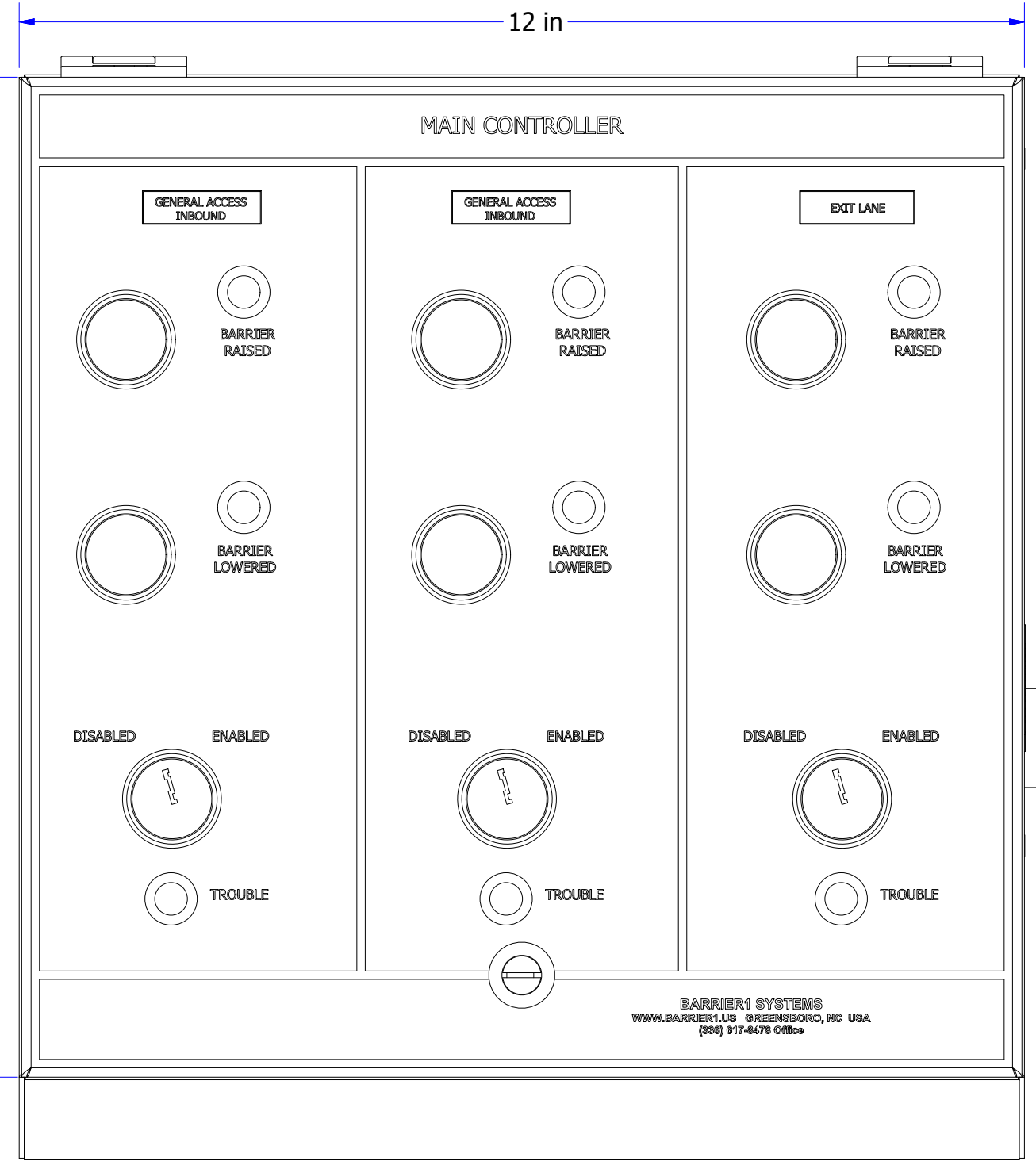

PRELIMINARY DRAWING

**PROPRIETARY AND CONFIDENTIAL**  
**PATENT PROTECTED**  
 DO NOT COPY OR REPRODUCE. FOR USE WORKING WITH BARRIER1 SYSTEMS ONLY



**BARRIER1 SYSTEMS, INC.**  
 8015 THORNDIKE ROAD  
 GREENSBORO, NC 27409  
 (336) 617-8478 (336) 617-471 FAX  
 mlamore@barrier1.us www.barrier1.us

**PATENT PROTECTED**  
 THE DRAWINGS AND INFORMATION CONTAINED HEREIN ARE PROPRIETARY AND CONFIDENTIAL AND FOR USE ONLY BY PERSONS WORKING ON PROJECT WITH BARRIER1 SYSTEMS, INC. DO NOT COPY OR REPRODUCE. ALL RIGHTS RESERVED

ITEM / PAGE 7 OF 8  
 NOV. 14, 2019  
 SCALE: N.T.S.

**ELECTRIC CRASH BEAM- MODEL FCB-1200, ASTM M50 CRASH RATED**  
 CRASH RATED AND CERTIFIED TO STOP 15,000 LBS. IMPACT AT 50 MPH

**PROPRIETARY AND CONFIDENTIAL**  
**PATENT PROTECTED**

DO NOT COPY OR REPRODUCE. FOR USE WORKING WITH BARRIER1 SYSTEMS ONLY

**PRELIMINARY DRAWING**

EMERGENCY FAST OPERATION  
 OVERRIDES AND CLOSES ALL BARRIERS

WIRELESS CONTROLLER OPTION  
 USING SMART PHONE

WIRELESS CONTROLLER OPTION  
 USING REMOTE CONTROLLER

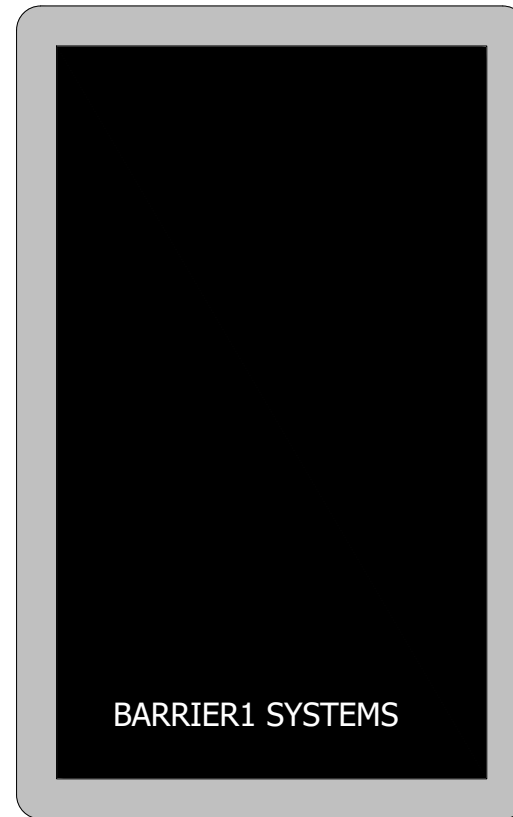
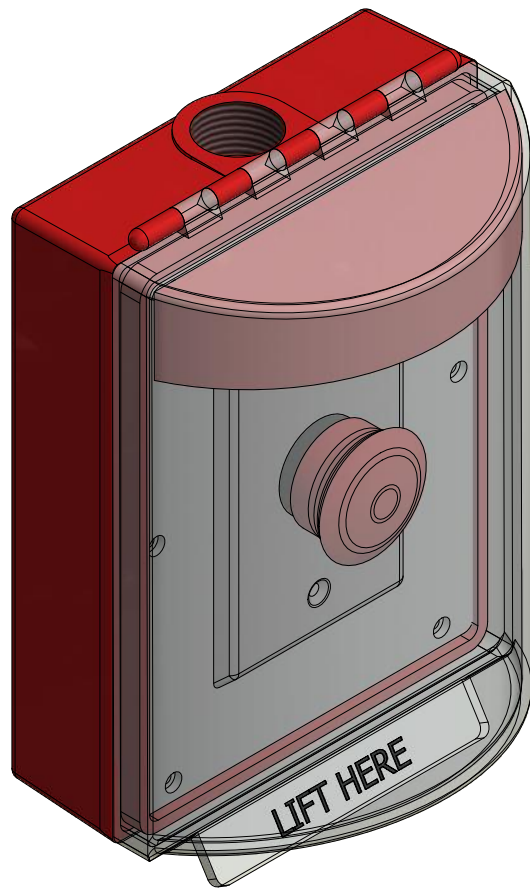

**NOTE:**  
 PRESSING EFO IN EMERGENCY OVERRIDES  
 SAFETY LOOPS; ARM(S) AT GATE  
WILL CLOSE REGARDLESS OF VEHICLE PRESENCE

**ELECTRICAL CRASH BEAM - OPTIONAL ITEMS:**

1. UPS BATTERY BACKUP.
2. TRIGGER LOOPS IN ROADWAY FOR LOGIC TO AUTOMATICALLY OPEN AND CLOSE ARMS.
3. AUDIBLE ALARM WHEN ARM IS BEING LOWERED.
4. SIGNS, ADDITIONAL TRAFFIC SIGNALS, AND WARNING LIGHTS.
5. WIRELESS REMOTE CONTROLLERS.
6. TOUCH SCREEN CONTROLLERS.
7. CONNECTING ADDITIONAL ADJACENT SURFACE SET CONCRETE BLOCKS IN SERIES (REDUCE VEHICLE PENETRATION DISTANCE)



**BARRIER1 SYSTEMS, INC.**  
 8015 THORNDIKE ROAD  
 GREENSBORO, NC 27409  
 (336) 617-8478 (336) 617-471 FAX  
 mlamore@barrier1.us www.barrier1.us

**PATENT PROTECTED**  
 THE DRAWINGS AND INFORMATION CONTAINED HEREIN ARE  
 PROPRIETARY AND CONFIDENTIAL AND FOR USE ONLY BY  
 PERSONS WORKING ON PROJECT WITH BARRIER1 SYSTEMS, INC.  
 DO NOT COPY OR REPRODUCE. ALL RIGHTS RESERVED

ITEM / PAGE 8 OF 8  
 NOV. 14, 2019

SCALE: N.T.S.