

OPERATIONS & MAINTENANCE MANUAL

MODEL 773

Reinforced Crash Arm Vehicle Barrier

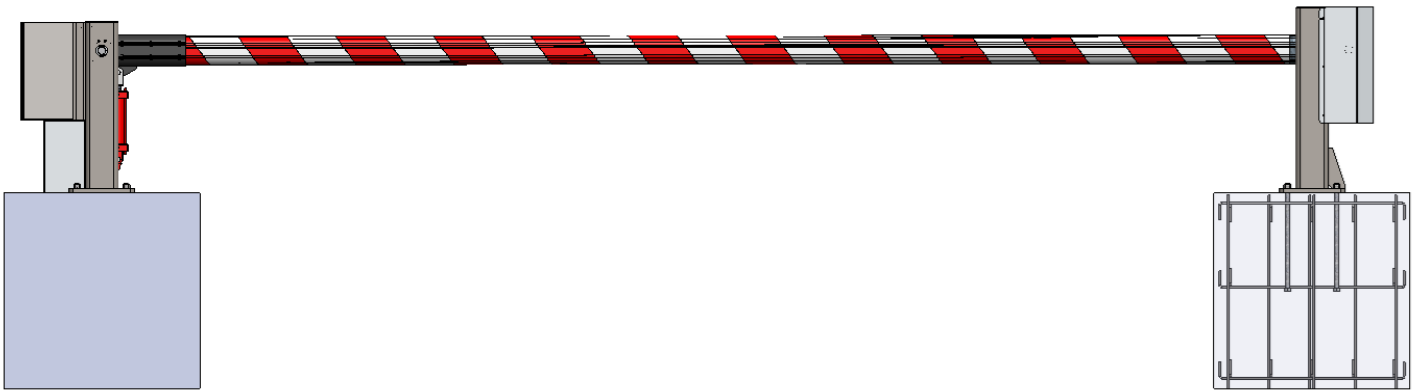

5900 South Lake Forest Drive
Ste. 230

McKinney, TX 75070

Phone: (800) 367-0387 | Fax: (972) 385-9887

Web: www.bb-armr.com | E-mail: info@bb-armr.com

TECH SUPPORT

Phone: 800.367.0387 | E-mail: techsupport@bb-armr.com



MADE IN THE USA



OPERATIONS AND MAINTENANCE MANUAL

MODEL 773 SERIES
REINFORCED CRASH ARM

Contents

System Record	4
1. INTRODUCTION	5
1.1. Preface	5
1.2. Safety Considerations	5
1.3. Safety Symbols	6
1.4. Acronyms	6
1.5. How to Contact Us	8
2. ORIENTATION	8
2.1. Overview	8
2.2. Arm	9
2.3. Stanchion	9
2.4. Drive System	11
2.4.1. Electric	11
2.4.2. Hydraulic	11
2.4.3. Manual	12
2.5. Options	12
3. OPERATION	12
3.1. Introduction	12
3.1.1. Pre-operation Checklist	13
3.2. Initial Startup Process	13
3.3. Initial Operation	13
3.4. Typical Operation	15
3.5. Barrier Operation during a Power Outage	16
4. MAINTENANCE	17
4.1. Introduction	17
4.2. Monthly Inspections	18
4.3. Six-Month Inspections	18
4.4. Annual Inspections	20
5. TROUBLESHOOTING	20
5.1. Model 773 Troubleshooting Guide	20
6. APPENDIX	21
6.1. Drawings	21



OPERATIONS AND MAINTENANCE MANUAL

MODEL 773 SERIES
REINFORCED CRASH ARM

6.1.1. 773E/H Series General Layout	21
6.1.2. 773E/H Series Foundation and Clear Opening Details.....	22
6.1.3. 773M Series General Layout	23
6.1.4. 773M Series Foundation and Clear Opening Details	24
6.1.5. Rebar Cage Details	25
6.2. Specifications	26
Equipment Maintenance Log Form	27
Limited Warranty	28

System Record

To assist in documenting the products in your system, please take a minute to record the following reference information. This information can be located on the blue B&B ARMR model number plate found on the 773 drive unit and should also be recorded in the Installation Manual.

Additional columns are added for your convenience in documenting other components in the system.

	Model 773 Barrier		
Site:			
Job #:			
Date:			
Installer:			
Serial Number:			
Model Number:			
Voltage:			
Phase:			

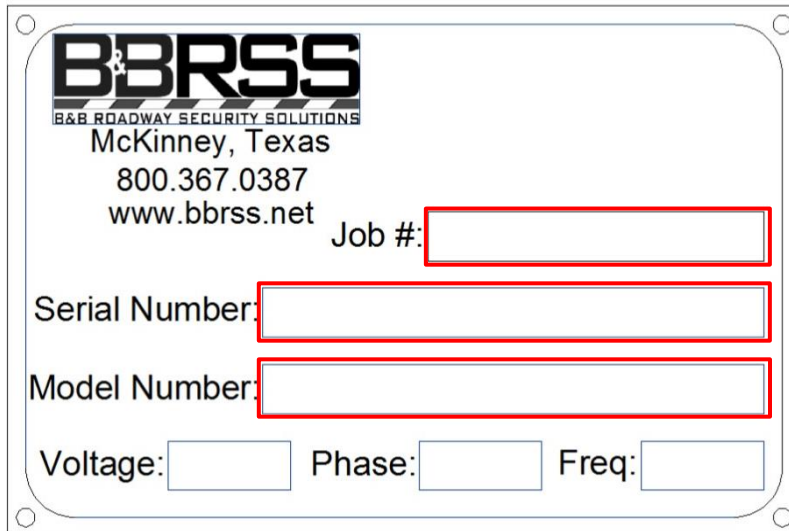

Label 1 - B&B ARMR Blue Product Label with important product data

DO NOT DISCARD THIS MANUAL!

1. INTRODUCTION

1.1. Preface

Welcome!

Congratulations on your purchase of a B&B ARMR vehicle barrier. This manual describes how to operate, maintain and troubleshoot your vehicle barrier. This manual should be fully reviewed in advance of any actual work being done on the equipment.

If you require additional assistance with any aspect of your vehicle barrier's operation, please contact B&B before proceeding.

With years of experience in all aspects of perimeter security and related disciplines, our products are used throughout the world to control access and to protect people, equipment, and facilities. We offer a broad range of vehicle barrier and related perimeter security services:

- Turnkey installations.
- Routine barrier preventative maintenance or emergency repairs (including work on non-B&B products).
- Spare or replacement parts.
- Custom designs or special installations.
- Equipment upgrades or modernization.
- Ancillary security equipment such as security guard enclosures, access control points, security lighting, and many other security related products.
- Technical support via telephone and possible on-site support with advanced scheduling.

The equipment covered by this manual is available with a vast variety of options and accessories. See the Specification Chart at the end of this manual for general unit specifications. Consult the unit labels, approved submittal package, order acknowledgment and other manuals for details on the options, accessories and related specifications provided with the equipment on each project.

The instructions pertaining to the Model 773 Reinforced Crash Arms are intended as a guide and do not supersede local or national codes. Consult local codes before installation.

1.2. Safety Considerations

B&B does not assume responsibility for injury to persons or property during operation or maintenance. As an operator or service technician, you are responsible for correct, safe operation of this equipment. You must follow the specific instructions and safety precautions located in this manual. In addition, you shall:

- Follow the safety standards of the Occupational Safety and Health Administration (OSHA), as well as other applicable federal, state, and local safety regulations and industry standards and procedures.
- For operation outside the United States, operators must also follow applicable international, regional and local safety standards.
- Engage only trained and experienced staff to operate and maintain the equipment.
- Ensure that any modifications or repairs are performed correctly, using the correct tools and equipment, by properly trained technicians.

1.3. Safety Symbols

The following symbols are used in this document to alert the reader to areas of potential hazard:



DANGER indicates an imminently hazardous situation which, if not avoided, will result in death or serious injury.



WARNING indicates a potentially hazardous situation which, if not avoided, could result in death or serious injury.



CAUTION identifies a hazard which could lead to damage to the machine, damage to other equipment and/or environmental pollution.



NOTE is used to highlight additional information which may be helpful to you.



TIP indicates time saving information.



LIGHTNING FLASH with arrowhead symbol, within an equilateral triangle, is intended to alert the user to the presence of “dangerous voltage” within product's enclosure that may be of sufficient magnitude to constitute a risk of electric shock.

1.4. Acronyms

The following is a list of acronyms common to the industry and used throughout this manual.

- **ASTM** – American Society for Testing and Materials: A voluntary leader in the development of consensus standards for product definition, testing and certification. Most perimeter security products are tested by 3rd party testing/engineering agencies, using ASTM standards.
- **BBU** – Battery Backup Unit: An optional enclosure containing components and batteries necessary to run control electronics and/or barrier actuators.
- **CO** – Clear Opening: The opening distance of a barrier that is unimpeded or “clear” of any obstructions. For wedge barriers, this typically refers to the width of the attack plate/assembly size. For arm barriers, this commonly refers to the distance between stanchions that is clear to traffic. Clear opening does not mean overall size or in the case of arm barriers, arm length.

- **DCA** – Drive Clevis Assembly: A group of components (assembly) specific to the 828 Series of products used to interface the actuator with the barrier. This assembly includes bolts, pins, blocks and other components.
- **DOS** – Department of State: An abbreviation commonly used to refer to Department of State crash ratings such as, K4, K8 and K12. Most DOS requirements have been replaced with newer ASTM standards for crash rating.
- **EFO** – Emergency Fast Operation: A term used to describe a situation where a barrier operates at an emergency maximum speed. Not all products are capable of EFO. EFO is typically achieved by using specialty electro-linear actuators or pressure accumulators for hydraulically driven systems. EFO is normally activated by an “Emergency” button on a control panel or through software.
- **EPU** – Electric Power Unit: A control enclosure used to house the various control devices for an electrically actuated barrier. This enclosure is typically mounted remotely, away from the barrier and is connected via underground conduit. Some units may attach the enclosure directly to the barrier, as seen on the 77X series. Typically the control systems operate an electro-linear actuator on the barrier.
- **Ft-lbs.** – Foot Pounds: A unit of work equal to a force of one pound-force through a linear displacement of one foot. This is often used to express torque required to secure fasteners, such as bolts and is commonly represented as Lb-ft (Pound-Feet) to eliminate confusion between torque and work units.
- **HPU** – Hydraulic Pumping Unit: A control enclosure used to house the various control and pumping components for a hydraulically actuated barrier. This enclosure is typically mounted remotely, away from the barrier and is connected to the barrier via underground conduit and hydraulic high pressure hoses. Some enclosures may attach directly to the barrier, as seen on the 77X series. The control systems operate a hydraulic pump and valve system used to drive hydraulic cylinders on the barrier.
- **IM** – Installation Manual: Is an instructional manual that explains the installation requirements and steps for a product series.
- **LED** – Light Emitting Diode: A type of light that consumes low energy and is typically low voltage (below 12V).
- **MLB** – Maintenance Lock Bar: A device used to mechanically lock the linkage arms of an 828 Series Wedge Barrier during maintenance work.
- **O&M** – Operation and Maintenance: Refers to a type of instructional manual used to explain the operation and maintenance requirements of a product series.
- **PLC** – Programmable Logic Controller: A programmable solid state electronic control device that controls machinery by using predetermined program logic.
- **PSF** – Pounds Force per square foot: A unit of measure for pressure over a given area.
- **UL** – Underwriters Laboratory: A 3rd party standards development, testing and certification agency.

1.5. How to Contact Us

If you have any questions or experience any problems with your vehicle barrier, or if we can help you with any other facility security issues, please contact us:

Tech Support:

B&B ARMR

5900 South Lake Forest Drive, Suite 230

McKinney, TX 75070 USA

Telephone: 800.367.0387

Fax: 972.385.9887

E-mail: info@bb-armr.com

E-mail2: techsupport@bb-armr.com

2. ORIENTATION

2.1. Overview

The B&B ARMR Model 773 *Reinforced Crash Arm Vehicle Barrier* is an arm-type barrier hinged at one side such that the arm can be raised and lowered to restrict and control vehicle access. The arm is reinforced with an interior energy absorption material to increase the barrier's vehicle stopping capability.

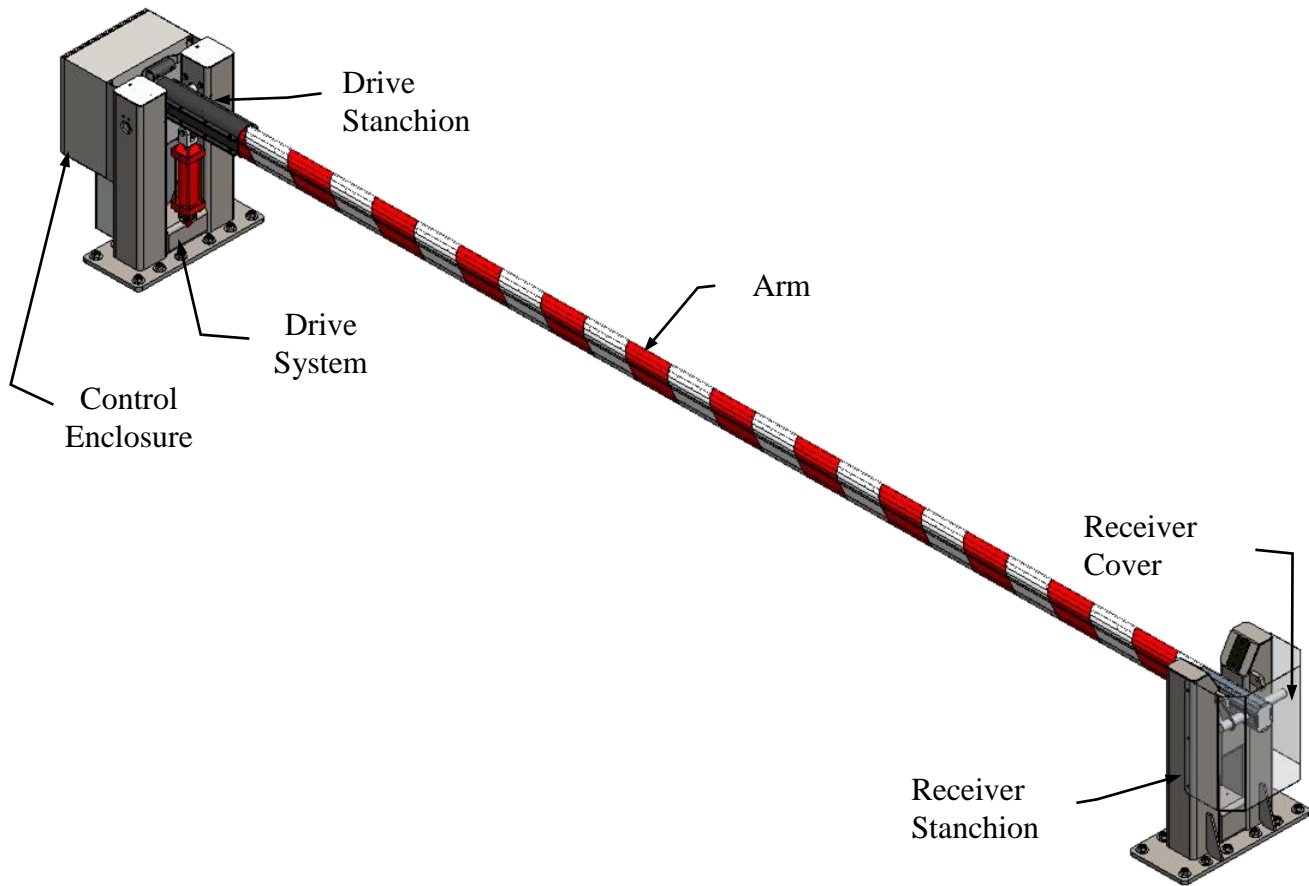

Figure 1- Model 773HD Reinforced Crash Arm Barrier

2.2. Arm

The arm is an aluminum extrusion and is marked with red and white safety tape (alternate colors available). The energy absorption material is contained inside the arm and anchored with retention pins at either end. The impact energy is absorbed by the internal material and transferred to the foundation through the drive and receiver stanchion assemblies.

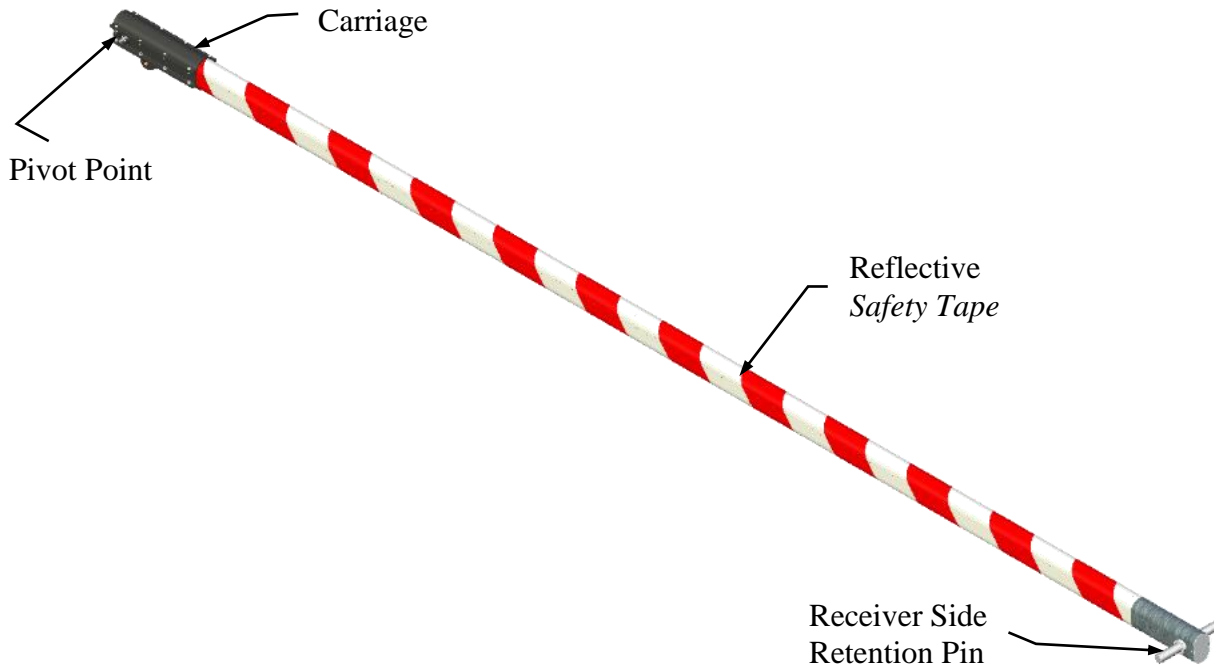

Figure 2 – Arm Assembly

2.3. Stanchion

The drive and receiver stanchions are constructed using heavy gauge steel.

The drive stanchion **Figure 3 - Drive Stanchion (Model 773HD Shown)** operates with internal bearings on a steel hinge pin that allows the arm to open vertically. The receiver stanchion **Figure 4 - Receiver Stanchion** directs and captures the arm when it is lowered. The receiver stanchion has a removable security latching device to prevent unauthorized operation when the barrier is unattended.



Do not attempt to operate the barrier when the latch device is installed.

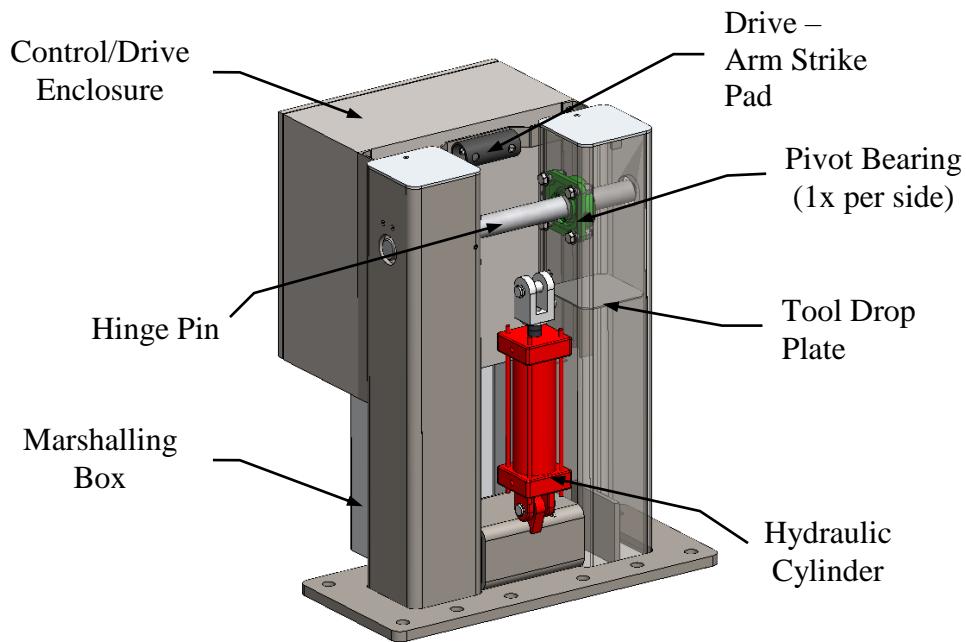

Figure 3 - Drive Stanchion (Model 773HD Shown)

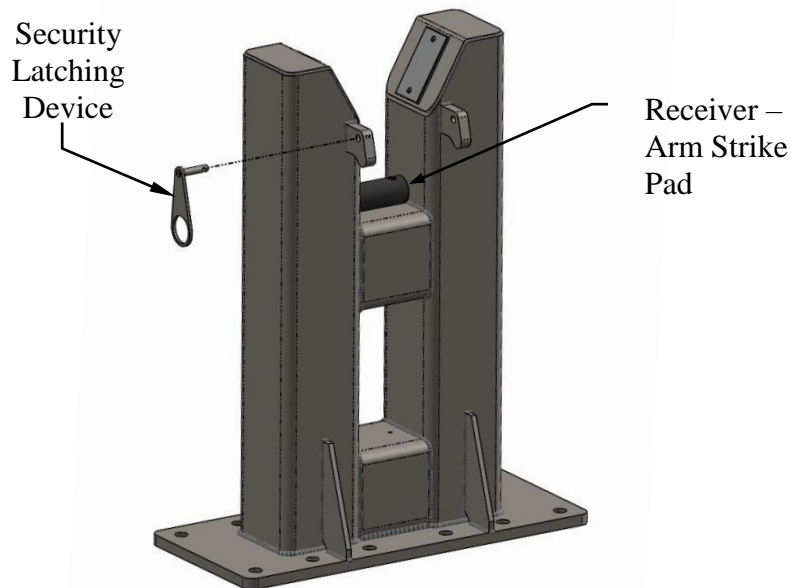

Figure 4 - Receiver Stanchion

The barrier has an exterior-mounted, dampening strike pad. When the barrier operates at the design speed, this damper reduces any whipping action by the arm as it comes to the full, raised position.

Both the drive and receiver stanchion are bolted to an anchor assembly cast into a subterranean concrete pour (see **Figure 5 – Subterranean Foundations**).

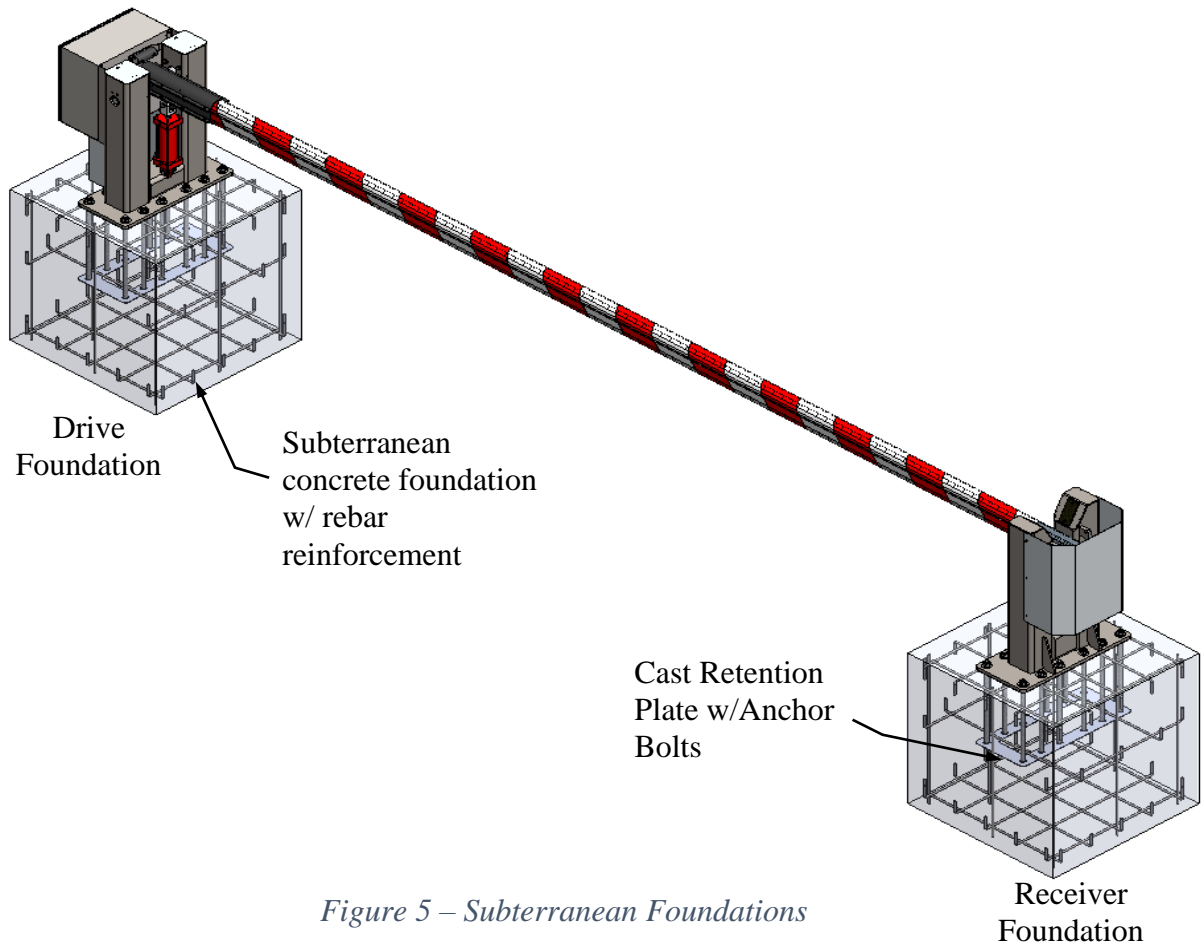

Figure 5 – Subterranean Foundations

2.4. Drive System

The drive system options are:

2.4.1. Electric

The 773ED, or remote mount version 773ER, barrier operates with a self-contained electric drive actuator. A 773ED/ER contains the actuator components, the electrical components and a programmable logic controller pre-programmed with the barrier's operating logic.

The unit includes a manual operation override so the arm can be raised and lowered during power outages.

2.4.2. Hydraulic

The 773HD, or remote mount version 773HR, barrier operates with a self-contained hydraulic pumping (HPU) unit. A 773HD/HR contains the hydraulic pump, control valves and connections and the programmable logic controller pre-programmed with the barrier's operating logic. Miscellaneous electrical components power the HPU and control circuits.

The system includes a manual operation override so the arm can be raised and lowered during power outages.

2.4.3. Manual

The 773MD barrier is manually operated by designated personnel. A standard 773MD contains no electrical components, but may include options or accessories that require electrical connections (e.g., led lights, electromagnetic lock).

Consult the unit labels, approved submittal package or order acknowledgment on the options and accessories related to each project.

2.5. Options

The Model 773 *Reinforced Crash Arm Vehicle Barrier* is available with the following options. Consult your approved submittal package or purchase order to determine whether your unit has any optional equipment.

- Various control panel options (touch screen panels, multiple panels, remote mounting)
- Integrated LED Lights to increase the arm's visibility
- Cold weather package (includes stanchion heaters)
- Electromagnetic Lock
- Battery Back Up System
- Custom Painted Finish

Additional system safety devices may be required with this barrier system:

- In-ground loop detector.
- Pole mounted traffic lights.
- IR beams.
- Safety Edge Strips.

3. OPERATION

3.1. Introduction

The section describes the procedure to operate a generic Model 773 vehicle barrier for first-time and continuous operation. Model 773 is designed for quick and easy installation, operation and for minimal maintenance; however, every site is different and each Model 773 varies due to the choice of options or special design features.

Accordingly, the instructions below may have to be varied slightly for your particular unit.

Please refer to the unit label, approved project submittal package, order acknowledgment, or other manuals for details on the options and accessories provided on your Model 773. If you need help, or are unclear about any of these instructions, please contact B&B prior to operation or maintenance for assistance.

3.1.1. Pre-operation Checklist

Before operating the Model 773 vehicle barrier, go through the following checklist and verify that each of these steps has been completed.

- The master power switch on the control circuit box is turned off.
- The gate arm is attached to the Drive Stanchion with the hinge pin, and the setscrews securing the pin to the bearings are tight.
- The electric actuator (773Ex Series) or hydraulic cylinder (773Hx Series) is securely attached to the Drive Stanchion and the gate arm with clevis pins.
- Verify unit has hydraulic fluid (773Hx Series) to recommended level.
- Verify control unit is plugged in and cable is routed clear of barrier operation.
- Verify area is clear of personnel and other obstructions.
- Verify electrical hookups are completed per electrical wiring diagram matching submittal documents.
- Verify the proximity sensors are installed and set to the appropriate positions.

3.2. Initial Startup Process



On initial startup, it is **MANDATORY** to close off the roadway and clear the Barrier area of nonessential personnel. When the 773(Ex, Hx) Barrier is powered for the first time, all personnel should be located safely away from the roadway, drive and receiver stanchion. Barrier movement might be very erratic during initial startup and could result in injury or death if not located safely away from unit.

For model 773Ex or 773Hx, see the appropriate supplementary Operation and Maintenance (O&M) Manual for electrical connections, operation details, programming options and troubleshooting.

Each time the 773(Ex, Hx) is restarted or maintenance is performed, the roadway and personnel should again be cleared to guard against unexpected movement.

3.3. Initial Operation

Perform the following steps the first time you operate the vehicle barrier and also after any major repairs.

- 3.3.1. Ensure the motor disconnect switch is turned to the OFF position.
- 3.3.2. Turn on the power at the master power switch located on the control circuit box. Have someone remain at the power switch during the initial operation in the event there is a malfunction and the unit must be shut down.



The motor disconnect must be in the OFF position before applying power to the control panel. Energizing the control panel will energize the motor if not disconnected with the supplied disconnect. This may result in damage to the control system and/or bodily injury or death.

- 3.3.3. Using the manual drive for the system, raise the arm. (The procedure for doing this will vary depending on the design of your particular control panel.)
- 3.3.4. Carefully observe the arm and make sure it is operating correctly.
- 3.3.5. The arm needs to begin slowing when the arm reaches an almost open position. This open slowdown is controlled by the open slow down limit switch. Check the indicator LED on the limit switch to ensure it activates when the arm reaches the setpoint.
- 3.3.6. The arm needs to stop once the arm has reached the open position. Check the indicator LEDs on the appropriate open stop limit, light up when the arm is in the fully open position.



On 773Hx Series units, the beam arm motion may not be smooth for the first several operations due to air in the hydraulic lines.

- 3.3.7. If necessary, adjust the open stop limit switch so the switch activates and the arm stops at the correct open position.
- 3.3.8. Using the manual drive for the system, lower the arm. (The procedure for doing this will vary depending on the design of your particular control panel.)
- 3.3.9. Carefully observe the arm and make sure it is operating correctly.
- 3.3.10. The arm needs to begin slowing when the arm reaches an almost closed position. This slowdown is controlled by the close slow down limit switch. Check the indicator LED on the limit switch to ensure it activates when the arm reaches the setpoint.
- 3.3.11. The arm needs to stop once the arm has reached the closed position. Check the indicator LEDs on the appropriate closed stop sensor light up when the arm is in the fully closed position.
- 3.3.12. Turn on the motor power at the motor disconnect located in the control circuit box. Have someone remain at the power switch during the initial operation in case there is a malfunction and the unit must be shut down.
- 3.3.13. Working from the control panel, raise the beam arm. (The procedure for doing this will vary depending on the design of your particular control panel.)
- 3.3.14. Carefully observe the beam and make sure it is operating correctly. The arm will stop when the beam contacts the limit switch or if the control unit times out.
- 3.3.15. If necessary, adjust the limit switch so the switch activates and the beam arm stops at the correct position.



Turn off the motor power when adjusting any limit switches, by using the motor disconnect.

- 3.3.16. Make sure the beam arm stops smoothly in the up position and there is minimal oscillation or whipping action. If necessary, adjust the speed of the arm by using the VFD on 773Ex or 773Hx series. Refer to the EPU/HPU O&M manual for programming instructions.
- 3.3.17. Working from the control panel, lower the beam arm. (The procedure for doing this will vary depending on the design of your particular control panel.)
- 3.3.18. Make sure the beam arm stops smoothly in the receiver post and does not oscillate, contact hard, or make excessive noise.
- 3.3.19. For the nominal 12' beam arm, the beam will rise and fall in 7-10 seconds. Longer arms can take up to 20 seconds.
- 3.3.20. The electric actuator (773Ex Series) and hydraulic pump (773Hx Series) is adjusted at the factory for typical operating conditions. To obtain optimum performance of your barrier, you may have to make a field adjustment to the VFD or the hydraulic pump's flow control valve, (refer to the EPU or HPU O&M manual supplied with the unit).

If at any time the unit acts erratically or a problem arises not detailed in the troubleshooting guide, please contact B&B technical support before proceeding.

- 3.3.21. Verify the complete sequence of operation per the approved project submittal package.
- 3.3.22. Check that all electrical or hydraulic connections (if applicable) are tight and correct, not pinched or leaking.

If any additional support or service is needed for operation or maintenance, please contact B&B.

3.4. Typical Operation

The system receives an OPEN input signal, typically from the barrier up button, a card reader, a loop detector, infrared beam, or a radio remote. The motor then starts and the beam arm begins to lift. When the beam arm reaches the full up position (less than 20 seconds) the open limit switch is activated and the motor turns off.

The beam arm holds this position until a CLOSE input signal is received. The motor then starts and the beam arm begins to fall. When the beam arm reaches the full closed position (less than 20 seconds) the closed limit switch is activated and the motor turns off.

3.5. Barrier Operation during a Power Outage

You can raise and lower the beam arm manually during a power outage. In both the 773Ex and 773Hx Series, the arm will fail in place. Until power is restored you can open or close the arm as follows:

The 773Ex Series:

- 3.5.1. Disconnect the motor power by using the supplied motor disconnect.
- 3.5.2. Turn the power switch to the OFF position (in case power is suddenly restored).
- 3.5.3. Attach a $\frac{3}{4}$ in. socket to a battery powered drill. Use the drill to drive the manual drive sprocket **CLOCKWISE** to **OPEN** the arm or **COUNTERCLOCKWISE** to **CLOSE** the arm. See *Figure 6 - Manual Drive Lug on 773Ex series*. Alternatively, a speed wrench with a $\frac{3}{4}$ in. (18 mm) socket may be used.

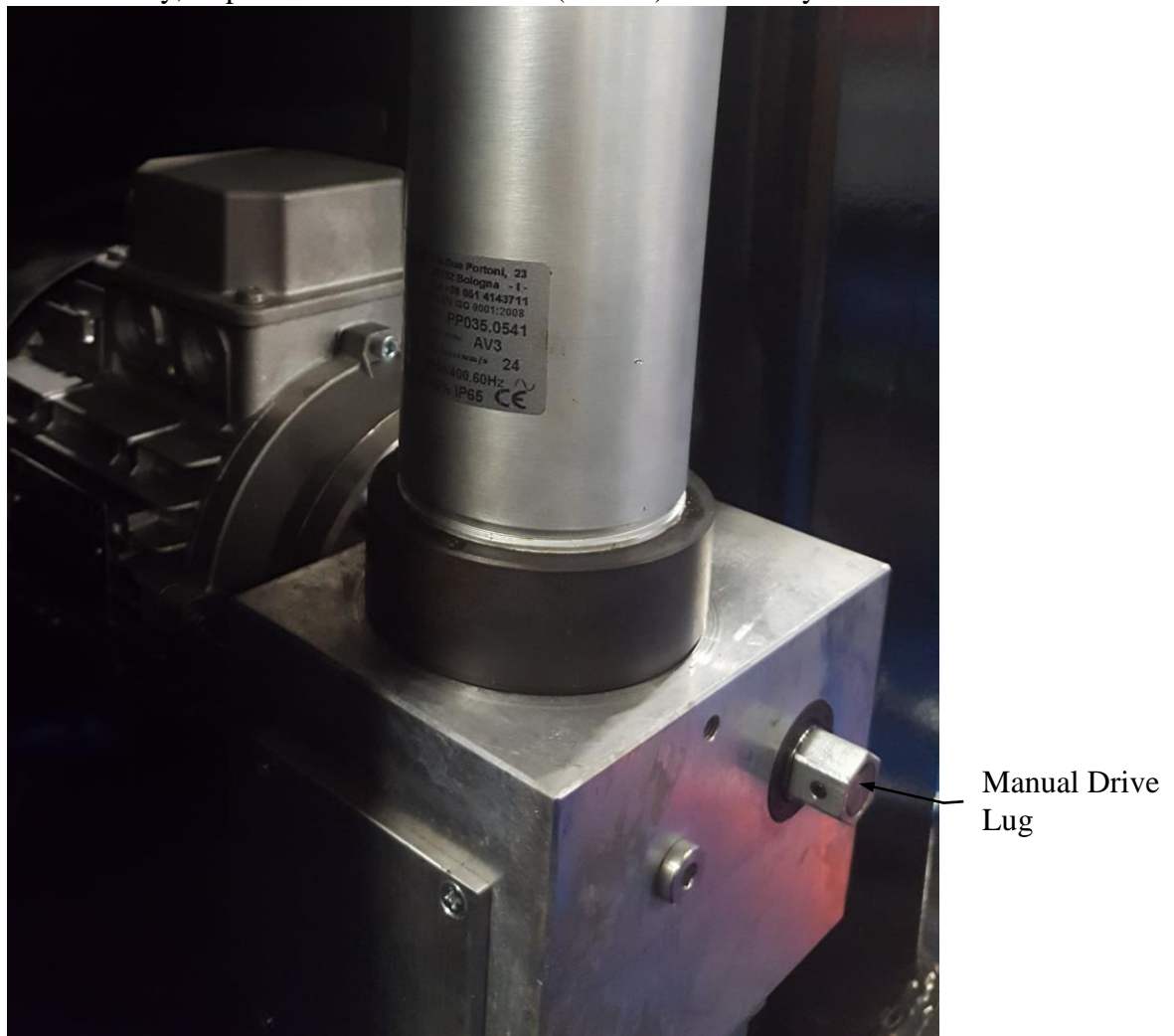

Figure 6 - Manual Drive Lug on 773Ex series



Do not use an impact driver for manually raising or lower the arm. Impact drivers will damage the drive gears in the electro servo. Use a battery powered drill or speed wrench.

773Hx Series:

6130 (for any other HPU, reference that user manual)

- 3.5.4. Turn the power switch to the OFF position (in case power is suddenly restored).
- 3.5.5. Locate the directional control valve on the pump. Insert a flat bladed screwdriver into the RIGHT side solenoid of the valve body and depress the solenoid. See *Figure 7- Directional Control Valve & Solenoid 773Hx Series (6130 HPU)*.

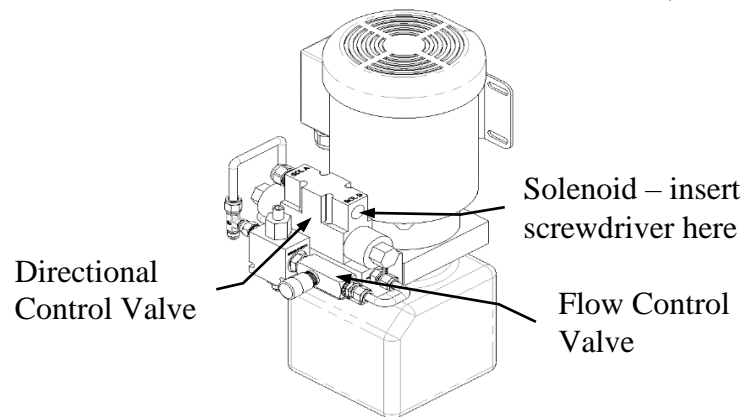

Figure 7- Directional Control Valve & Solenoid 773Hx Series (6130 HPU)

- 3.5.6. If the arm is in the open or partially open state, first locate the flow control valve and close by turning handle clockwise.
- 3.5.7. Locate the solenoid directional valve located on the pump. Reverse the direction of the solenoid by using a flat screwdriver to depress the LEFT side solenoid and put the unit into down position.
- 3.5.8. Slowly open the flow control valve to allow the arm to close. Using the flow control valve allows a controlled arm closure and will prevent damage to the unit caused by a rapid closure.

4. MAINTENANCE

4.1. Introduction

The B&B ARMR Model 773 *Reinforced Crash Arm Vehicle Barrier* is designed to be largely maintenance free. As with any complex electromechanical device however, it must be regularly inspected to ensure it is operating correctly. We recommend a simple monthly visual inspection and a more thorough biannual inspection as described below. Remember, you may contact B&B ARMR for assistance with inspections, maintenance, or repairs.

Component damage is likely if a vehicle strikes the barrier. If an impact occurs, contact B&B ARMR. We will help you assess the damage and make sure there is no hidden

damage that will compromise safety or effectiveness. We will help you determine which components should be replaced and will provide guidance on the repairs.

4.2. Monthly Inspections

We recommend you perform the following visual inspections monthly.

- 4.2.1. Raise and lower the barrier and observe its motion. Verify the speed is within the normal range (7-10 seconds rise time for the standard 12 ft. beam, proportionally longer for longer beams). Verify the beam does not hit with excessive force when lowered. To adjust the speed, see the instructions in the *Operation* section of this manual.
- 4.2.2. Raise and lower the barrier and observe its motion. Verify the damping bumper is working properly and there is minimal whipping or oscillating action as the beam stops in its raised position. If there is excessive whipping, see the instructions in the *Operation* section of this manual for adjustment.
- 4.2.3. Raise and lower the barrier and observe the alignment of the arm. Adjust as necessary.
- 4.2.4. Raise and lower the barrier and observe the limit switch operation. Verify the limit switches are functioning.
- 4.2.5. Raise and lower the barrier and activate the safety devices and verify correct operation.
- 4.2.6. Inspect the condition of the paint. If rust is present, wire brush and sand the area then paint with a primer and the matching color.
- 4.2.7. Inspect the bumper pads on the drive stanchion and the receiver stanchion for damage or excessive wear. Replace the individual bumpers as necessary.
- 4.2.8. Inspect the bearings within the drive stanchion, note abnormal wear, grease and replace as needed.

4.3. Six-Month Inspections

We recommend you perform the following visual inspections every six months.

- 4.3.1. Repeat the visual inspections in steps 4.2.1 through 4.2.8 above.
- 4.3.2. Turn the master power switch on the control circuit box to the **OFF** position.
- 4.3.3. Through the top of the hinge post, access the bearings that hold the stainless steel axle. Grease these bearings through their zerk fittings using a high quality, multi-purpose bearing grease.
- 4.3.4. Setscrews on the bearings hold the stainless steel axle in place. Verify these setscrews are tight.
- 4.3.5. Inspect the clevis pins holding the actuator that raises and lowers the beam. Lubricate the pins with high-quality, multi-purpose bearing grease. If the clevis

pins show signs of wear, replace them. The clevis mountings have wearable bushings pressed into the steel housing. These bushings can also be replaced if they show signs of excessive wear.

4.3.6. For 773Hx Series:

- 4.3.6.1. Inspect the hydraulic unit for signs of oil leaks. Check the hoses for wear or abrasion. Check all fittings for tightness. Inspect the oil level visually on the tank; the level should be at the marked line on the tank. Add oil as necessary. We recommend using environmentally safe oil such as EnviroLogic® 132 or equivalent.



If you replace a hydraulic hose you must make sure the pressure has been relieved before disconnecting the hose fittings. To do this you must turn the power back on and activate the down control on the control panel. Verify that the hydraulic cylinder retracts completely. If it does not fully retract, the hose is still under pressure and must not be serviced. You can manually relieve the pressure by releasing the cartridge valve and verifying that the cylinder moves to its fully retracted position. Turn the power back **OFF** before continuing.

- 4.3.6.2. Open the hydraulic oil tank and inspect the oil for dirt or water. If oil replacement is necessary, see HPU O&M manual.

4.3.7. When the inspection is complete, turn the master power switch on the control circuit box to the ON position.



Safety Note: After any major repairs, repeat the *Preliminary Steps* (see section 3.1) and the *Initial Operation* sequence (see section 3.2) before returning the barrier to service.

4.3.8. For the 773MD unit:

- 4.3.8.1. Check the 1” (25 mm) nuts holding the counterbalance weights. If loose, tighten to 50 ft. lbs (68 Nm). See **Figure 8 - 773MD Counterbalance Assembly** (*weights not shown for clarity*).

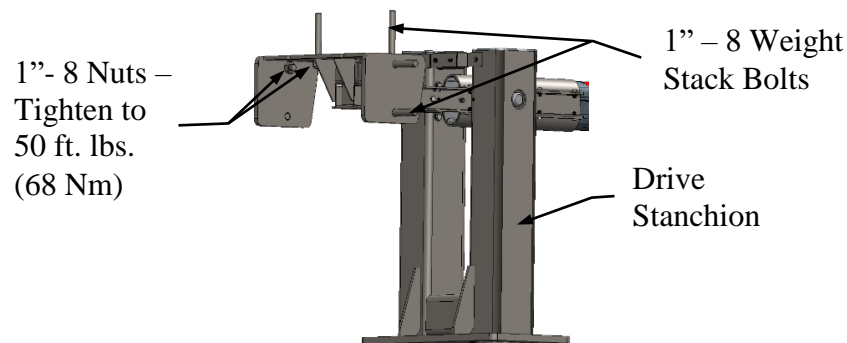

Figure 8 - 773MD Counterbalance Assembly (weights not shown for clarity)

4.4. Annual Inspections

We recommend you perform the following inspections annually.

4.4.1. Repeat the visual inspections in steps 4.2.1 through 4.2.8 above.

4.4.2. For 773Hx Series:

4.4.2.1. Replace the hydraulic oil in the HPU. See HPU O&M manual for instruction.

5. TROUBLESHOOTING

5.1. Model 773 Troubleshooting Guide

The tables below provide guidance on identifying and correcting any problems with your Model 773 Series vehicle barrier. For model 773Ex or 773Hx, please refer to respective manual for more detailed troubleshooting guides referring to the electric actuator or hydraulic pumping unit.

If you encounter problems that you cannot fix, contact B&B ARMR and we will work with you to correct them.

MODEL 773	
Symptom	Actions
Barrier does not raise up when commanded	<ol style="list-style-type: none"> 1. Verify power is supplied to the unit and the circuit breaker is set. 2. Verify the arm is unlocked from the receiver stanchion. 3. Check electrical connections are correct and tight. 4. Check for binding between arm and stanchions. Check connection of linkage between arm and drive unit. 5. Cycle circuit breaker or check fuse(s). 6. If using the onboard controls confirm the correct sequence is followed. 7. Verify safety devices are not missing or have activated.
Barrier does not close when commanded	<ol style="list-style-type: none"> 1. Verify power is supplied to the unit. 2. Verify safety devices have not activated. 3. Cycle circuit breaker or check fuse(s). 4. Check electrical connections are correct and tight. 5. If using the onboard controls confirm the correct sequence is followed. (see EPU/HPU Installation or O&M manual).
Barrier makes noise during operation	<ol style="list-style-type: none"> 1. Check linkage between arm and drive unit. Be sure it is secure and properly lubricated. 2. Check hinge area for debris and proper lubrication. 3. Check drive unit clevis pins for lubrication. 4. Check bearing grease.
Barrier moves too slowly	<ol style="list-style-type: none"> 1. Check for mechanical binds. 2. Check flow control valve (773Hx). 3. In extreme cold temperatures, a different hydraulic fluid may be required to keep viscosity constant (773Hx). 4. If using onboard controls, confirm the correct sequence is followed.

Table 1 – 773(Ex, Hx, MD) Troubleshooting

6. APPENDIX

6.1. Drawings

6.1.1. 773E/H Series General Layout

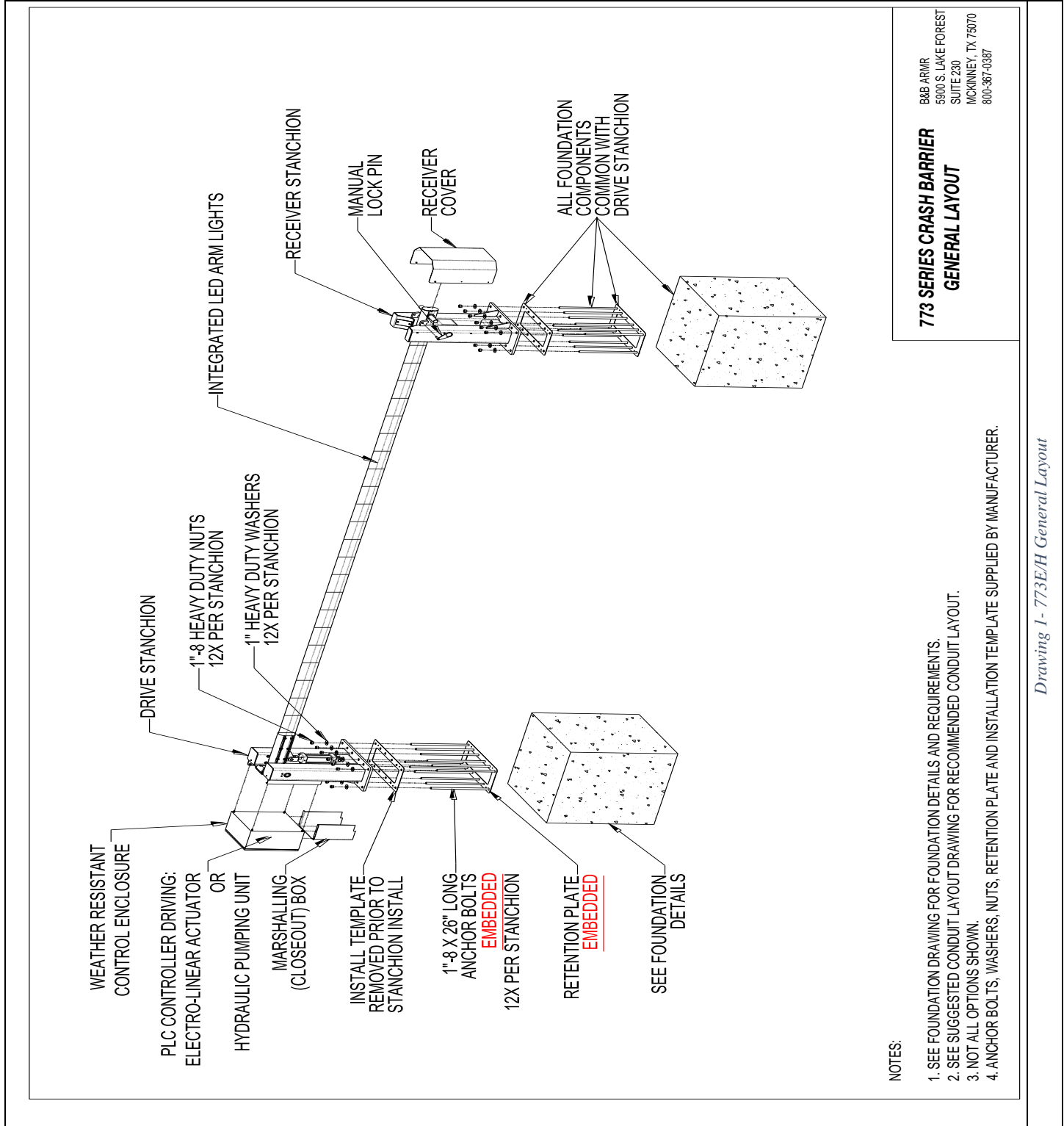

Drawing 1 - 773E/H General Layout

6.1.2. 773E/H Series Foundation and Clear Opening Details

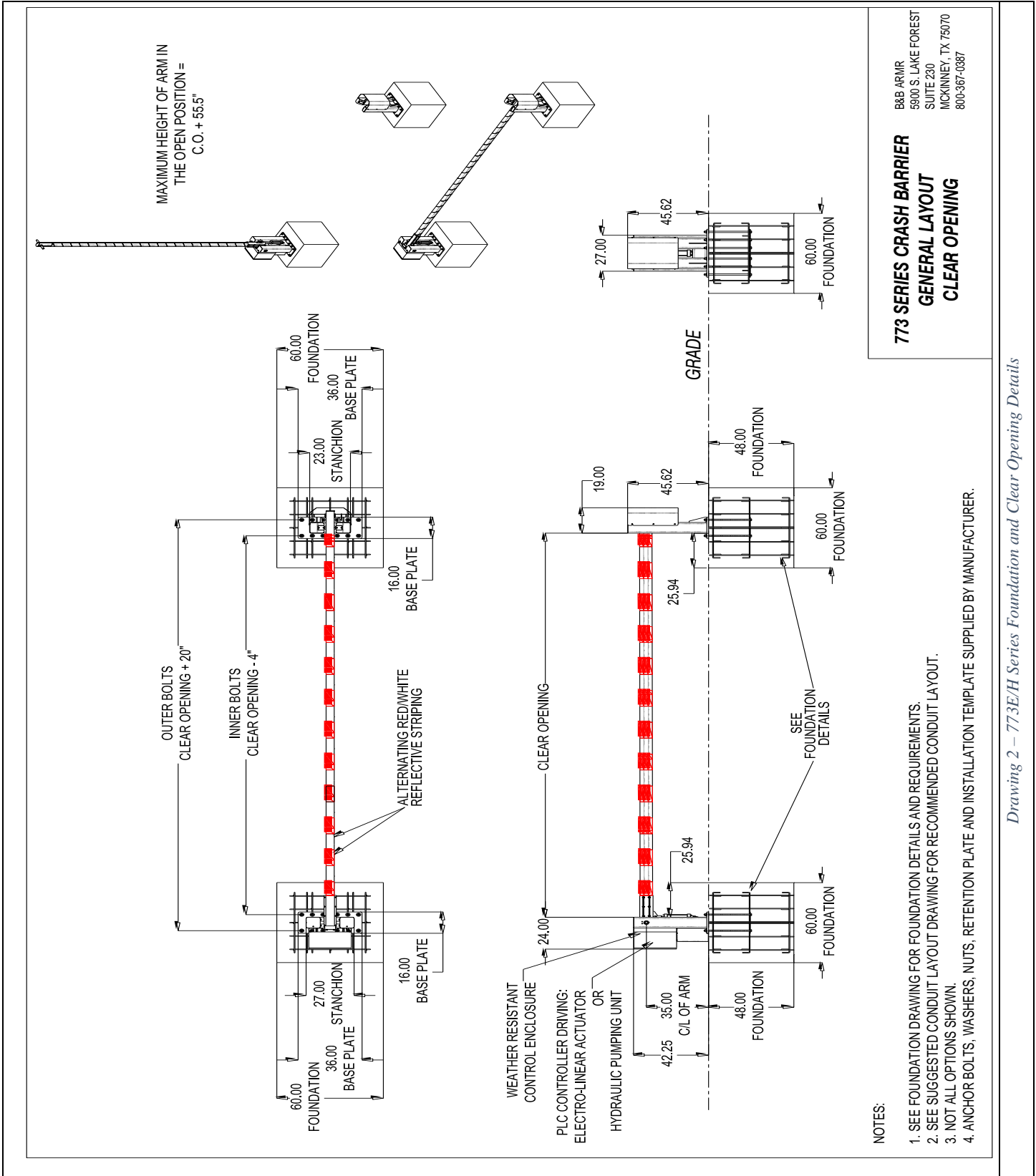

B&B ARMOR
5900 S. LAKE FOREST
SUITE 230
MCKINNEY, TX 75070
800-367-0887

**773 SERIES CRASH BARRIER
GENERAL LAYOUT
CLEAR OPENING**

- NOTES:
1. SEE FOUNDATION DRAWING FOR FOUNDATION DETAILS AND REQUIREMENTS.
 2. SEE SUGGESTED CONDUIT LAYOUT DRAWING FOR RECOMMENDED CONDUIT LAYOUT.
 3. NOT ALL OPTIONS SHOWN.
 4. ANCHOR BOLTS, WASHERS, NUTS, RETENTION PLATE AND INSTALLATION TEMPLATE SUPPLIED BY MANUFACTURER.

Drawing 2 - 773E/H Series Foundation and Clear Opening Details

6.1.3. 773M Series General Layout

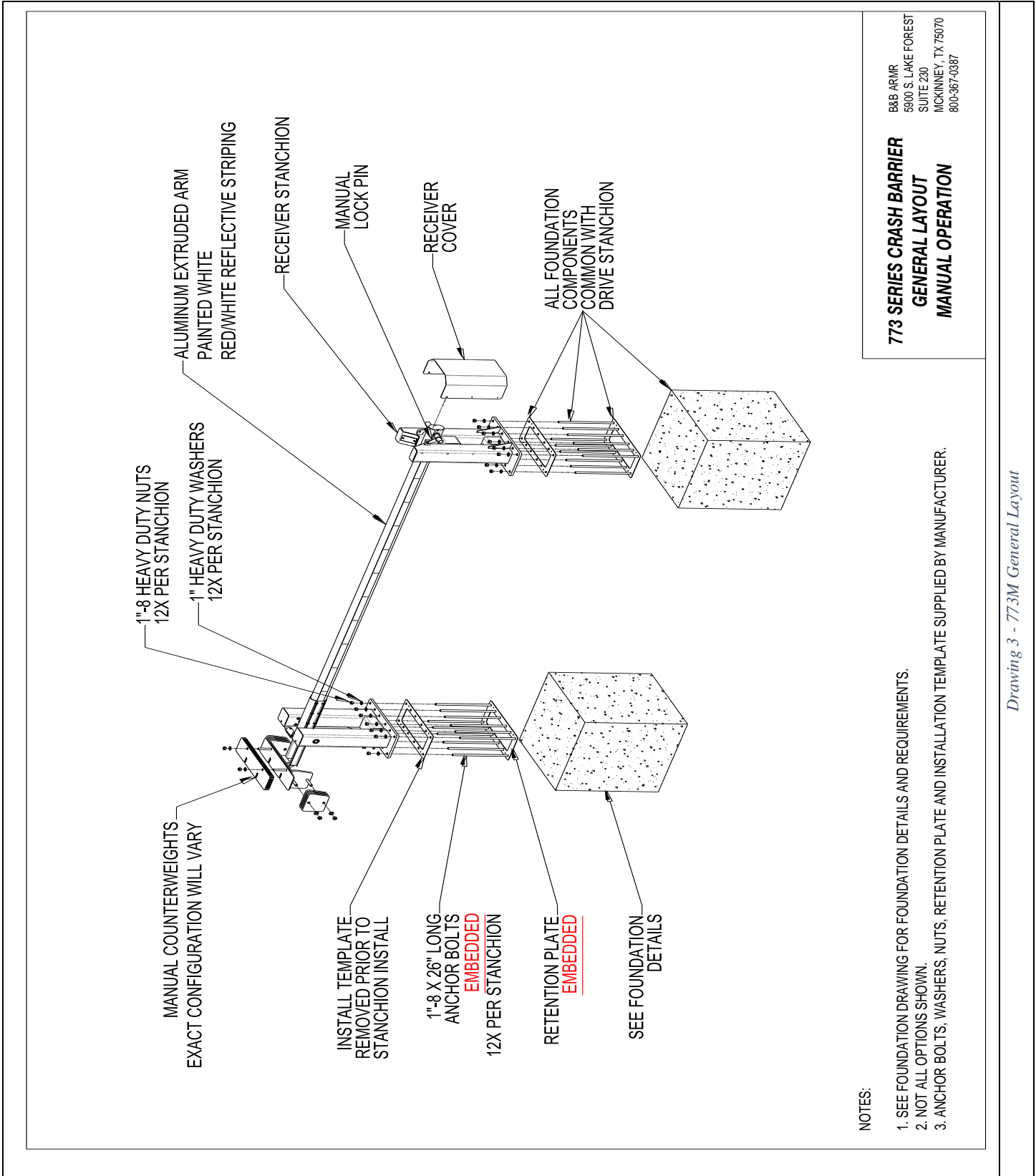

Drawing 3 - 773M General Layout

6.1.4. 773M Series Foundation and Clear Opening Details

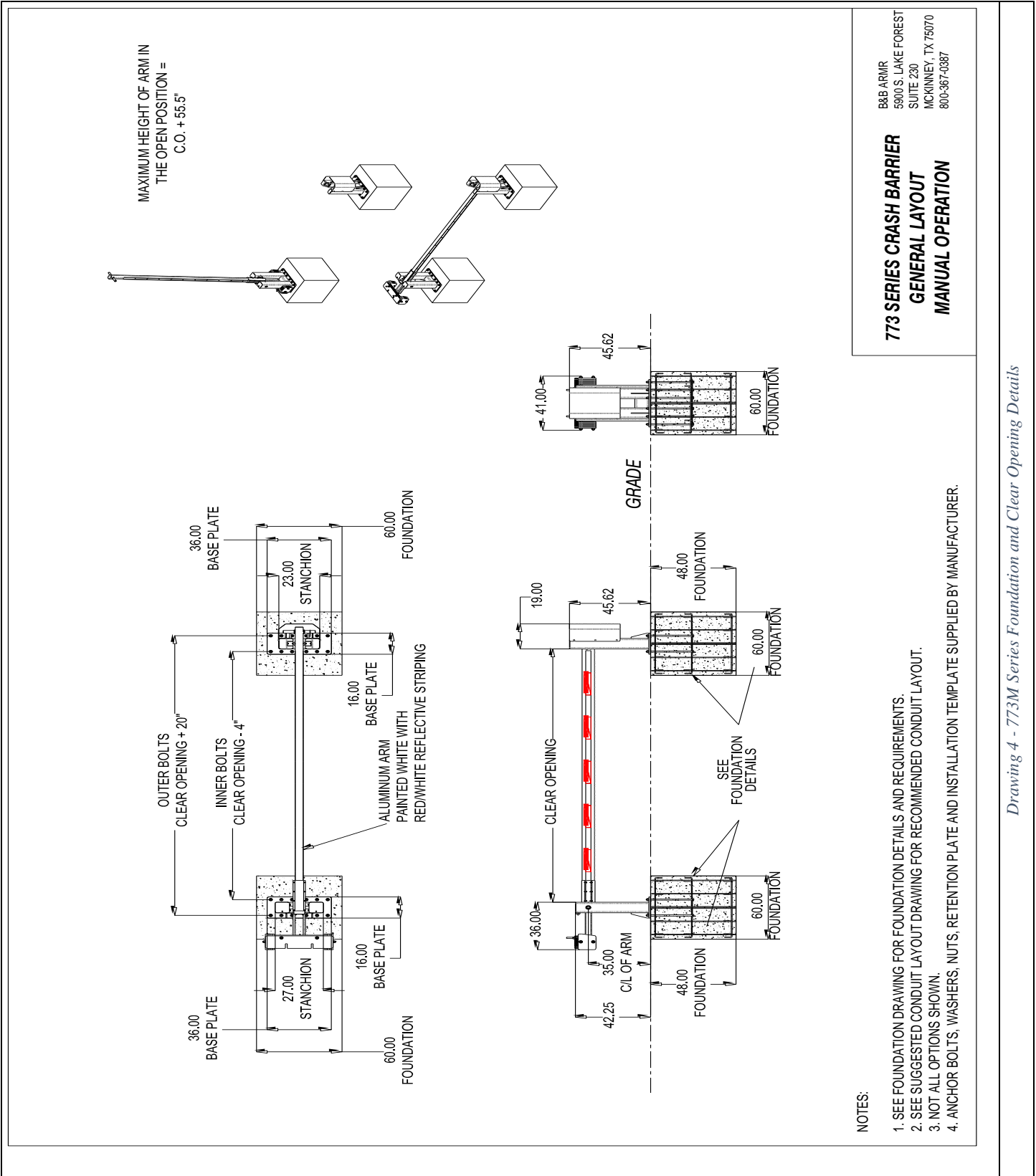

Drawing 4 - 773M Series Foundation and Clear Opening Details

6.1.5. Rebar Cage Details

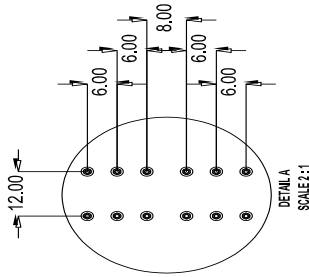
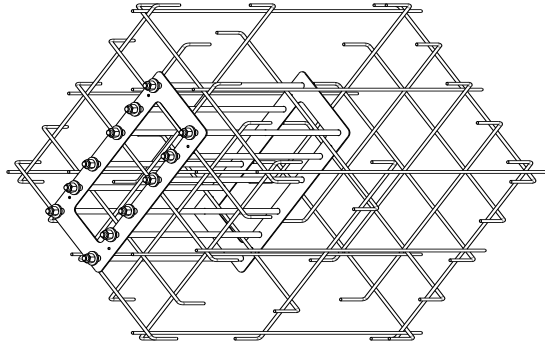

ALL BOLTS
MUST PROTRUDE
2.50" ABOVE
FOUNDATION

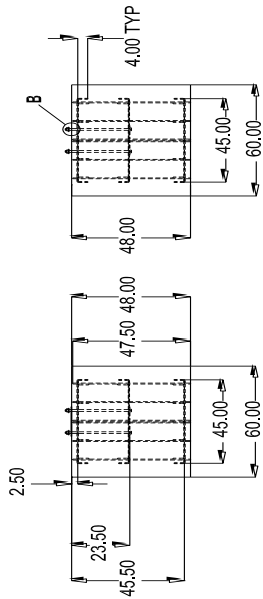
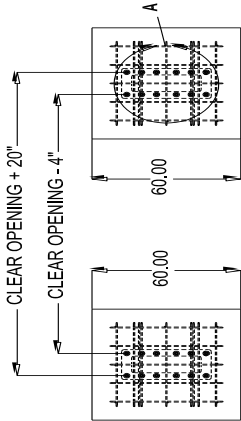
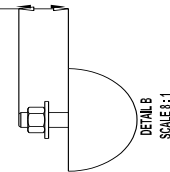

- NOTES:**
1. THE FOUNDATION DIMENSIONS SHOWN ARE CONSIDERED MINIMUM.
 2. THE CONCRETE SHALL DEVELOP A MINIMUM COMPRESSIVE STRENGTH OF 4000 PSI IN 28 DAYS. THE CEMENT SHALL BE AS PER ASTM C150. THE MAXIMUM AGGREGATE SIZE SHALL BE 1 INCH (25.4mm)
 3. THE FOUNDATION SHALL BE POURED ON UNDISTURBED SOIL UTILIZING THE EARTH AS THE FORM FOR THE BOTTOM AND SIDES. FOUNDATION SIZE IS BASED ON MINIMUM ALLOWABLE SOIL BEARING CAPACITY OF 1600 PSF.
 4. ALL REBAR SHALL BE #4 (1/2") MINIMUM, GRADE 60 OR BETTER.
 5. EXTENSIONS BELOW LOWER GRID ARE INTENDED TO ALLOW REBAR CAGE TO BE INSTALLED ON A 48" DEEP EXCAVATION.
 6. UPPER FOUNDATION TEMPLATE TO HAVE A RELEASE AGENT APPLIED TO THE UNDERSIDE PRIOR TO INSTALLATION. TEMPLATE TO BE REMOVED PRIOR TO STANCHION INSTALLATION.

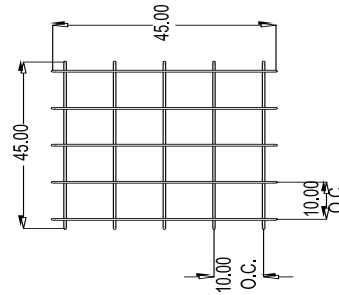

LOWER GRID

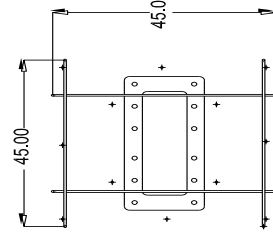

**MIDDLE GRID
USED TO POSITION
AND SECURE EMBEDDED
RETENTION PLATE**

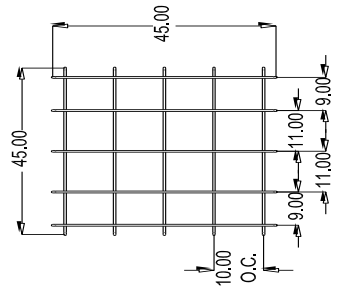

**UPPER GRID
ADJUST POSITION
TO AVOID INTERFERENCE
WITH ANCHOR BOLTS**

B&B ARMOR
5900 S. LAKE FOREST
SUITE 230
MCKINNEY, TX 75070
800-367-0387

**773 SERIES CRASH BARRIER
FOUNDATION REQUIREMENTS**

Drawing 5 - Rebar Cage Details

B&B ARMOR reserves the right to change any information concerning product or specification without notice or obligation.

6.2. Specifications

GENERAL		
TYPE:		Cable Reinforced Vehicle Arresting Barrier
CRASH RATING:		ASTM F2656-15, M30-P1 15,000 lbs. @ 30 mph (6,803 kg @ 48 km/h)
DRIVE SYSTEM:		Electromechanical, Hydraulic or Manual
INSTALLATION		
EXCAVATION:		Minimum 5 ft. x 5 ft. x 4 ft. (1.5 x 1.5 x 1.2 m) excavation per stanchion
SOIL COMPACTION:		1,600 PSF (76.6 kN/m ²) Minimum
CONCRETE:		<ul style="list-style-type: none"> • Concrete must develop a minimum compressive strength of 4000 PSI (27.6 MN/m²) • Concrete must conform to American Concrete Institute (ACI) standards. • Cement shall be per ASTM C150. • Maximum aggregate size is 1 in. (25 mm) • Approximate 3.7 cubic yards (2.8 cubic meters) per stanchion
REBAR:		<ul style="list-style-type: none"> • Rebar shall be #4 deformed billet steel per ASTM A615, Grade 60. • Cages shall be tied together using #4 ties.
DESIGN		
CLEAR VEHICLE OPENING:		Ranges from 12 to 30 ft. (144 – 360 in. / 3.7 – 9.1 m)
CYCLE TIME:	ELECTRIC	STD. Operation 7-15 sec; Field Configurable
	HYDRAULIC	STD. Operation 7-15 sec; Field Configurable
DUTY CYCLE:		Continuous
OPERATING :	TEMPS	-20 – 140° F (-29 - 60° C)
	ANGLE	90° ± 5°
MATERIALS:	STANCHION	Hot dip galvanized Steel
	ARM	6061 aluminum extrusion
ELECTRICAL REQUIREMENTS:	773Ex	• 115-240 VAC 1Ø; 208-480VAC 3Ø
	773Hx	• 115-240 VAC 1Ø; 208-480VAC 3Ø
	773MD	• N/A
DIMENSIONS:		Project Specific – reference Submittal package
OIL:	773Hx	• EnviroLogic® 132 or equivalent
FINISH:		Project specific colored Macropoxy® 646, finished with Acrolon™ 218 acrylic polyurethane



OPERATIONS AND MAINTENANCE MANUAL

MODEL 773 SERIES
REINFORCED CRASH ARM

Equipment Maintenance Log Form



Product Type: _____

B&B ARMR
800-367-0387

Location: _____

techsupport@bb-armr.com

	Date	Performed By	Checklist Complete	Anomalies	Notes
Jan			Yes No		
Feb			Yes No		
Mar			Yes No		
Apr			Yes No		
May			Yes No		
Jun			Yes No		
Jul			Yes No		
Aug			Yes No		
Sep			Yes No		
Oct			Yes No		
Nov			Yes No		
Year			Yes No		

	Date	Performed By	Checklist Complete	Anomalies	Notes
Jan			Yes No		
Feb			Yes No		
Mar			Yes No		
Apr			Yes No		
May			Yes No		
Jun			Yes No		
Jul			Yes No		
Aug			Yes No		
Sep			Yes No		
Oct			Yes No		
Nov			Yes No		
Year			Yes No		



OPERATIONS AND MAINTENANCE MANUAL

MODEL 773 SERIES
REINFORCED CRASH ARM

Limited Warranty

B&B ARMR warranties for a period of one (1) year FOB manufacturing facility, unless otherwise specified by B&B ARMR in writing, from defects due to faulty material or workmanship. Damage due to handling during shipment and installation are not covered under warranty. B&B ARMR assumes no responsibility for service at customer site. B&B ARMR is in no event responsible for any labor costs under the warranty. Subject to the above limitation, all service, parts, and replacements necessary to maintain the equipment as warranted shall be furnished by others. B&B ARMR shall not have any liability under these specifications, other than for repair or replacement as described above for faulty product material or workmanship. Equipment malfunction or equipment failure of any kind, caused for any reason, including, but not limited to unauthorized repairs, improper installation, installation not performed by B&B ARMR authorized personnel, incoming supply power is outside the tolerance for the product, failure to perform manufacturer's suggested preventative maintenance, modifications, misuse, accident, catastrophe, neglect, natural disaster, are not under warranty.

The exclusive remedy for breach of any warranty by B&B ARMR shall be the repair or replacement at B&B ARMR's option, of any defects in the equipment. **IN NO EVENT SHALL B&B ARMR BE LIABLE FOR CONSEQUENTIAL OR SPECIAL DAMAGES OR ANY KIND OF PERSONAL DAMAGES.** Except as provided herein, B&B ARMR makes no warranties or representations to consumer or to anyone else and consumer hereby waives all liability against B&B ARMR as well as any other person for the design, manufacture, sale, installation, and/or servicing of the Products.

THE FOREGOING WARRANTIES ARE IN LIEU OF ALL OTHER WARRANTIES EXPRESS OR IMPLIED, INCLUDING THE IMPLIED WARRANTY OF MERCHANTABILITY AND FITNESS FOR A PARTICULAR PURPOSE. NO OTHER WARRANTIES EXIST.

ANY MODIFICATION OR ALTERATION BY ANYONE OTHER THAN B&B ARMR WILL RENDER THE WARRANTY HEREIN AS NULL AND VOID.