

NOTES:

- ① ARMORTEX[®] BULLET RESISTANT ARMOR
- ② ARMORTEX[®] BULLET RESISTANT GLAZING
- ③ EXTRUDED ALUMINUM FRAME (CLEAR ANODIZED)
- ④ GLAZING TAPE
- ⑤ STAINLESS STEEL CAPS
- ⑥ STAINLESS STEEL DEAL TRAY
- ⑦ HIGH PRESSURE LAMINATED BLACK PLASTIC SHELF (STAINLESS STEEL OPTIONAL)
- ⑧ NEOPRENE SETTING BLOCK
- ⑨ SPEAKER
- ⑩ ANCHORS AS REQUIRED (NOT SHOWN)

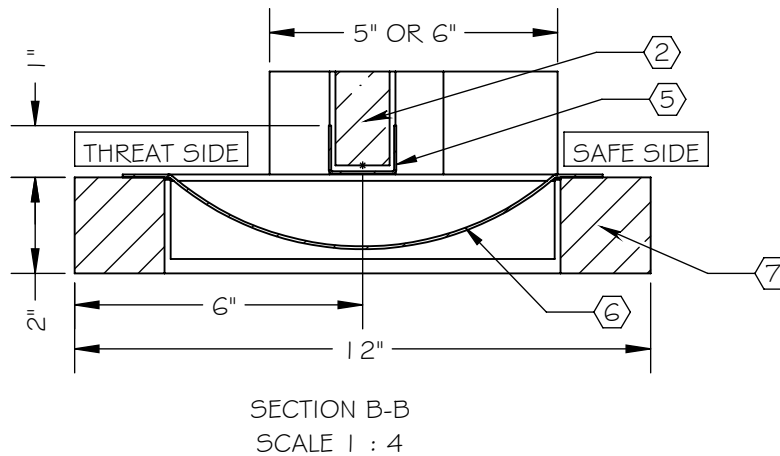
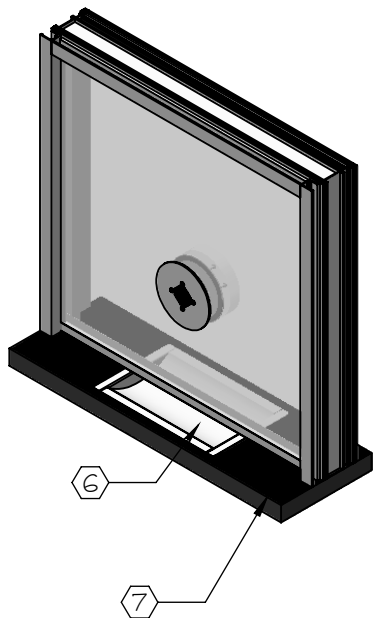
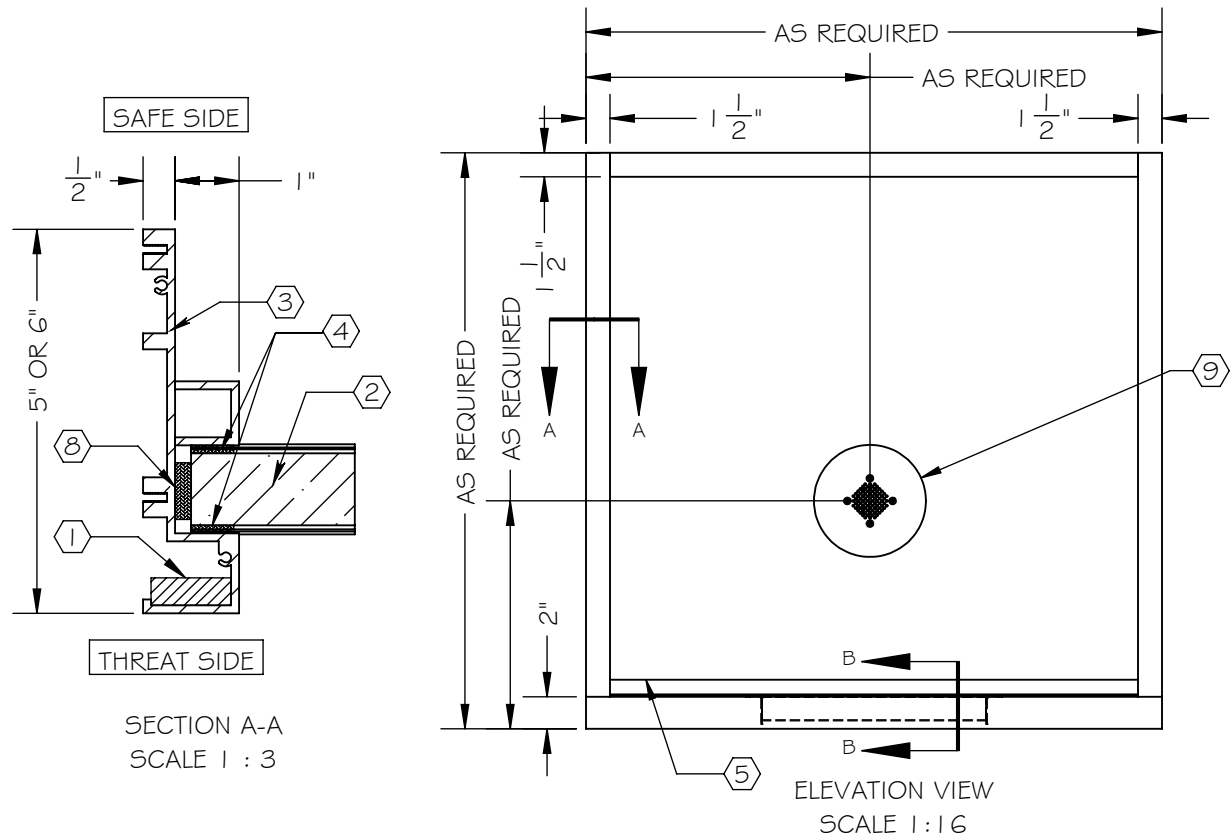

SCALE: AS NOTED	TITLE: ALUMINUM TRANSACTION WINDOW W/SPEAKER	UNLESS OTHERWISE SPECIFIED: DIMENSIONS ARE IN INCHES TOLERANCES: FRACTIONAL: ±1/16" ANGULAR: ±1° TWO PLACE DECIMAL ±.01 THREE PLACE DECIMAL ±.005
DATE: 06-22-2015	MODEL: WI-TW-AL-SP	ARMORTEX[®] BULLET • BLAST • FORCED ENTRY - PROTECTION PRODUCTS 5926 CORRIDOR PKWY SCHERTZ, TX 78154 TEL: 210-661-8306 800-880-8306 FAX: 210-661-8308 www.armortex.com
DRAWN BY: M. FREEMAN	SHEET NUMBER: 1 OF 1	