

# AMIGUARD

9000 SERIES VEHICLE BARRIERS



**AMIGUARD®**  
THE HIGH SECURITY  
CURTAIN WALL SYSTEM



**AMIGUARD® 9900 Series Wedge Barrier**

## Diamond Tough Perimeter Protection



# AMIGUARD® 9000 Series Vehicle Barriers



**With the addition of the AMIGUARD® 9000 Series Vehicle Barriers, AMICO Security is now offering manufacturing, integration, design and installation of crash rated anti-vehicular equipment solutions and expert technical support for government, industrial, commercial, and residential applications. The AMIGUARD® 9000 Series Vehicle Barriers are fully integrated with our Security fence product lines.**

Our team members have more than 20 years experience in partnering with contractors, installers, architects, and engineers to deliver high-quality designs, products, and services for complete

anti-vehicular solutions. Our products have a long track record of reliability in the marketplace from active bollards and wedge barriers, to passive systems like cable barriers and fixed bollards.

AMIGUARD® 9000 Series Vehicle Barriers from AMICO Security provide our customers with anti-vehicular equipment that puts an emphasis on reliability while keeping our products cost-competitive. AMICO Security takes great pride in designing and manufacturing security barriers that really stand up to the test. If you have a unique scenario, we can custom fabricate a security system to fit your needs.

## We focus heavily on manufacturing

### **Waterproof Motor**

- AMICO Security uses the latest design in electric motor operation. Many barriers provide IP68 water proof operation.

### **Dual Hit Defense**

- Many of our vehicle barriers can withstand multiple impacts, retaining function and protecting the site.

### **Hi-speed Operation**

- Our vehicle barriers use multiple types of operation systems; some of which are high speed while others are for heavy duty protection.

### **Flexible Operation**

- AMICO Security works with customers to determine the type protection required. Barriers are available with both electric and hydraulic operators to meet customer needs.







## AMIGUARD® 9100 Series Cable Systems

The AMIGUARD® 9100 Series Cable Systems meet the design appearance of surrounding fencing and gates while providing the protection desired.

- Can be integrated into AMICO Security fencing
- Available as stand alone crash protection to protect fencing
- Crash Rated M30 (K4)
- Decorative aesthetic finishes available



## AMIGUARD® 9310 Series Fixed Bollards

Fixed bollards are the staple of the security industry because they offer a high level of stopping power with minimal cost. Bollards can be fabricated, shipped, and installed quickly.

AMICO Security offers fixed bollards in crash ratings from M30 (K4) to M50 (K12). These bollards are capable of stopping a 15,000 pound vehicle at 30 mph, or capable of stopping a 15,000 pound vehicle at 50 mph. Standard fixed bollard designs allow the end user to arrange the bollards in different formations based on specifications and site conditions. AMICO Security's fixed bollards come in an assortment of aesthetic finishes from paint and powder coating to custom decorative finishes like aluminum or stainless steel.

- Simplistic installation with cost effective design
- US Department of State Crash Certified Designs M30 (K4) to M50 (K12)
- 30" – 39" above grade
- Decorative aesthetic finishes available



## AMIGUARD® 9320 Series Removable Bollards

If there are applications where infrequent vehicle access is required, the AMIGUARD® 9320 Series Removable Bollard provides the same crash rated protection and features as the 9310 Series Fixed Bollards with easy access.



## AMIGUARD® 9330 Series Shallow Mount Bollards

If there are applications where a 3-4 foot foundation cannot be achieved due to underground obstructions or utilities, the AMIGUARD® 9330 Series Shallow Mount Bollard with foundations of only 8"-12" in depth provides the same crash rated protection, look, and features as the 9310 Series Fixed Bollards without the deep excavation.

AMIGUARD® 9330 Series Shallow Mount Bollards may be ordered as individual units or several may be bolted together to form multiple bollard arrays. Factory applied zinc rich primer is applied in our in house paint facility before shipping.

- Shallow mount foundation
- Removable design available as AMIGUARD® 9340 Series
- Individual setting/ installation of each unit
- Modular Bolt-Together frames for custom configurations (optional)
- Custom Decorative Covers available





# AMIGUARD® 9000 Series Vehicle Barriers



## AMIGUARD® Active Barriers

Active barriers are essential to any project in the security industry. For any location needing vehicular access it is important to have an active system that is reliable. Factors to consider are cycle times, mode of operation (electric or hydraulic), and the number of vehicles entering/exiting per day.

The AMIGUARD® active barriers range from bollards to wedge barriers, crash gates and crash arms. They also come in different ratings from low rated models M30 (K4) designed to stop a 15,000lbs vehicle at 30mph, to M50 (K12) capable of stopping at 15,000lbs vehicle at 50MPH. The crash rating and style of the barrier changes depending on the site specifications as well as the specific type of application.



## AMIGUARD® 9350 Series Retractable Bollard

The AMIGUARD® 9350 Series Retractable Bollards are leading the industry in design and operation. There has never been an electric bollard with a fully waterproof motor/actuator, an M50 (K12) design that still works after a full scale crash test.

The AMIGUARD® 9355 Bollard is ASTM certified M50/P2 (K12). The full-scale crash test was conducted on only a single installed bollard which allows multiple bollards to be installed at any distance since each bollard is individually crash rated.

The bollard offers supreme protection and unique operation while mitigating the factors that traditionally create problems for automated bollards like water, ice, salt and sand. The AMICO Security bollard is a one of a kind system, and is guaranteed to provide any facility the look, operation and protection desired.

- Electric or Hydraulic Operation
- IP68 rated motor/actuator
- Still fully operates after crash
- Easy installation
- Low maintenance
- Aesthetic finish

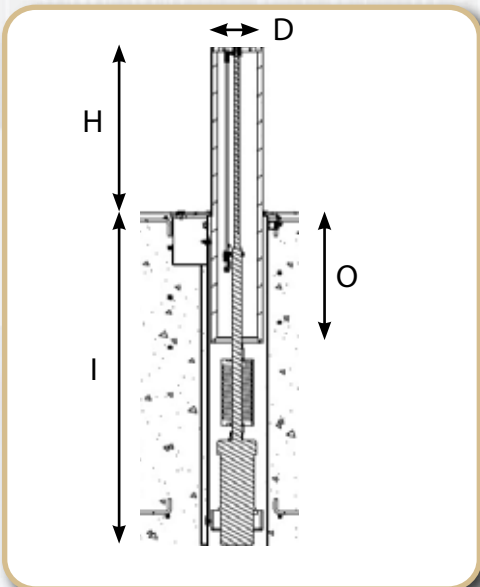

	AMIGUARD® 9353 Bollard	AMIGUARD® 9355 Bollard
Height above road (H)	27.5" (700mm)	35" (900mm) or 39" (1,000mm)
Diameter (D)	9" (220mm)	11" (270mm)
Inner receiver over lap (O)	12" (300mm)	27.5" (700mm)
Receiver height (I)	48" (1210mm)	72" (1,840mm)
Speed	3 seconds	5 seconds
Resistance	15,000 lbs/30mph	.072"
Operation	Hydraulic or Electric	Hydraulic or Electric
Finish	Stainless Steel or Powder Coated	Stainless Steel or Powder Coated
Options	Heating / LED Lights	Heating / LED Lights
MTBF	3 Million hr	3 Million hr
IP rating	IP68	IP68
Cycles per day	1,000	1,000

Also available as Fixed, Removable and Semi Automatic





## AMIGUARD® 9500 Series Crash Arms

The AMIGUARD® 9500 Series Crash Arms are the perfect anti-vehicular barriers for large openings or areas where snow and ice can affect areas under and around the barriers. Crash arms come with either manual or automated operation based on the frequency of use and desired application. Crash arms are offered as either vertical lift or swing arms and range in stopping power from a 15,000 pound vehicle at 30 mph to a 15,000 pound vehicle at 50 mph (M50/K12).

AMICO Security offers crash arms in widths up to 40', and they are available in electric, hydraulic, or manual operation. Crash arms are cost effective means of securing 1-3 lanes of traffic with a single barrier.

### Available Options:

- Traffic Lights
- Operator Heater
- Buttress Heater
- Electric motorized operation in lieu of hydraulic operation
- Crash Beam Magnetic Lock
- Crash Beam Flashing Light Kit
- Loop Detectors
- Master/Sub Control Panel
- Touch Screen Controls
- Manual Operation
- Galvanized or Primed and Painted Finish
- Low maintenance
- Aesthetic finish



## AMIGUARD® 9600 Swing Crash Gates

AMIGUARD® 9600 Series Swing Crash Gates are low cost options to cover a road. They are light weight and low maintenance. Swing Gates can also offer anti-vehicular and anti-pedestrian protection.

### Available Options:

- Crash Rated M30 (K4) to M50 (K12)
- Manual or Electric operation
- Traffic Lights
- 8' to 40' clear opening
- Loop Detectors
- Master/Sub Control Panel
- Touch Screen Controls
- Manual Operation
- Galvanized or Primed and Painted Finish
- Low maintenance
- Aesthetic finish
- Available with every AMIGUARD® mesh



AMIGUARD® 6100 mesh (shown in 1:1 scale)



# AMIGUARD® 9000 Series Vehicle Barriers

## AMIGUARD® 9700 Series Cantilever Crash Gates



The AMIGUARD® 9700 Cantilever Crash Gates are the perfect solution to protecting large areas with a single barrier. The cantilevered design allows for minimal excavation compared to other gates, and negates the need for a roadway embedded track. This allows larger vehicles to pass through the open area without fear of crashing the track of a rolling gate.



The AMIGUARD® 9700 Cantilever Crash Gates have a shallow foundation design compared to other crash rated gates, and the open box frame allows for any aesthetic design like any AMIGUARD® mesh to match the surrounding fence.



The AMICO Security Cantilever Crash Gates are available in widths from 10' to 40' and are certified with crash ratings from M30/P1 (K4) to M50/P1 (K12). Other options like integrated lights, remote control, touch screen controls, and photo-eyes are also available. The 9700 Cantilever Crash gate is a reliable low maintenance gate that will provide the security you need with the design flexibility to ensure it fits the look and specifications desired.

- Cantilevered Design (No roadway excavation required)
- Shallow Foundation with a 48" foundation design
- Available with crash ratings from M30/P1 (K4) to M50/P1 (K12)
- Hydraulic, Electric or Manual Operation
- Low maintenance
- Aesthetic Finish Options
- Available with any AMIGUARD® mesh



AMIGUARD® 6300 mesh (shown in 1:1 scale)

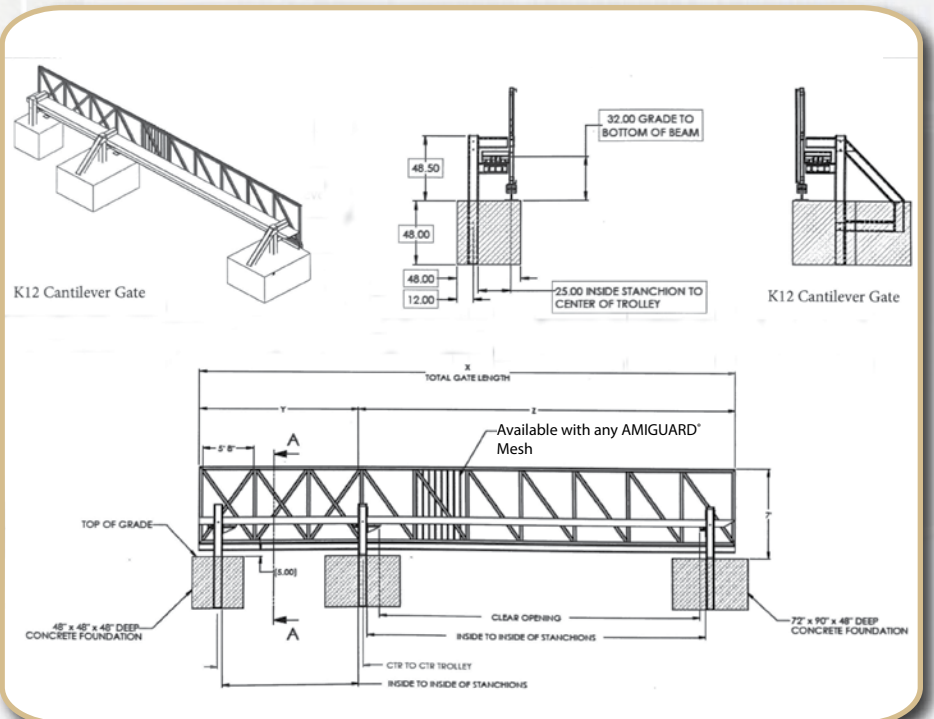



## AMIGUARD® 9900 Series Wedge Barriers

The AMIGUARD® 9900 Series Wedge Barriers are specifically built for the highest security and extreme reliability. The patent pending IP68 rated (waterproof) motor design ensures environmental conditions like water, ice, salt, and sand don't interfere with the barriers' operation.

The AMIGUARD® 9900 Series Wedge Barriers are ASTM Certified M50/P1 with zero penetration. After a full scale test the barrier will remain in the full upright secured position, ready to take another hit.

Available in widths from 8' to 15' with many different color options, the AMICO Security Wedge is guaranteed to provide any facility the look, operation, and protection desired.

- Electric or Hydraulic Operation
- Shallow Mount Foundation
- IP68 Rated Motor/Actuator
- Safety Lights

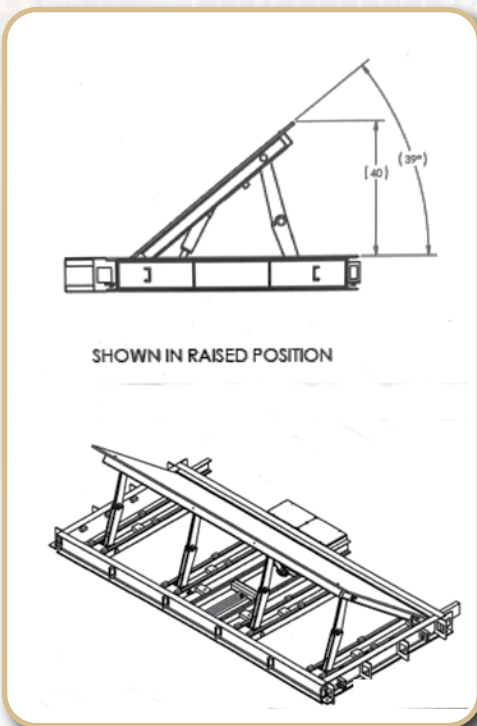

AMIGUARD® 9905 Wedge	
Height above road	39" (1,000mm)
Foundation depth	16" (400mm)
Speed	3 seconds
Resistance	15,000 lbs/50mph
Length	up to 15' (4,570mm)
Operation	Electrically Driven
Operations per hour	200
MTBF	3 Million hr
IP rating	IP68
Operations Temperature	-4 - +140°F (-20 - +60°C)



**AMICO Security**  
3245 Fayette Avenue  
Birmingham, AL 35208  
855-552-6426

[amicosecurity.com](http://amicosecurity.com)  
[info@amicosecurity.com](mailto:info@amicosecurity.com)  
[linkedin.com/company/amicosecurity](https://www.linkedin.com/company/amicosecurity)



**AMIGUARD® 9500 Series Crash Arm**



**[amicosecurity.com](http://amicosecurity.com) • 855-552-6426**