

AMIGUARD 8000 SERIES GATES



AMIGUARD®
THE HIGH SECURITY
CURTAIN WALL SYSTEM



AMIGUARD® 8500 Macro-Box Gate

Diamond Tough Perimeter Protection

AMIGUARD® 8000 Series Gates



AMICO Security is now a leading single-source provider of integrated access control solutions and expert technical support for industrial, commercial, and residential applications. The AMIGUARD® 8000 Series Gates are fully integrated with our Security fence product lines and AMIGUARD® meshes.

Since 1990 we have partnered with contractors, installers, architects, and engineers to deliver high-quality designs, products, and services for complete access control. Our knowledge and experience

is specialized across multiple security platforms ranging from residential lifestyle and community entry, to industrial and commercial access, to the most stringent high security protection demands.

AMIGUARD® 8000 Series Gates from AMICO Security provide security and access control for industrial, commercial and residential sites. Specify the gate alone, or request a complete, integrated solution with the gate operator and access control system that meets your project requirements. AMICO Security also offers gate customization services.

AMIGUARD® 8300 Swing Gates

High-Performance Features

- Durable aluminum construction to endure stresses, prevent rusting and extend the life of the gate operator
- The look of steel with the lighter-weight, corrosion-resistant, high-cycle operation
- All welded construction for greater frame strength and rigidity
- Precision-machined, permanently lubricated hinges for long-term performance
- Manual or automatic operation

Specifications

- For openings measuring from 3 ft. to 90 ft.
- Standard or micro-box frame
- Three-year limited warranty

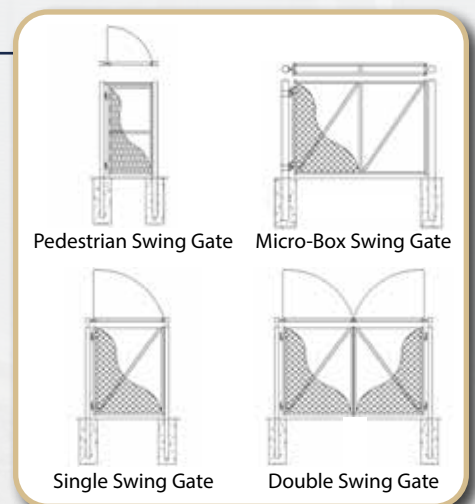



ANC Non Conductive Swing & Slide Gates

AMICO Security developed the ANC non conductive fence system as a total perimeter solution to offer a safe, aesthetically pleasing, non-conductive, radar friendly alternative to traditional fencing. The ANC Non Conductive Swing & Slide Gates are part of this non-conductive product family. ANC is growing rapidly in popularity and has many applications and advantages.

All ANC panels and the frame of the ANC Non Conductive Swing & Slide Gates are non-metallic and non conductive. Threaded fasteners bolt through the panels and tighten up securely using AMICO tamper-proof wedge plugs. Only a few hardware pieces such as hinges, the inside of the tracks and locks are actually metallic.

Secure substations, power facilities and energy companies throughout the world are becoming increasingly aware that ANC is the best solution to eliminate unforeseen occurrences related to touch and step potential.

ANC can help to ensure that power employees who work around and the general population living around substations are safer. Dielectric tests have been conducted by a certified laboratory in which leakage current and flashover voltage tests revealed NO electrical conductivity.

As the need for airport security increases, AMICO has the answer. Airports throughout the globe are searching for Perimeter Systems that won't interfere with radar signals. While traditional high security metal fencing system reflect radar, creating false images, ANC fencing doesn't show this interference. In addition to being safe and secure, ANC provides a clean aesthetically pleasing look that blends into the landscape.

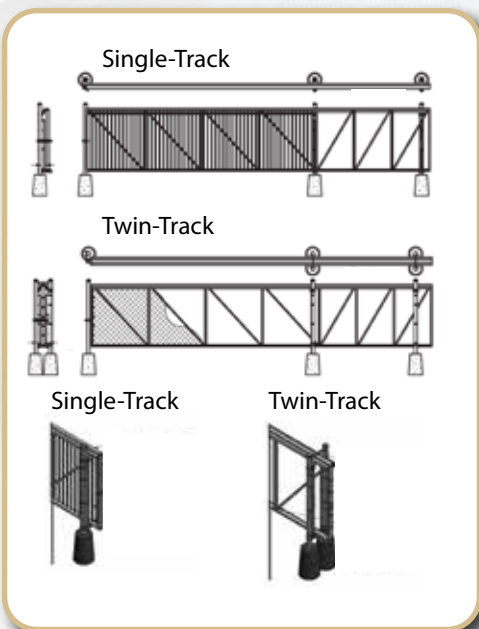

AMIGUARD® 8500 Slide Gates

High-Performance Features

- Durable construction to endure stresses and extend the life of the gate and gate operator
- The look of steel with the lighter-weight, corrosion-resistant, high-cycle, high-speed operation
- Robust movement mechanism for long-term performance
- Industry's heaviest and most robust enclosed track for safety, reducing liability risks
- Truck assembly with 2-inch, permanently sealed bearings for maintenance-free operation

Specifications

- For openings measuring from 10 ft. to 180 ft.
- Manual or automatic operation
- Single-track, twin-track, micro-box frame or macro-box frame system type
- Three-year limited warranty

Special Engineering Available

- Crash Rated slide gates up to 30 ft.
- Telescopic slide gates up to 250 ft.
- Rolling gates up to 600 ft.

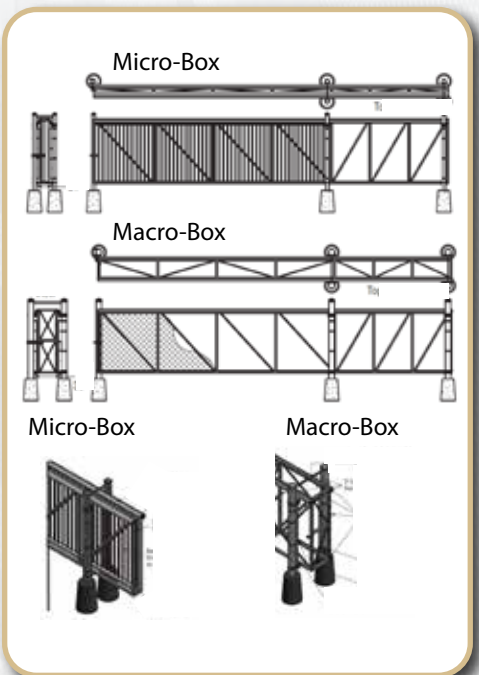

AMIGUARD® 8000 Series Gates



AMIGUARD® 8700 Turnstiles

The AMIGUARD® 8700 full height galvanized steel turnstile series provides superior access control through solid construction and safe design. These units are rated for outdoor use and come with hot dip galvanized powder coat finish. The mechanism components are aluminum and stainless steel.

This unit was developed with the installer in mind and can be assembled in a fraction of the time it takes to install comparable industry models. Should requirements change after installation, a user can easily change these units (that come electrically pre-configured) from fail-safe to fail-secure.

To prevent shock and vibration from transferring through the turnstile frame, all areas where mechanical impact occurs during normal operation (ratchets and mechanism mounts) are insulated with shock absorbing materials. This unique design assures a quiet and smooth operation of the turnstile and adds to the life of all mechanical parts.

Included with every turnstile are the following safety features: Heel protection, Home Position centering of spindle, Relocking timer and Anti-Passback preventing simultaneous passing of 2 people.



Gate Operators & Access Controls

Selecting from the highest-quality solutions available, we specify, provide and support only the best products for your application. We also ensure that all our solutions comply with the UL 325 safety standard.

AMICO Security delivers safe and efficient Gate Operators for reliable operation. Gate Operators include Slide Gate Operators, Swing Gate Operators, Hydraulic Gate Operators and Parking and Barrier Gate Operators. Available Access Control systems include Telephone & Digital Entry, Card Reader Systems, Vehicle ID Systems, Custom Camera Systems and Pad Locks.



Industry Leading Products

AMICO Security delivers safe and efficient solutions with industry leading products for reliable operation and access control.

- All-O-Matic
- AutoGate
- BAi – Barcode Automation
- BD Loops
- BFT
- Byan Systems
- Cartell
- Click2Enter
- DITEK
- DKS - DoorKing
- Diablo Controls
- EMX Industries
- FAAC International
- HID Global
- HySecurity/NICE
- LOCINOX
- Lockey USA
- MMTC
- Magnetic
- MillerEdge
- National Loop Co.
- Nortek Linear (OSCO)
- Northstar Controls
- OPTICOM
- Pedestal PRO
- Pro Access Systems
- RAE – Reno A&E
- RAI Products
- Ruscoe Highway Products
- SOS – Siren Operated Systems
- Seco-Larm
- SecuraKey
- Securitron
- Security Brands Inc.
- Select Engineered Systems
- USAutomatic
- Viking Access



AMIGUARD® 8000 Series Hardware Kit

The AMIGUARD® 8000 Series Hardware Kit contains all of the necessary hardware in compliance with ASTM 2200 and UL 325 standards.

Gate Hardware Kit

855-552-6426
amicosecurity.com

Adjustable Catch

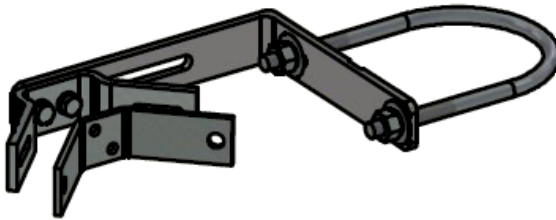

Truck Hanger Bracket



6-5/8" or 4" Round



Single Wheel Guide

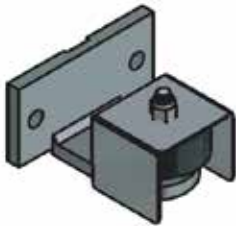

Double Wheel Guide

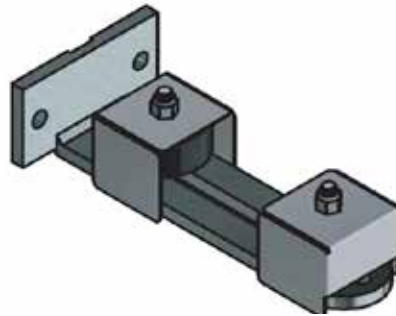

6" or 4" Square



U Bolts Options

Truck Assembly



Track Extrusion and Stop Assembly

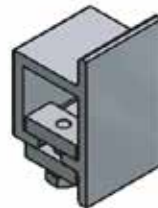

6-5/8" or 4" Round



Barb Arm Kit

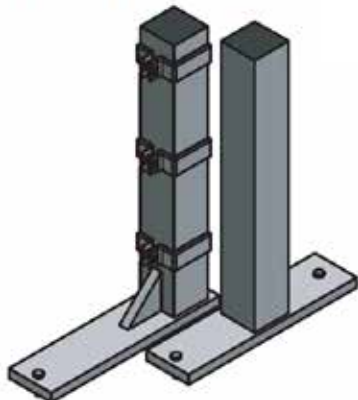

Tension Band

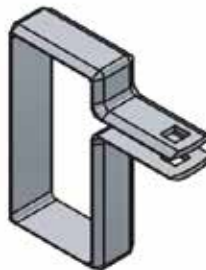

6" or 4" Square

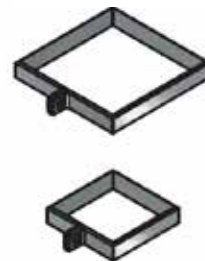

UL325 Baffle Kit

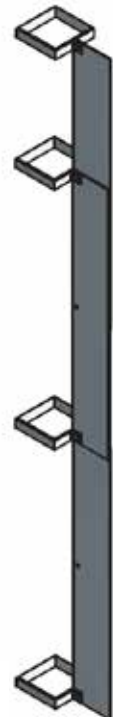

AMIGUARD® 6000 & 7000 Meshes

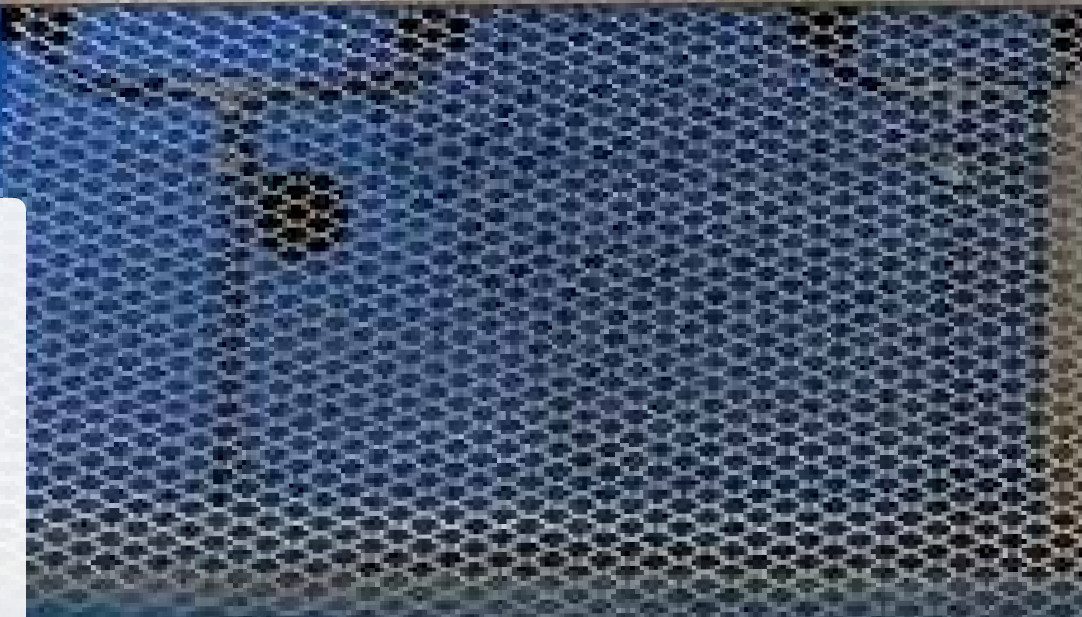

AMIGUARD®
THE HIGH SECURITY
CURTAIN WALL SYSTEM

Diamond Tough Perimeter Protection

855-552-6426
amicosecurity.com

Each AMIGUARD® 6000 Security Mesh and AMIGUARD® 7000 High Security Mesh panel goes through a process of slitting and stretching metal sheet to form the desired style. The Security Panel has strands and intersecting strands called bonds forming a sharp angle to the original plane of the solid sheet. This process creates the unique pattern and allows a single sheet of metal to be processed into several sheets of Security Mesh Panels.

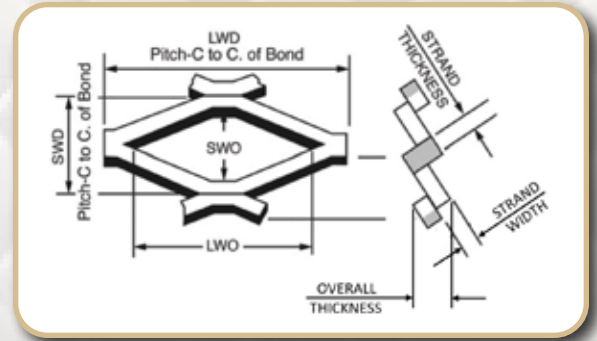

AMICO Security offers a wide range of AMIGUARD® 6000 Security Mesh and AMIGUARD® 7000 High Security Meshes. Meshes differentiate by weight and the size of the diamond openings. All meshes are available in Hot Dipped Galvanized or Black Powder coating over zinc primer/zinc e-coating.

AMIGUARD® Mesh Style	Short Way of Diamond	Long Way of Diamond	Strand Thickness	Strand Width	Percent Open Area	Weight per sq. ft. galv.
6030 (NEW)	1.85"	4.00"	.134"	.149"	84%	.990 lbs
6050 (NEW)	1.33"	3.00"	.134"	.144"	78%	1.31 lbs
6100	.500"	1.20"	.090"	.096"	62%	1.63 lbs
6200 (NEW)	.923"	2.10"	.108"	.165"	64%	1.75 lbs
6300	.923"	2.00"	.134"	.150"	67%	1.96 lbs
6800 (NEW)	1.33"	3.00"	.198"	.203"	69%	2.65 lbs
7100	.500"	1.20"	.090"	.188"	25%	3.10 lbs
7300 (NEW)	1.28"	3.00"	.075"	.600"	6%	3.18lbs
7500 (NEW)	.925"	3.00"	.090"	.400"	14%	3.50 lbs
7700	1.00"	2.40"	.179"	.240"	52%	3.76 lbs
7800 (NEW)	1.00"	2.25"	.179"	.250"	50%	3.92 lbs

Tolerances: Short Way of Diamond (SWD) & Long Way of Diamond (LWD) 0 + 0.25" per 12" of width.

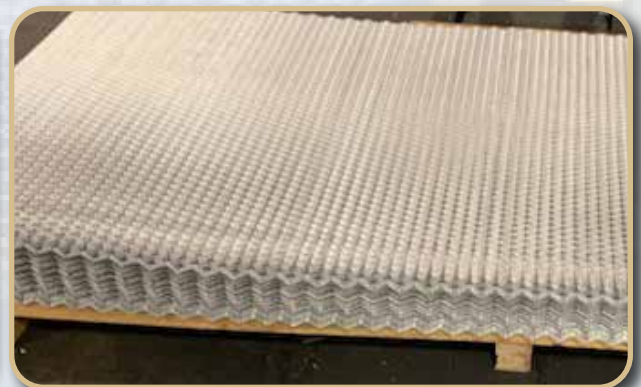

AMICO Security
3245 Fayette Avenue
Birmingham, AL 35208
855-552-6426

amicosecurity.com
info@amicosecurity.com
[linkedin.com/company/amicosecurity](https://www.linkedin.com/company/amicosecurity)

**AMIGUARD® 8500 Cantilever Gate with
AMIGUARD® 6100 Security Mesh**

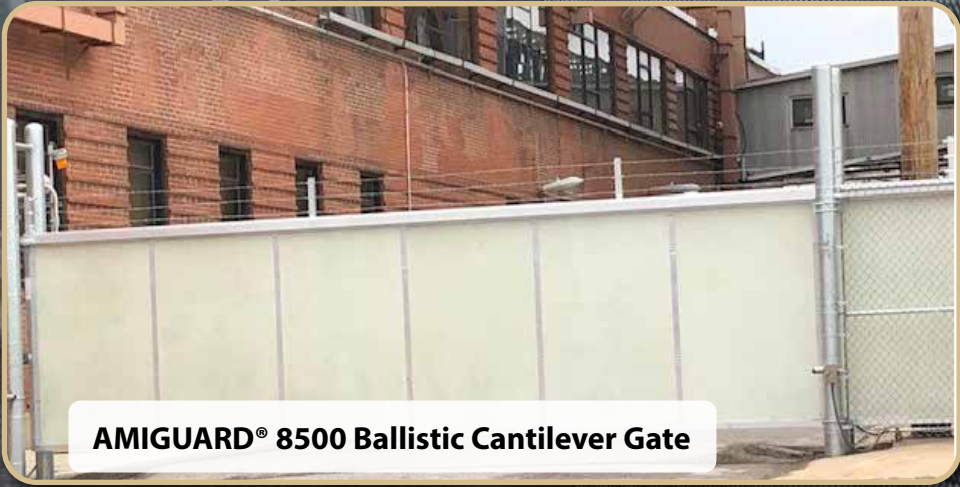

AMIGUARD® 8500 Ballistic Cantilever Gate



amicosecurity.com • 855-552-6426