

NOTES:

- 1.) Post size depends on fence height and wind loads. See ECHELON II™ post sizing chart.
- 2.) Panels also available for 6' on center post spacing
- 3.) Additional heights available on request. Some heights noted require a fourth rail.
- 4.) Fourth rail optional.

PANEL BRACKET

Specially designed two-point connection ensures fixity of rail ends for increased strength.

INTERNAL RETAINING ROD

Variable pitch connection system for ease of installation, high angle bias ability and elimination of unsightly external fasteners.

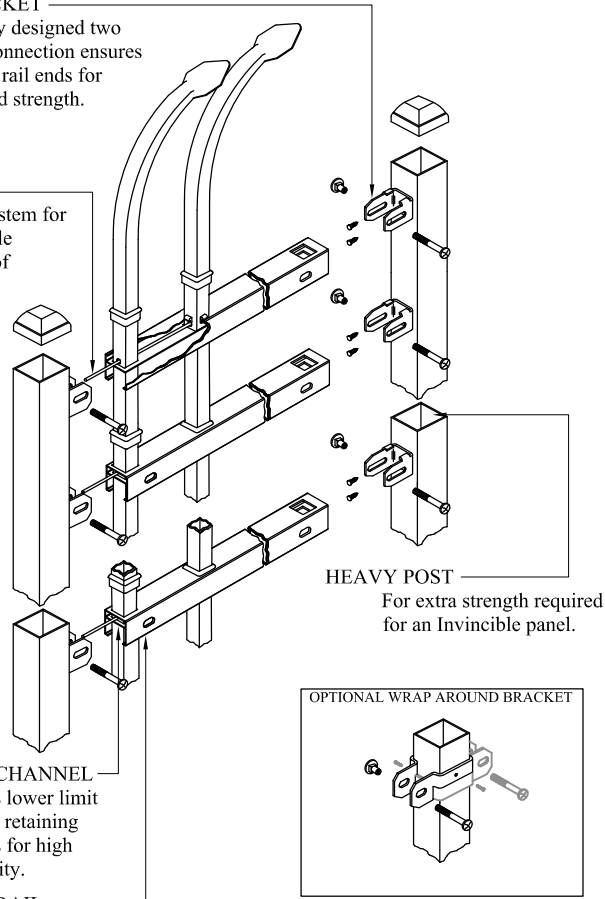
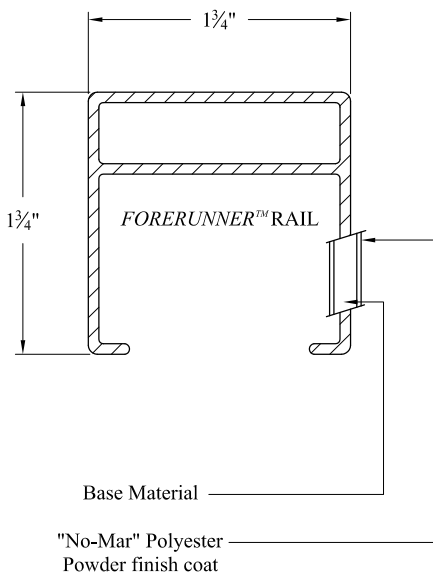

INTERIOR GUIDE CHANNEL
Channel forms lower limit of raceway for retaining rod and allows for high angle bias ability.

FORERUNNER™ RAIL
"U"-Channel specially formed high strength architectural shape.

Values shown are nominal and not to be used for installation purposes. See product specification for installation requirements.

INDUSTRIAL STRENGTH ALUMINUM

Title: **ECHELON II INVINCIBLE 3/4-RAIL**

DR: LJM SH . 1 of 1 SCALE: DO NOT SCALE

CK: BS Date 06-19-14 REV: G



AMERISTAR®

1555 N. Mingo
Tulsa, OK 74116
1-888-333-3422
www.ameristarfence.com