

Standard Heights  
 7' [2133.6mm],  
 8' [2438.4mm],  
 9' [2743.2mm],  
 10' [3048.0mm]

2" [50.8mm] Nom.  
 36" [914.4mm] Min.  
 Footing depth

- NOTES:**
- 1.) Post size depends on fence height and wind loads. See *AEGIS II* post sizing chart.
  - 2.) Additional heights available on request.
  - 3.) Third rail optional.
  - 4.) Panels also available for 6' on center post spacing.

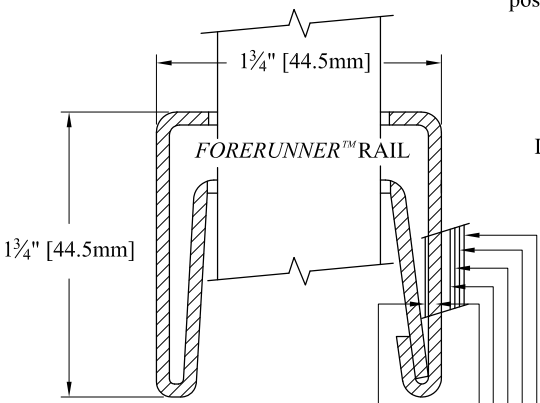

Uniform Zinc Coating (Hot Dip Galvanized)  
 Base Material  
 Uniform Zinc Coating (Hot Dip Galvanized)  
 Zinc Phosphate & Conversion Coating  
 Epoxy base coat  
 "No-Mar" Polyester Powder finish coat

**INTERNAL RETAINING ROD**  
 Variable pitch connection system for ease of installation, high angle bias ability and elimination of unsightly external fasteners.

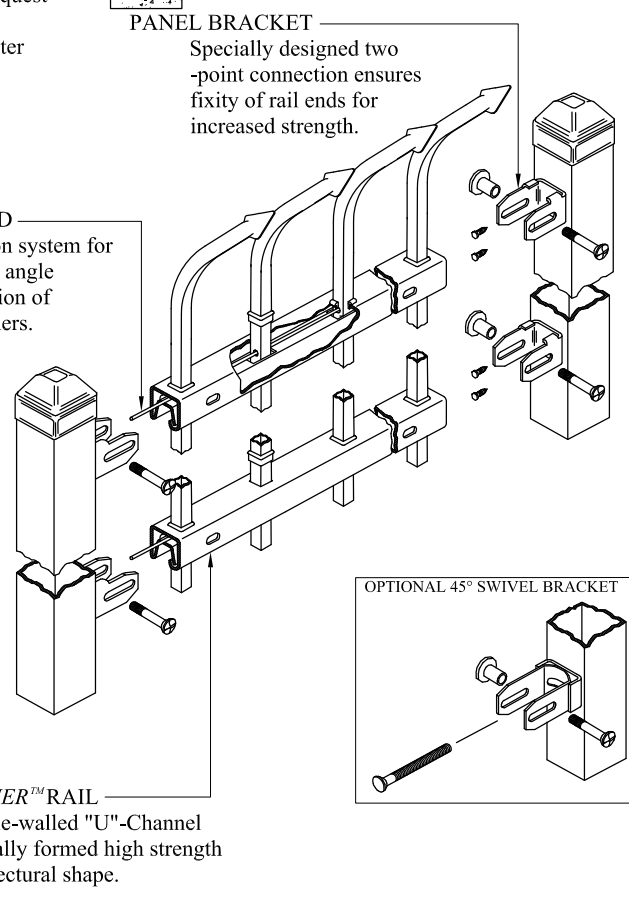

**INDUSTRIAL STRENGTH STEEL**

Values shown are nominal and not to be used for installation purposes. See product specification for installation requirements.

Title: <b>AEGIS II INVINCIBLE 2/3-RAIL</b>			
DR: KMc	SH . 1 of 1	SCALE: DO NOT SCALE	
CK:	Date 04/17/2015	REV: D	



**AMERISTAR®**

1555 N. Mingo  
 Tulsa, OK 74116  
 1-888-333-3422  
 www.ameristarfence.com