



AEGIS II[®] & AEGIS PLUS[®]

FORERUNNER[™] | ORNAMENTAL STEEL FENCE



AMERISTARFENCE.COM | 888-333-3422

Experience a safer and more open world

AMERISTAR[®]

ASSA ABLOY



POWERFUL PROTECTION & AGELESS AESTHETIC

The strength of *Aegis II*® & *Aegis Plus*® are rivaled only by the elegance of their profiles. Manufactured in both *industrial* & *commercial grades*, the Aegis steel products are designed for *strength & durability*. Balanced by the beauty of its design features, this family of Ameristar fence products matches the *level of security demanded* by your application but blends seamlessly into its surroundings with elevated *aesthetic appeal*.





Applications for Aegis II & Aegis Plus ornamental steel fence systems include:

- Stadiums*
- Water Districts*
- Public Housing*
- Retail Outlets*
- Multi-Family Housing*
- Self-Storage*
- Assisted Living*
- Municipal*
- Institutions*
- Manufacturing*
- Parks & Recreation*

AEGIS II[®]

INDUSTRIAL STRENGTH ORNAMENTAL STEEL

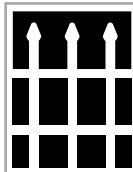

CLASSIC™

TIMELESS & ELEGANT

Extended pickets that culminate to an *arrow-pointed spear* capture the look of old style wrought iron fencing. *Single or double swing & slide gates* matching this fence style are also available.

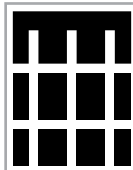

GENESIS™

PERSONALIZED & SECURE

Extended flat-topped pickets serve as a base for your *choice of accent finials* providing a customized design. *Single or double swing & slide gates* matching this fence style are also available.

ADORNMENTS

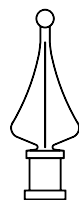

QUAD FLARE



TRIAD



ROYALTY



BALL POST CAP

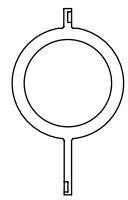

RING
(internally secured)

- ⇐ 1"sq. x 14ga. PICKETS
- ⇐ 1.75"w. x 1.75"h. x 14ga. FORERUNNER® RAILS
- ⇐ 2.5"sq. x 12ga. / 3"sq. x 12ga. POSTS
- ⇐ 3', 3½', 4', 5', 6', 7', 8', 9' & 10' FENCE HEIGHTS
- ⇐ 2 & 3 RAIL OPTIONS

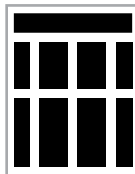

MAJESTIC™

SLEEK & MODERN

The *flush top rail* projects a more *modern, streamlined look* that beautifully accents any adjacent facility or the surrounding landscape. *Single or double swing & slide gates* matching this fence style are also available.

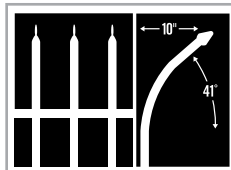

INVINCIBLE™

INTREPID & FORTIFIED

The *outward curve* of the pickets serves as a *graceful deterrent*, while *fortifying the perimeter* with elegant beauty. *Single or double swing & slide gates* matching this fence style are also available.

COLOR OPTIONS

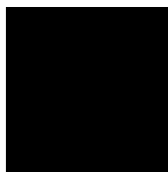

BLACK



BRONZE

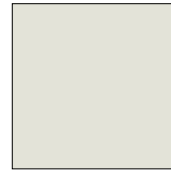

DESERT SAND

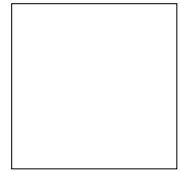

WHITE

AEGIS PLUS

COMMERCIAL STRENGTH ORNAMENTAL STEEL

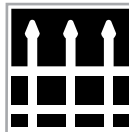

CLASSIC™

TIMELESS & ELEGANT

Extended pickets that culminate to an *arrow-pointed spear* capture the look of old style wrought iron fencing. *Single or double swing & slide gates* matching this fence style are also available.



GENESIS™

PERSONALIZED & SECURE

Extended flat-topped pickets serve as a base for your *choice of accent finials* providing a customized design. *Single or double swing & slide gates* matching this fence style are also available.

ADORNMENTS



QUAD FLARE



TRIAD



ROYALTY

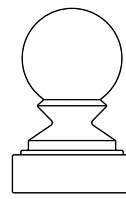

BALL POST CAP

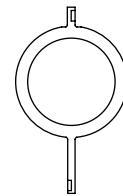

RING
(internally secured)

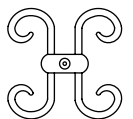

BUTTERFLY
SCROLL



- ⇐ .75"sq. x 17ga. PICKETS
- ⇐ 1.5"w. x 1.5"h. x 14ga. FORERUNNER® RAILS
- ⇐ 2.5"sq. x 12ga. / 3"sq. x 12ga. POSTS
- ⇐ 3', 3½', 4', 5', 6', 7' & 8' FENCE HEIGHTS
- ⇐ 2 & 3 RAIL OPTIONS

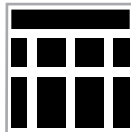

MAJESTIC™

SLEEK & MODERN

The *flush top rail* projects a more *modern, streamlined look* that beautifully accents flowers and shrubs when used as border landscaping. *Single or double swing & slide gates* matching this fence style are also available.



WARRIOR™

DISTINCTIVE & CLASSIC

Alternating heights of extended pickets that culminate to an *arrow-pointed spear* bring a hint of old-world elegance to this fence style. *Single or double swing & slide gates* matching this fence style are also available.

COLOR OPTIONS

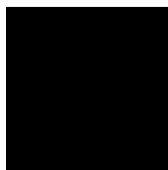

BLACK



BRONZE

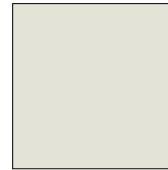

DESERT SAND



WHITE



FORERUNNER® INTERNAL LOCKING SYSTEM

Ameristar crafted the ForeRunner rail to *increase strength through architecture*. The innovative design feature of the ForeRunner rail is an *internally secured retaining rod* that allows for variable pitch connection, high angle biasability and eliminating unsightly external fasteners. *Galvanized inside & out* to protect against internal corrosion; the ForeRunner rail is in the upper echelon of perimeter security solutions.

INCREASED SECURITY

The ForeRunner Rail with internal retaining rod prevents the attachment from being compromised. Fasteners are not exposed.

AESTHETIC DETAILS

“Good Neighbor Design” retaining rod follows ForeRunner centerline providing a clean and uninterrupted look void of visible screws or rivets.

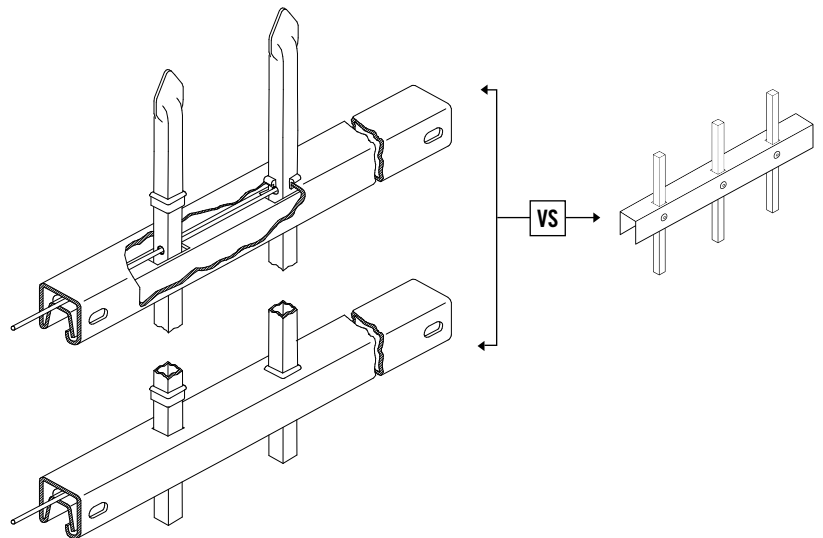

RAKEABLE VS STAIR-STEP

Aegis II & Aegis Plus feature a unique picket to rail connection method that allows for biasability of up to 25% eliminating the need for the unsightly stair stepping of panels.

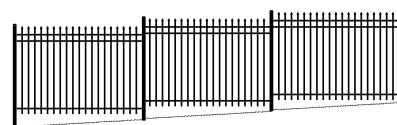

Stair-stepping panels

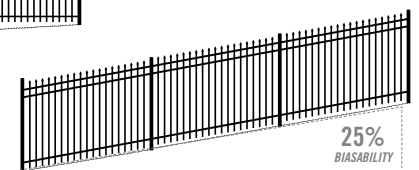

Fully rakeable panels



GROMMET

Aesthetic appearance while preventing moisture collection.

INTERNAL RETAINING ROD

Variable pitch connection system provides ease of installation, high angle biasability and eliminates unsightly external fasteners.

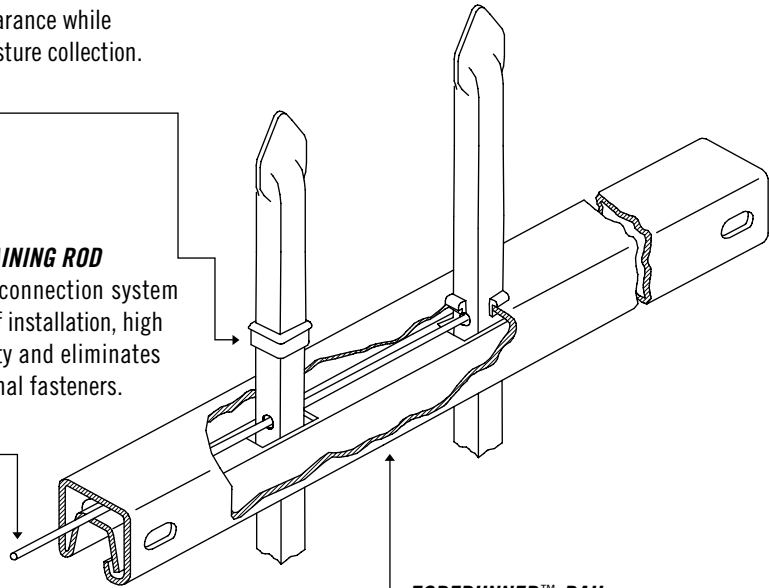

FORERUNNER™ RAIL

“U” Channel is a specifically formed, high strength architectural shape

PANEL BRACKET

Universal Boulevard™ Bracket enables easy installation while allowing for adjustment of panel height and positioning

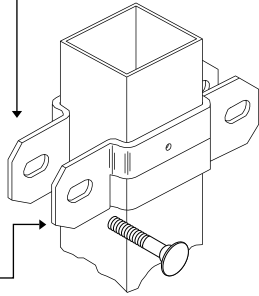
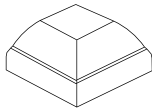

SECURITY FASTENERS

Security fastener secures the rail and deters removal by typical tools





PERMACOAT™

The majority of Ameristar products are protected by the unique PermaCoat process. Our **PRE-GALVANIZED STEEL BASE MATERIAL** is subjected to an **11-STAGE PROCESS** to cleanse & prepare the steel for a **DUAL TOP-COAT FINISH**. PermaCoat's corrosion resistant abilities far surpass those of painted surfaces and have a "no-mar" polyester powder top coat. This dual coating not only provides **RESISTANCE FROM WEATHERING** but also reduces scratch & burnishing marks typically encountered during shipping.

PRE-TREATMENT

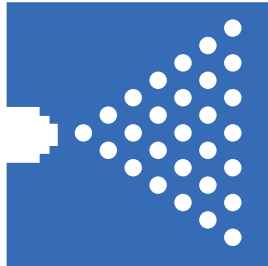

ALKALINE WASH

Cleans metal for proper adhesion of phosphate

1

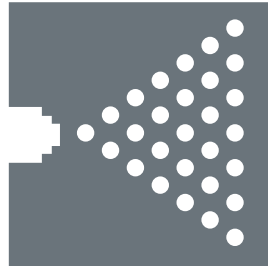

FIXIDINE RINSE

Rinses excess alkaline prior to phosphate application

2

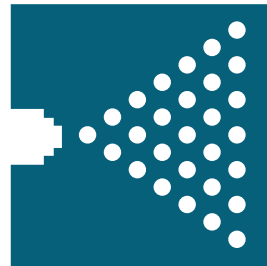

PHOSPHATE RINSE

Corrosion resistant layer that assists in bonding powder coating

3



CLEAR WATER RINSE

A bit of clean H2O to prep for the next phase

4

DOUBLECOATING

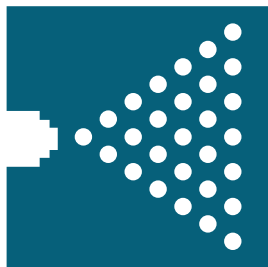

EPOXY POWDER COAT

Epoxy powder is electrostatically applied

8



EPOXY GEL OVEN

Powder is gelled & cured to finish coat

9

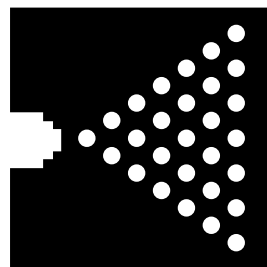

POLYESTER POWDER

TGIC powder is electro-statically applied

10



FINISH CURING OVEN

Seals finish for years of maintenance free use

11

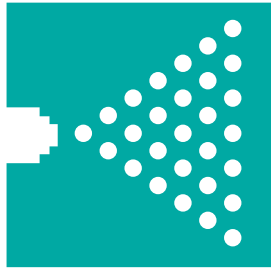
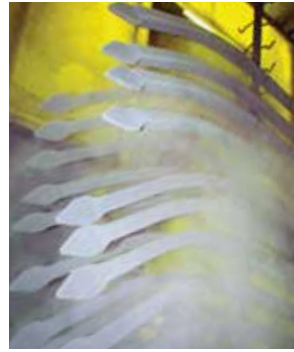

NON-CHROMATE SEAL

Barrier to prevent moisture from reaching base metal

5



CLEAR WATER RINSE

Final wash in H2O to remove any excess debris or particles

6



DRYING OVEN

Eliminates all moisture prior to double coating

7

ONCE COMPLETED, THESE 7-STAGES WILL HAVE REMOVED EVERYTHING FROM THE SURFACE OF THE STEEL THAT MIGHT INHIBIT THE FINISH FROM PROPERLY ADHERING DURING THE NEXT 4-STAGES OF THE COATING PROCESS.

Corrosion occurs more easily without the proper preparation & protection, which is why Ameristar has put our fence products to the test based on ASTM B117 standards. *The results speak for themselves.*

CORROSION TESTING



PAINTED STEEL



PRIMED & PAINTED STEEL



SINGLE COAT PROCESS
Iron Phosphate + Polyester Powder Coat



SINGLE COAT PROCESS
Phosphate Rinse + Polyester Powder Coat



PERMACOAT PROCESS
Phosphate Rinse + Epoxy Powder Coat + Polyester Powder Coat

STEEL RAIL STRENGTH COMPARISON

STRUCTURAL PARAMETERS FORERUNNER™ AEGIS II® SQUARE RAIL INDUSTRIAL FORERUNNER™ AEGIS PLUS® SQUARE RAIL COMMERCIAL U-CHANNEL COMPETITORS

Architectural Profile of rail shape.
Vertical Design Loads are per rail.
 (For capacity of fence panel, multiply by number of rails)

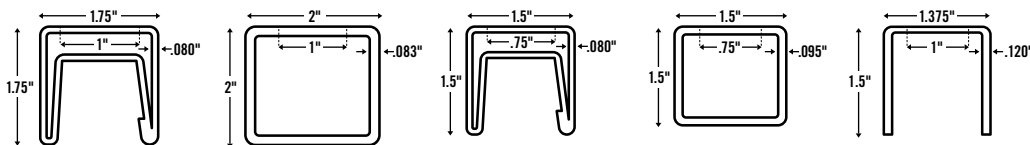

T_{eff} = Effective Wall Thickness (inches)		.160	.083	.160	.095	.120
S_v = Section Modulus (inches vertical)		.1624	.188	.1612	.115	.0938
S_h = Section Modulus (inches horizontal)		.367	.309	.254	.147	.210
Vertical Load Data PV_f = Ultimate Vertical	6' span	676#	523#	652#	320#	n/a
	8' span	506#	392#	492#	239#	229#
Horizontal Load Data PH_f = Ultimate Horizontal	6' span	1,020#	859#	639#	409#	n/a
	8' span	765#	644#	482#	306#	438#
Vertical Load Data* PV_d = Vertical Design Load @ 66° F_y	6' span	446#	345#	430#	211#	n/a
	8' span	334#	259#	325#	158#	151#
Horizontal Load Data* PH_d = Horizontal Design Load @ 66° F_y	6' span	673#	567#	422#	270#	n/a
	8' span	505#	425#	318#	202#	289#

* Recommended load value for safe structural design / allowable strength = .66° F_y





10 YEAR LIMITED WARRANTY

The family of Aegis steel fencing products are manufactured from premium materials by skilled craftsmen to meet the highest standards of workmanship in the industry. This is why Ameristar proudly offers a limited 10-year warranty.



DOMESTIC MANUFACTURING

Ameristar is committed to providing products that are manufactured in the USA. We have made significant investments in technology, process improvement, and employee training in an effort to secure American jobs and combat inferior import products.



ENVIRONMENTALLY RESPONSIBLE

Ameristar proudly leads the way in manufacturing programs and practices to reduce its carbon footprint and has implemented methods for reducing energy consumption. Contact your Ameristar Representative today to discuss how Ameristar products have the opportunity to earn LEED points.



EXODUS EGRESS GATES

ALL-IN-ONE PEDESTRIAN GATE SYSTEMS

- PRE-INSTALLED HARDWARE
- SINGLE & DOUBLE OPTIONS
- RIGHT & LEFT HAND OPTIONS
- THREE MOUNTING OPTIONS
- QUICK INSTALL



SLIDE GATES & SWING GATES

Egress & ingress requirements are unique to each application. *Managing traffic flow & usage demands* are of the utmost importance, which is why Aegis is manufactured in a variety of gate types built to *balance function, security & beauty*.

Ameristar *Transport™* & *Passport™* sliding gates perfectly match the perimeter fence system to create a *seamless & stunning design* while exuding a *commanding presence* of security built to unite perimeter and entry.



WHY CHOOSE AMERISTAR

KNOWLEDGE & EXPERIENCE

Ameristar was chartered over *30 years ago* in response to the *demand by consumers & specifiers for specialty fence products*. Ameristar offers an *aesthetically pleasing product* that is both *high in quality & affordability*. This has been achieved by maximizing *high-volume productivity*, increasing product design strength, and promoting *simplistic installation*.

PROVEN CAPABILITY

Ameristar's integrated *in-house process & extensive raw material inventory* results in much improved productivity and availability compared to the competition. By having a *vast finished goods inventory*, Ameristar is capable of *delivering finished products faster* than competitors who sublet the majority of their operations.

INDUSTRY LEADERSHIP

Over the years Ameristar has continually *raised the bar* across the board in the *manufacturing of high quality*, innovative fencing products. Our demonstrated commitment to *upholding higher values* translates into superior products that *go far beyond* merely meeting minimum industry standards.



Ameristar's world headquarters, manufacturing & coil processing facilities in Tulsa, Oklahoma, USA.

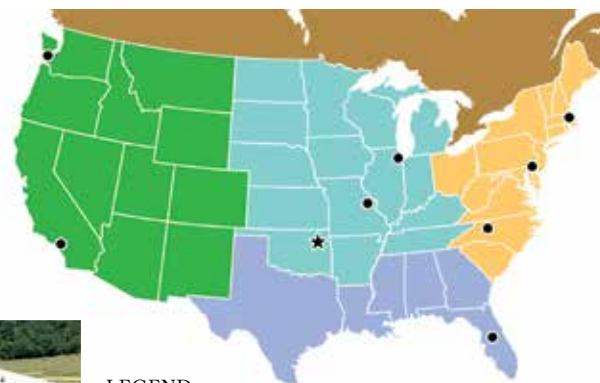

LEGEND

- ★ Ameristar Headquarters
- Sales & Service Centers

#9721 | REVISED 01/2020



AMERISTARFENCE.COM | 888-333-3422

Experience a safer and more open world

AMERISTAR[®]

ASSA ABLOY