

## Test Report - Commercial in Confidence W0017 PAS68 N3 Rapid Deployment Barrier

Test Laboratory	HORIBA MIRA Ltd
Date of Report	24/04/2019
Client	GD Tech S.A
Test Item	F18 Steel rapid deployment system
Date of Test	26/02/2019
Test Number	W0017
Report Number	PAS68 1219545-002-02
Test Type	Vehicle Impact
Product Rating	PAS68:2013 Barrier V/7500(N3)/48/90:28.1/18.0
Number of Pages	20

Prepared By:

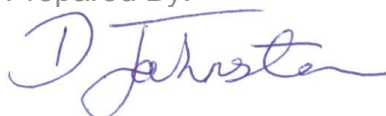

Dave Johnstone  
Consultant, HSPI Test Centre

Approved By:



Rachael Kennedy  
Head of HSPI Test Centre

Date: 24<sup>th</sup> April 2019



1105

# Contents

	Page	
1	Introduction	3
1.1	Test laboratory	3
1.2	Product Manufacturer	3
1.3	Client	3
1.4	Test Procedure	4
2	Test Set-up	4
2.1	Product Description	4
2.2	Foundation/Installation Description	4
2.3	Test Vehicle Description	5
3	Test Results	6
3.1	General	6
3.2	Test Sequence Description	6
3.3	Ambient Conditions*	6
3.4	System Damage Description	7
3.5	Vehicle Damage Description	7
4	Conclusions	7
5	General Comments and Disclaimers	7
6	Side Views from High Speed Videos	8
7	Overhead Views from High Speed Videos	9
8	Post Impact Product and Vehicle Images	10
Appendix 1	Executive Summary	11
Appendix 2	Product Drawings and Details	12
Appendix 3	Test Vehicle Details	18
Appendix 4	Calibration Information	19
Appendix 5	Revision History	20

# 1 Introduction

## 1.1 Test laboratory

Name	HORIBA MIRA Limited
Address	Watling Street, Nuneaton, Warwickshire, CV10 0TU. United Kingdom
Telephone number	+44 (0)24 7635 5000
Facsimile number	+44 (0)24 7635 8000
Internet address	www.horiba-mira.com
Test site location	At above address.
Accrediting body	United Kingdom Accreditation Service 21-47 High Street, Feltham, Middlesex. TW13 4UN
Accreditation details	HORIBA MIRA is designated as UKAS testing laboratory 1105, with approval dated 31 July 1992, subsequently renewed periodically, for details of the latest approval, and schedule of accreditation see: <a href="http://www.ukas.org/testing/lab_detail.asp?lab_id=826">http://www.ukas.org/testing/lab_detail.asp?lab_id=826</a>

## 1.2 Product Manufacturer

Name	Pitagone SA/NV
Address	Paepsem Boulevard 16 1070 Brussels Belgium
Internet address / email	marcw@pitagone.com
Type	Barrier
Model No	PITAGONE F18

## 1.3 Client

Name	GD Tech SA	
Address	7 Avenue De L'Expansion, Liège, 7 – B-4432	
Internet address / email	marcw@pitagone.com	
Additional information	Purchase order:	TURA/2019/002
	Client Engineer:	Marc Weissberg

## 1.4 Test Procedure

Item	Requirement
Test Specification	PAS68: 2013
Target Speed (km/h)	48.0 ±3.0
Target Impact Angle (deg)	90.0 ±2.0
Target test vehicle mass (kg)	7500 ±150
Barrier Classification	A-Foundation/Passive/Barrier
Target Impact Energy (kJ)	666.7

## 2 Test Set-up

### 2.1 Product Description

The tested item was a PITAGONE F18 steel rapid deployment barrier system manufactured and installed by Pitagone SA/NV.

This consisted of 8 x steel ‘L’ shaped barrier with square and round tube connectors set at the 250mm gap between barrier uprights. These were held in place with pins with retractable ball bearings on lanyards. On the lower front there was a crush tube with a spike inside and wheels on the lower part of the system for aiding with positioning or moving.



### 2.2 Foundation/Installation Description

The test items were placed on smooth level tarmac surface free of water with no pinning or connection to any other item.



## 2.3 Test Vehicle Description

Item	Information / Measurement
Vehicle Make and Model	DAF 55
Registration Mark and VIN	MX09FRO / XLRAE55GF0L352850
Engine	Diesel
Gearbox	Manual
Body Type	Flatbed
Delivery Mass (kg)	6466
Test Mass (kg)	7508
Ballast (kg) – 1x concrete blocks, chains and ratchets	1010
Test Equipment (kg) – DTS, GPS, Remote Braking	50
Components Removed (kg) – Side underrun bar	18
Test Vehicle condition	Test vehicle acquired with valid current MOT certificate. The roadworthiness of the following items was checked prior to test: Tyres and wheels, Suspension, Wheel Alignment, Bodywork, Brakes and Chassis. The engine was running for the test.



### 3 Test Results

#### 3.1 General

Item	Information / Measurement
Test Number	W0017
Test Date	26/02/2019
Impact Angle (deg)	89.6
Impact alignment (mm)	44 Left
Impacted height (mm)	675
Impact velocity (km/h)	47.8
Impact energy (kJ)	0.0
Vehicle penetration - dynamic (m)	28.1
Vehicle penetration - static (m)	28.1
Clear gap >1200mm at 600mm above ground?	Yes
Debris ejected?	18m, 1 unit
Vehicle disabled?	Yes

#### 3.2 Test Sequence Description

The test vehicle centreline was aligned to the middle of the deployed units. Upon impact the units rotated forward with the rear lower spikes digging into the ground and the units coming into contact with the underside of the vehicle and engine. The front axle lifted off the ground and the units were pushed forward. As the units were pushed they became separated and rotated. The vehicle dropped back down onto the units which then came into contact with the prop shaft causing more damage to the test item and lifting the rear axle from the floor. The vehicle then slowed coming to a halt with 28.1m of penetration.



#### 3.3 Ambient Conditions\*

Item	Measure
Rainfall (mm)+	0.0
Temperature (°C)	12.0

\* Weather records are not UKAS accredited

+From midnight to time of test

### 3.4 System Damage Description

2 units remained trapped under the vehicle, 5 units were attached together 16m into the incident with the link bars twisted and some torn through the drilled pinning points. 1 unit was at 18m forward and 2.5 m to the left of target impact point. All of the units had suffered damage from the impact to varying degrees including all the positioning wheels which were all damaged, rear ground hooks were bent and powder coating damage with some twisting of the main structures.



### 3.5 Vehicle Damage Description

The front cosmetic panels suffered damage. As did the front bumper. Front driver side tyre was cut. The engine sump was torn open allowing engine oil to be distributed along the floor. The engine was still running and allowed for a follow on attempt which failed due to the 2 units underneath becoming entangled and causing the wheels to loose traction. The centre and rear prop shaft bearings were also damaged along with marking on the prop shaft itself. The Ad-Blue tank was torn from its mountings and the rear exhaust silencer was detached.



## 4 Conclusions

The Pitagone SA/NV F18 steel rapid deployment barrier system was assessed according to PAS68:2013 and achieved the following classifications:-

Product Classification	A-Foundation/Passive/Barrier
Performance Classification	PAS68: 2013 Barrier V/7500[N3]/48/90:28.1/18.0

## 5 General Comments and Disclaimers

The installation of the product was the responsibility of the product manufacturer or their representative.

The test results in this report relate only to the product tested.

This report may not be reproduced other than in full, except with the prior written approval of the issuing laboratory.

Opinions, interpretations and meteorological information included in this report are not part of the UKAS accreditation and are marked thus \*.

## 6 Side Views from High Speed Videos





# 7 Overhead Views from High Speed Videos



# 8 Post Impact Product and Vehicle Images



# Appendix 1 Executive Summary

## Manufacturer Details

Company Name	Pitagone SA/NV
Company Address	Paepsem Boulevard 16 1070 Brussels Belgium
Contact Name	Marc Weissberg
Contact Email	marcw@pitagone.com

## Test Item Details

Item Reference	PITAGONE F18
Item description	Steel rapid deployment system x 8
Width (mm)	4248 (All 8 Units)
Thickness (mm)	1030 (front tip to rear spike)
Height (mm)	1000
Installation Date	26/02/19
Concrete Strength (MPa)	n/a

## Test Parameters

	Requirement	Measured Value
Test Vehicle category	N3	N3
Test Mass (kg)	7500 ±150	7508
Impact Speed (km/h)	48 ±3	47.8
Impact Angle (deg)	90 ±2	89.6
Alignment (mm)	-	44 Left
Vehicle penetration – dynamic (m)	-	28.1
Vehicle penetration – static (m)	-	28.1
Major Debris ejection distance (m)	-	18.0
Vehicle disabled?	-	Yes
Follow-on vehicle encroachment possible?	-	No
Follow-on pedestrian encroachment possible?	-	Not assessed

## Performance Classification – Vehicle Impact

Performance classification	PAS68:2013 Barrier V/7500[N3]/48/90:28.1/18.0
Product classification	A-Foundation/Passive/Barrier

# Appendix 2 Product Drawings and Details

No. ARTICLE	NUMERO DE PIECE	Quantité
1	Pieds Portique AC 18T - V2	1
2	Tube Verrouillage Croix	2
3	ASM Roues	1
4	AXE 9.5mm - 146mm - A BILLE	2
5	AXE 9.5mm - 100mm - A BILLE	8
6	TUBE PROTECTION POINTE	1

A	21/03/2017	Création.							
<b>Rév.</b>	<b>Date</b>	<b>Description</b>	<b>Demanded For:</b>						
REVISIONS									
CLIENT: PITAGONE									
<b>PITAGONE F18</b>									
REFERENCE INTERNE:									
DESCRIPTION:									
MASSE: 36.96 Kg									
MATIERE:									
FINITION / COULEUR:									
EPAISSEUR TOILE: mm									
ECHELLE: 1:5									
PAGE: 1/4									
REVISION: A									
DATE: 20-12-18									
CONCEPTEUR: GGH									
FORMAT: A3									



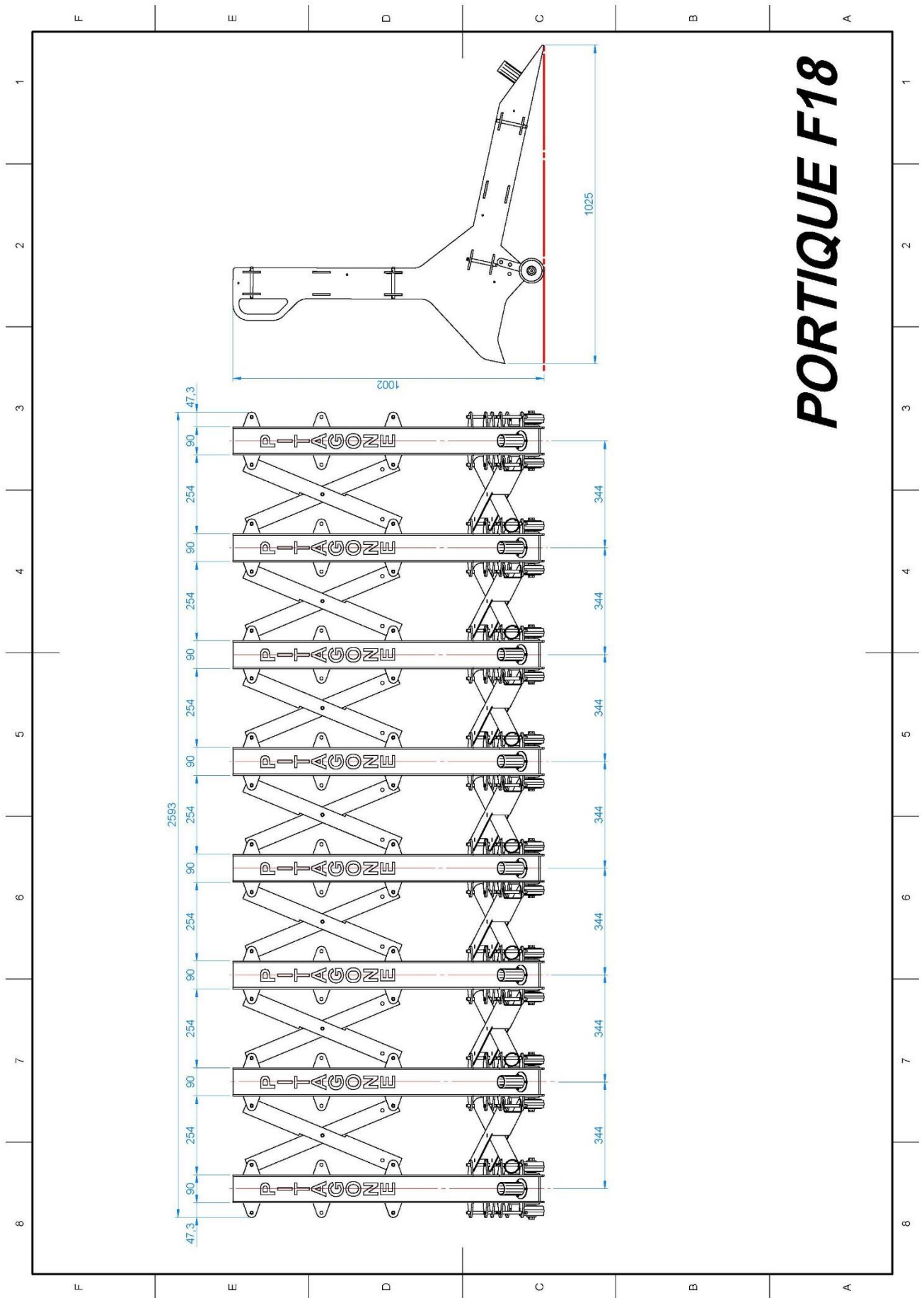

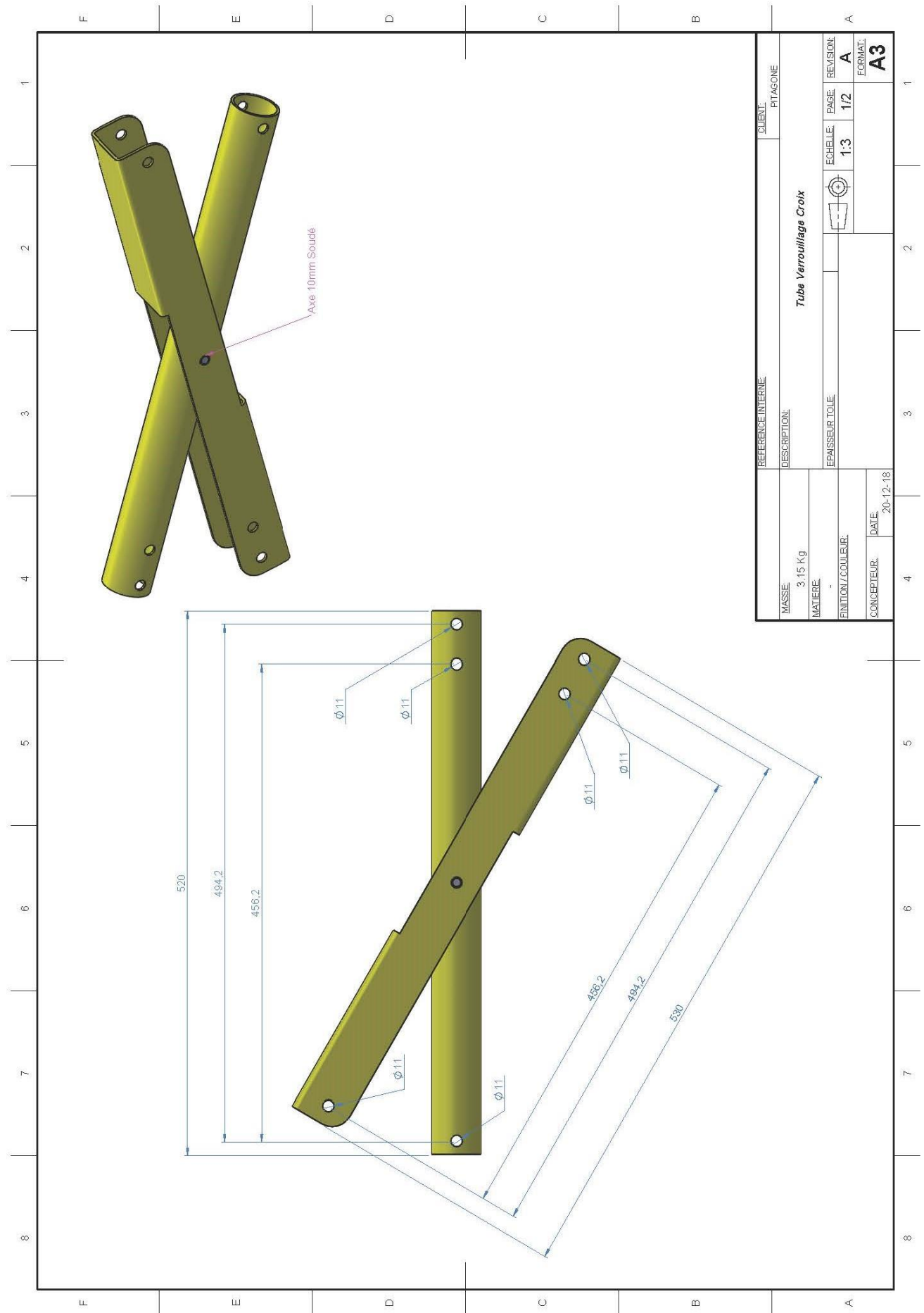

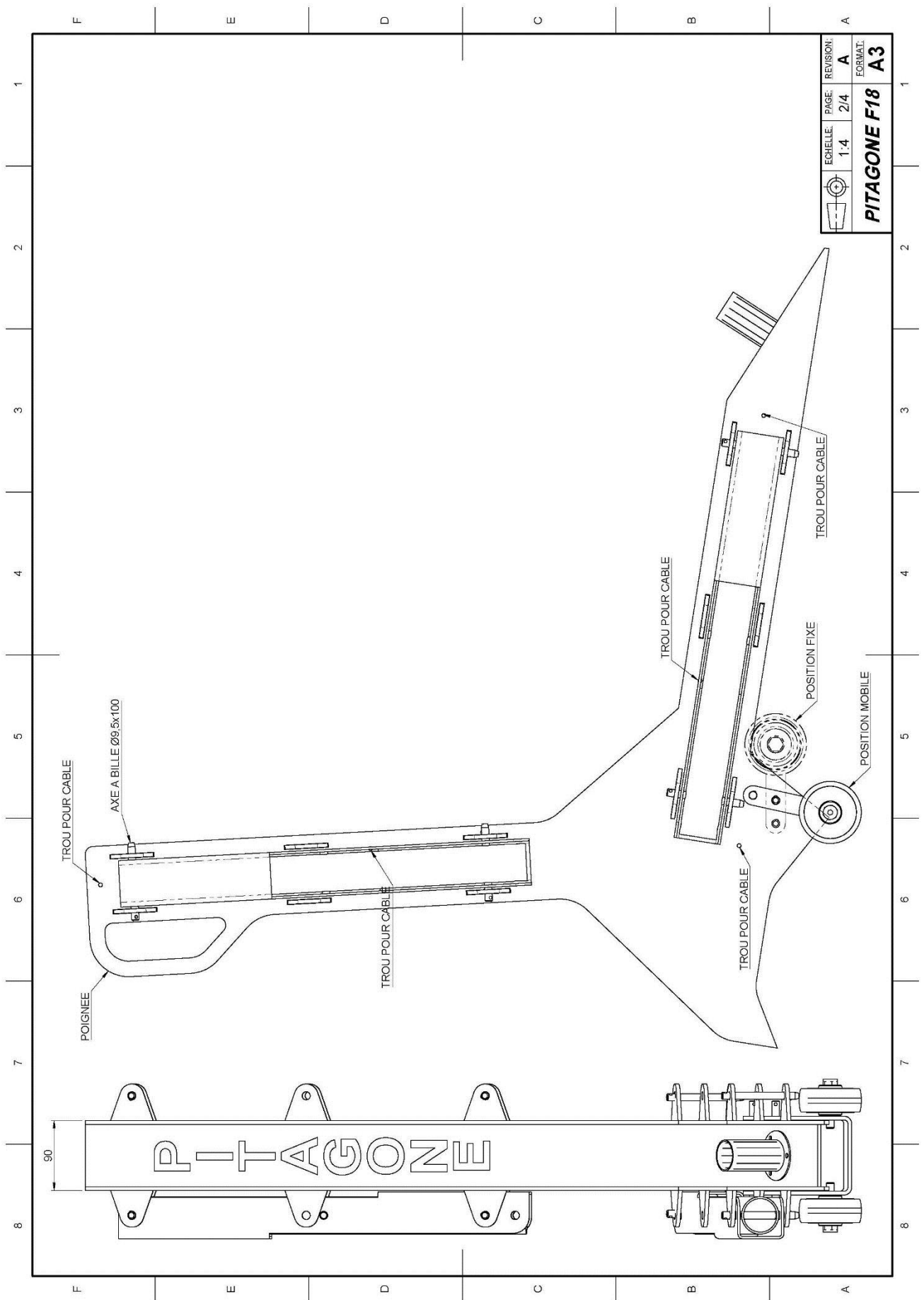
	ECHELLE:	PAGE:	REVISION:
	1:4	2/4	A
<b>PITAGONE F18</b>			FORMAT:
			<b>A3</b>

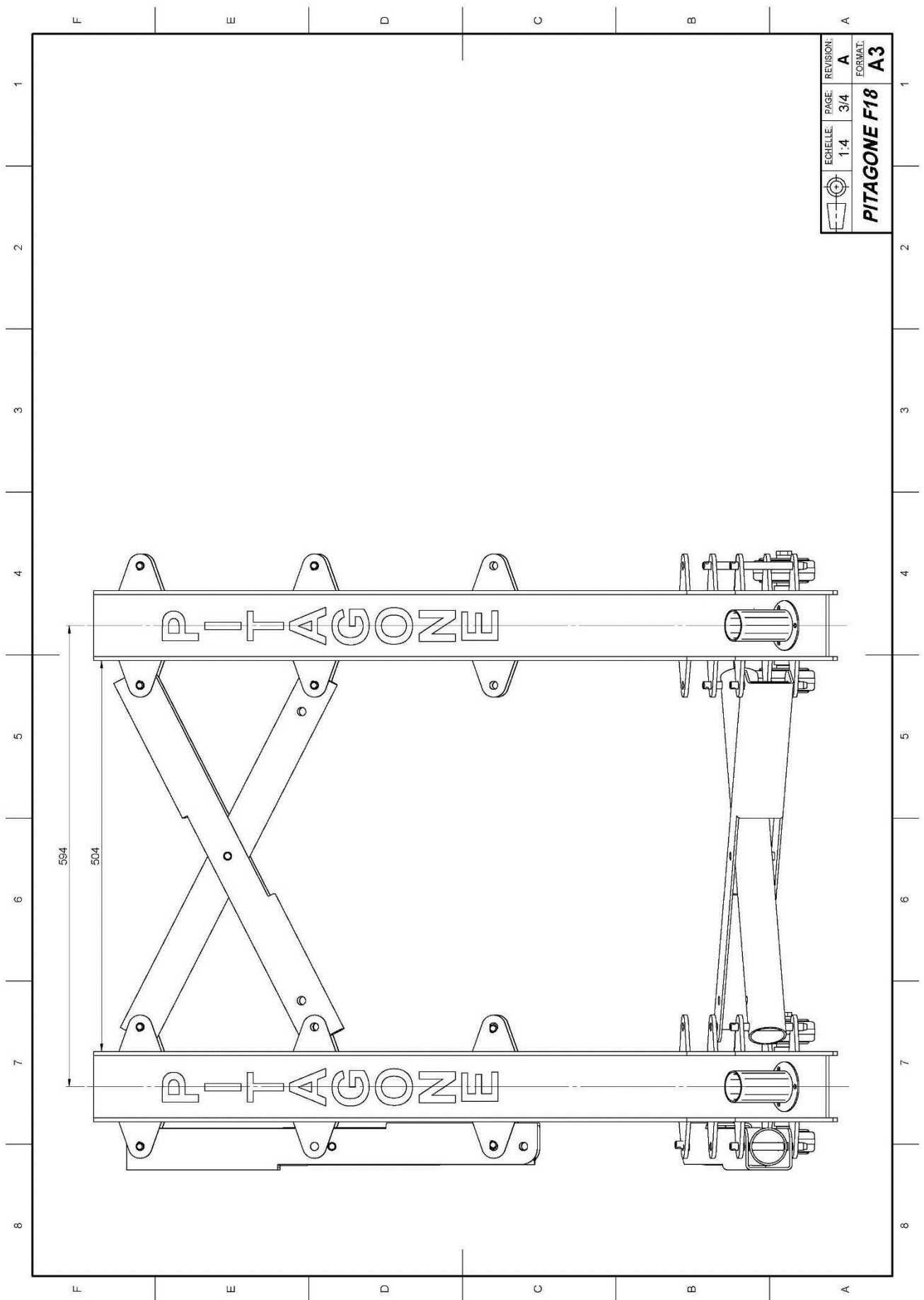



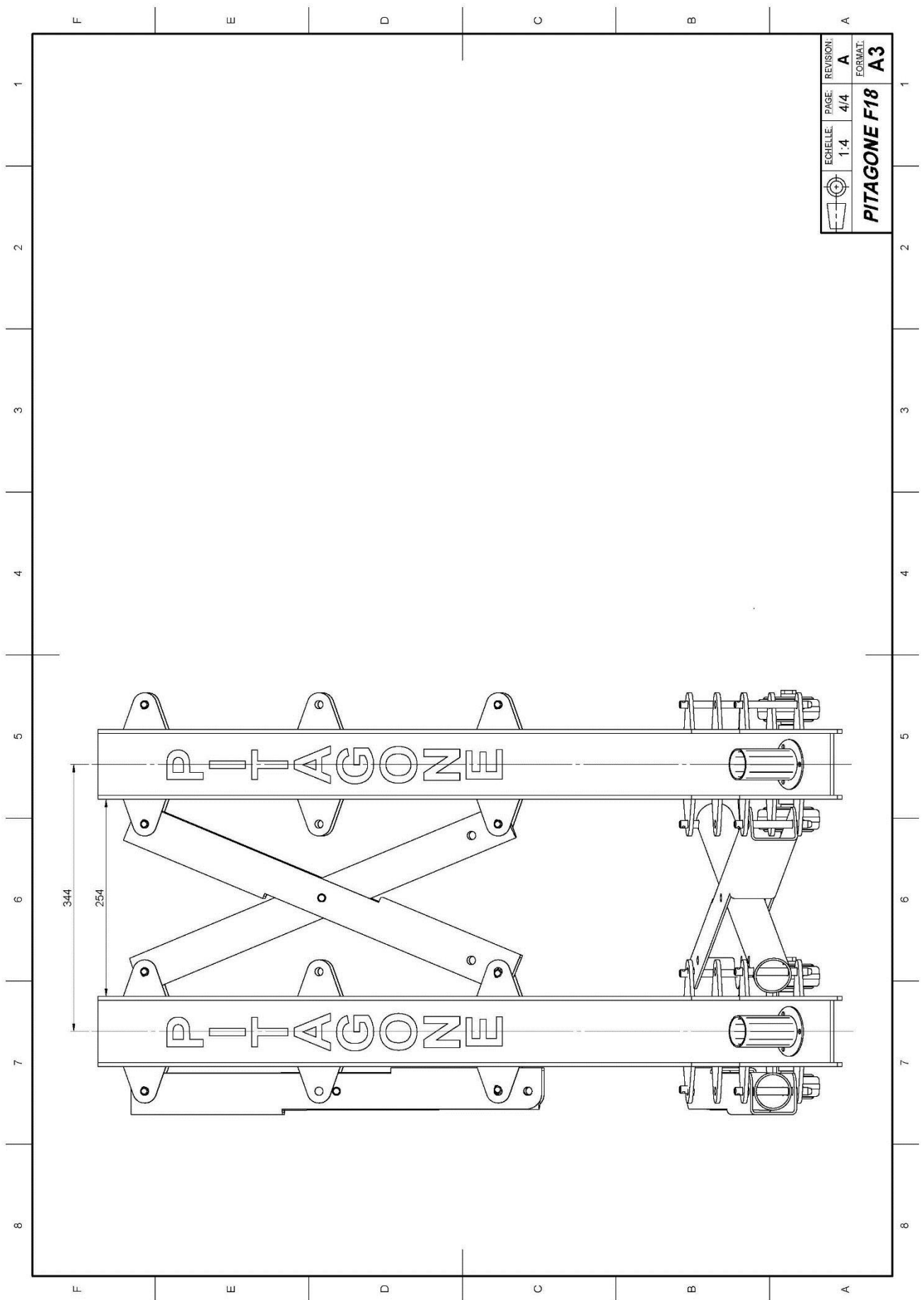

## Appendix 3 Test Vehicle Details

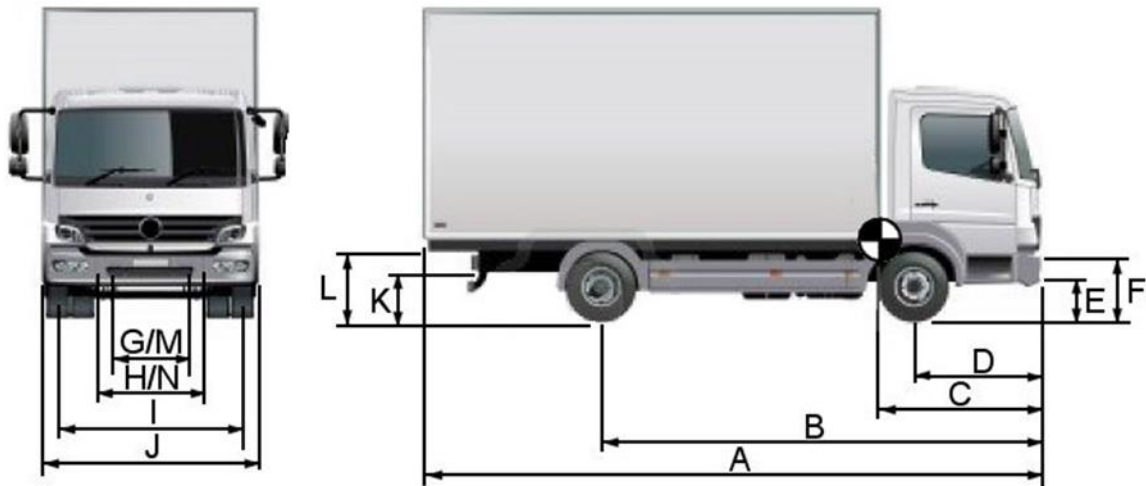

Test Vehicle Details	
Vehicle classification	N3
Vehicle Registration No.	MX09FRO
Vehicle Identity No (VIN)	XLRAE55GFOL352850
Unladen Mass (kg)	6466
Test Inertial Mass (kg)	7508
Net Ballast Mass (kg)	1042
Number of axles x driven axle	2 x 1
Tyre Size	295/80/R22.5

Test Vehicle Measurements					
A	Vehicle Length	9727	H	Distance between outside edges of chassis rail at front	807
B	Vehicle front to rearmost axle	6783	I	Front track width (tyre centres)	2008
C	Vehicle front to datum point	1928	J	Vehicle width	2563
D	Vehicle front to front axle	1378	K	Height from ground level to bottom of chassis rear	795
E	Height from ground level to bottom of chassis front	778	L	Height from ground level to top of chassis rear	1074
F	Height from ground level to top of chassis front	1051	M	Distance between inside edges of chassis rails at rear	640
G	Distance between inside edges of chassis rails at front	635	N	Distance between outside edges of chassis rails at rear	809

## Appendix 4 Calibration Information

### Other Tools

Item	QA No	Used for Measuring	Cal Due Date
Scales (LHF)	32098	Vehicle mass	09/10/2019
Scales (RHF)	32099	Vehicle mass	09/10/2019
Scales (LHR)	32098	Vehicle mass	09/10/2019
Scales (RHR)	32099	Vehicle mass	09/10/2019
Tape Measure	41047	Vehicle	25/01/2020
Inclinometer	39700	General angles	10/03/2020
VBox GPS	36509	Impact Speed and Angle	09/10/2019

### High Speed Cameras

Position	Camera QA No	Cal Due Date	Lens Type	Image rate (pps)	X (m) to impact	Y (m) to impact	Z (m) to impact
OH Standard	41526	23/03/19	12	500	0	0	12.4
OH Close	41527	23/03/19	16	500	0	0	12.4
Side on RH	41524	23/03/19	35	500	0	-30	1.4
Downstream	41528	23/03/19	300	500	76	0	1.4
Oblique	41523	23/03/19	35	500	11	13	1.4

## Appendix 5 Revision History

Report Number	Date	Comments	Sections Affected
1219545-002-01	27/03/2019	First Issue	n/a
PAS68 1219545-002-02	24/04/2019	Updated manufacturer address Updated report number	Section 1.2 Executive summary Throughout